

HEWLETT PACKARD

MODEL 686C
SWEEP OSCILLATOR
SERIALS PREFIXED: 110-

OPERATING AND SERVICING MANUAL



OPERATING AND SERVICING MANUAL



MODEL 686C SWEEP OSCILLATOR SERIALS PREFIXED: 110-



WWW.HPARCHIVE.COM
For Free Distribution Only

Copyright HEWLETT-PACKARD COMPANY 1961
1501 PAGE MILL ROAD, PALO ALTO, CALIFORNIA, U. S. A.

SPECIFICATIONS

FREQUENCY RANGE:	8.2 to 12.4 kmc
SWEEP RANGE:	4.4 mc to 4.4 kmc in 7 steps. Continuous control between steps
RF SWEEP RATE OF CHANGE:	32 mc/sec to 320 kmc sec in 9 steps
SWEEP TIME:	.0139 sec to 139 sec for full band sweep; determined by sweep range and rate
POWER OUTPUT:	Adjustable; 0 to at least 10 mw into matched load (swr - 1.25)
POWER VARIATION:	With leveler operating: less than ± 1.25 db over entire frequency range. With leveler off: less than ± 1.5 db over the entire frequency range
RESIDUAL FM:	Less than 200 kc peak
SPURIOUS SIGNALS:	At least 30 db below cw output
MAXIMUM SWR:	2 or less
SWEEP MODE:	Recurrent; externally triggered (20v positive with better than 3v/usec rate of rise); manually triggered. RF Frequency sweep is linear with respect to time and is downward from frequency dial setting
SWEEP OUTPUT:	Approximately +25v peak sawtooth provided concurrently with swept rf output for recorder and oscilloscope sweep. Source impedance 10K ohms and 20 pf in parallel
SWEEP WIDTH:	Accuracy: $\pm 10\%$ for full band sweep. $+25\%$ -15% or ± 3 mc, whichever is greater for other calibrated sweep widths Linearity: The half-voltage point of the SWEEP OUTPUT occurs with 5% of mid-frequency
FREQUENCY DIAL ACCURACY:	$\pm 1\%$
RESIDUAL AM:	Greater than 40 db below carrier amplitude
MODULATION:	Internal AM: Square-wave modulation continuously adjustable from 400 to 1200 cps. Peak rf output power is within 1 db of the cw level External AM: Direct coupled dc to 300 kc/sec; -20 volts or more reduces rf output level from rated cw output to zero. Input impedance: 750K ohms and approximately 25 pf in parallel External FM: Approximately 150 volts peak-to-peak required to modulate full frequency range. 10 cps to 60 cps. Frequency deviation and modulating voltage must be decreased with modulating frequencies higher than 60 cps. Input impedance: 43K ohms and approximately 100 pf in parallel; ac coupled External Pulse: +10 volts or greater pulse required; 5 millisecond maximum pulse length. Peak rf pulse level within 1 db of cw level. Pulse rise and decay times less than 1 usec. Input impedance: 100K ohms and approximately 45 pf in parallel; ac coupled
POWER:	115/230 volts $\pm 10\%$, 50 to 60 cps, approximately 540 watts
DIMENSIONS:	Cabinet Mount: 20-9/16 in. wide, 12-3/4 in. high, 18 in. deep Rack Mount: 17-5/8 in. wide, 10-1/8 in. high, 16-5/8 in. deep
OUTPUT CONNECTOR:	X-Band Cover Flange (UG-135/U)
WEIGHT:	Cabinet Mount: Net 105 lbs, shipping 134 lbs Rack Mount: Net 105 lbs, shipping 134 lbs

TABLE OF CONTENTS

Section	Page	Section	Page
I GENERAL INFORMATION		III THEORY OF OPERATION (Cont'd)	
1-1. General Information.....	1-1	3-9. Magnet Current Supply (Regulated).	3-11
1-2. Instrument Cooling System.....	1-1	3-10. How a Helix Backward-Wave Tube Works.....	3-11
1-3. Three Conductor Power Cable.....	1-1		
1-4. 230 Volt Operation.....	1-2	IV MAINTENANCE	
1-5. Rack Mounting Instructions.....	1-2	4-1. General.....	4-1
1-6. Backward-Wave Oscillator Tube Information.....	1-2	4-2. General Precautions.....	4-1
		4-3. Air Filter.....	4-2
II OPERATING INSTRUCTIONS		4-4. Cabinet Removal.....	4-2
2-1. Contents.....	2-1	4-5. Maintenance Test Equipment Required	4-2
2-2. Installation.....	2-1	4-6. Quick-Check Procedure.....	4-2
2-3. Turn-On Procedure.....	2-1	4-7. Regulated Magnet Supply.....	4-6
2-4. Using the Sweep Oscillator as a CW Signal Source.....	2-5	4-8. -150 Volt Regulated Supply.....	4-7
2-5. Sweep Operation of the Oscillator..	2-5	4-9. +300 Volt Regulated Supply.....	4-7
2-6. Amplitude Modulating the Oscillator.....	2-5	4-10. Helix Supply.....	4-7
2-7. Frequency Modulating the Oscillator.....	2-5	4-11. Filament Regulation.....	4-9
2-8. Applications.....	2-9	4-12. Measurement of Linear Sweep Times	4-9
		4-13. Replacement of BWO Tube and Calibration Procedure.....	4-10
III THEORY OF OPERATION		4-14. RF Sweep Linearity.....	4-13
3-1. Contents.....	3-1	4-15. Square-Wave Symmetry Adjust. ...	4-15
3-2. Backward-Wave Oscillator Tube...	3-1	4-16. RF Leveler and Reference Anode Voltage Adjustment.....	4-15
3-3. RF Leveler and Reference Anode Circuit.....	3-3	4-17. Servicing the Sweep Circuits.....	4-17
3-4. Amplitude Modulator.....	3-4	4-18. Replacing Neon DC Coupling Elements.....	4-21
3-5. Frequency Modulator.....	3-5	4-19. Positioning the Frequency Dial on the Potentiometer Shaft.....	4-21
3-6. Linear Sweep Generator.....	3-7	4-20. Tube Replacement.....	4-22
3-7. Helix Supply Reference Voltage and Exponential Voltage Generators ...	3-8	V REPLACEABLE PARTS	
3-8. Regulated Power Supplies.....	3-10	5-1. Introduction.....	5-1
		5-2. Ordering Information.....	5-1

LIST OF TABLES

Number	Title	Page
1-1.	Electronic Sweep Oscillators.....	1-1
3-1.	Conditions of Tubes during CW and RF Sweep.....	3-8
4-1.	Tube Replacement Chart.....	4-22
4-2.	Troubleshooting Procedure.....	4-23
5-1.	Replaceable Parts.....	5-1

LIST OF ILLUSTRATIONS

Number	Title	Page	Number	Title	Page
2-1.	Turn-On Procedure and CW Operation	2-2	4-1.	Measuring RF Output	4-3
2-2.	Using the Sweep Oscillator as a Signal Generator	2-3	4-2.	Checking Frequency Calibration and General Performance	4-4
2-3.	Internal Sweep Modulation	2-4	4-3.	Setup for Measuring Residual AM	4-6
2-4.	Internal Square-Wave Modulation	2-5	4-4.	Measuring Magnet Circuit Ripple	4-6
2-5.	External Pulse Modulation	2-6	4-5.	Model 686C Top View	4-8
2-6.	External Amplitude Modulation	2-7	4-6.	Sweep Out Voltage	4-9
2-7.	External Frequency Modulation	2-8	4-7.	Model 686C Bottom View	4-11
2-8.	Allowable External Deviation Limits vs Modulation Voltage Frequency. ...	2-9	4-8.	Model 686C Rear View	4-11
2-9.	Suitable Setup for Measuring Frequency Deviation Limits when using FM	2-9	4-9.	Positioning the BWO Tube at Front and Rear of Magnet.	4-12
2-10.	Input and Output Connector Characteristics	2-10	4-10.	Calibration Pips on CRO Sweep (Linearity)	4-14
3-1.	Backward-Wave Oscillator Tube Construction	3-1	4-11.	Calibration Pips on CRO Sweep (Length)	4-14
3-2.	Block Diagram Model 686C Sweep Oscillator	3-2	4-12.	Crystal Detector-Attenuator Response Curve	4-16
3-3.	Detected Waveform	3-3	4-13.	RF Leveler Circuit Board	4-18
3-4.	Adjustable Segments of Compensated Helix Voltage	3-3	4-14.	RF Leveler Calibration Setup	4-18
3-5.	RF Leveler Circuit	3-4	4-15.	Model 686C Right Side View	4-19
3-6.	Amplitude Modulation EXT. Position .	3-5	4-16.	Model 686C Left Side View.	4-20
3-7.	Frequency Modulator Waveforms	3-6	4-17.	Sweep Out Voltage Linearity	4-21
3-8.	Simplified Schematic of Linear Sweep Generator	3-7	4-18.	Troubleshooting Chart	4-27
3-9.	Simplified Schematic of the Exponential Sweep Generator	3-8	4-19.	Magnet Power Supply (Current Regulated)	4-30
3-10.	Backward-Wave Oscillator Tube	3-12	4-20.	Primary Power and Regulated Magnet Supply	4-31
3-11.	A Single Regenerative Loop	3-12	4-21.	Regulated +300 and -150 Volt Power Supplies	4-32
3-12.	A Chain of Regenerative Loops	3-12	4-22.	Low Voltages and Regulated Helix Supply	4-33
3-13.	Cross Section of Helix Electron Beam and Helix Wave	3-13	4-23.	RF Power Leveler and Amplitude Modulator	4-34
3-14.	Axial Electric Field of Helix Wave which provides Velocity Modulation and Bunching of Electron Beam	3-13	4-24.	Amplitude Modulator and Reference Anode Circuit	4-35
3-15.	Helix Showing Bunching of Electron Beam	3-13	4-25.	Frequency (BWO Helix) Modulator ...	4-36
3-16.	Relative Amplitude of the Helix Wave and the Degree of Electron Bunch- ing along Helix		4-26.	Linear and Exponential Sweep Generator Circuit	4-37

MODEL 686C

ELECTRONIC SWEEP OSCILLATOR

This manual specifically describes 686Cs of the T110 series, and in general describes all 686C Sweep Oscillators. If, however, the serial number of your instrument is prefixed by T024 or T044, there are parts of the manual which do not apply to your instrument. If your instrument carries one of these serial numbers, information specific to your instrument is furnished with this manual. This supplementary material includes schematics, parts list, and replacement paragraphs and illustrations for those items in the manual that do not describe your instrument. The supplementary data is indexed; paragraph and figure numbers are the same as those used in the manual for the corresponding information.

If it is necessary to order a replacement part, consult the supplementary parts list first. If the component is not listed, use the part number given in Section V of the manual; otherwise, always use the part number in your supplementary parts list.



**BACKWARD WAVE OSCILLATOR TUBE WARRANTY CLAIMS AND ADJUSTMENT
PROCEDURE FOR STEWART ENGINEERING COMPANY TUBES SUPPLIED BY
HEWLETT-PACKARD COMPANY**

CONDITIONS OF WARRANTY

A backward wave oscillator tube manufactured by Stewart Engineering Company, Soquel, California, is warranted by the manufacturer to be free of defects in material and workmanship for 18 months from the date of purchase from $\text{\textcircled{hp}}$, or 500 hours filament life, whichever occurs first. Allowances for premature failure within 6 months from the date of shipment from $\text{\textcircled{hp}}$ will be pro-rated on the basis of remaining guaranteed filament life. Following the 6 month period, allowance for premature failure will be pro-rated on the basis of remaining guaranteed filament life, or on the basis of months remaining in this 12 month period, whichever is the lesser credit.

The Hewlett-Packard Company will process warranty claims for $\text{\textcircled{hp}}$ customers on Stewart backward wave oscillator tubes which were supplied by $\text{\textcircled{hp}}$ as original equipment or replacements for $\text{\textcircled{hp}}$ instruments. All allowances by the manufacturer will be passed on to the customer.

After expiration of this warranty, all replacement backward wave oscillator tubes should be obtained directly from Stewart Engineering Company, Soquel, California.

A Stewart backward wave oscillator tube returnable to the Hewlett-Packard Company under the conditions of this warranty must be packed and shipped according to instructions below, and must be accompanied by the Warranty Claim on the reverse side of this form. Any chronistor included in the instrument, must also be returned with the Warranty Claim. Please follow shipping instructions carefully to assure safe arrival of the backward wave oscillator tube since no allowance can be made on broken tubes.

SHIPPING INSTRUCTIONS

- 1) Carefully wrap the backward wave oscillator tube in 1/4 inch thick "kimpack", cotton batting, or other soft padding material.
- 2) Wrap the above in heavy kraft paper.
- 3) Pack in a rigid container which is at least 4 inches larger than the tube in each direction.
- 4) Surround the tube with at least 4 inches of packed excelsior or similar shock absorbing material. Be certain that the packing is tight all around the tube.
- 5) Tubes returned from outside the continental United States should be packed in a wooden box.
- 6) Mark container FRAGILE and ship prepaid via Air Freight or Railway Express. Do not ship via Parcel Post or Air Parcel Post since experience has shown that fragile items are more apt to be damaged when shipped by these means.

3/9/59

BACKWARD WAVE OSCILLATOR TUBE WARRANTY CLAIM

IMPORTANT: -- To expedite your claim, please answer all questions fully since a claim cannot be processed without adequate information.

FROM: _____ DATE: _____
NAME _____
COMPANY _____
ADDRESS _____

Person to contact for further information:
NAME _____
TITLE _____
COMPANY _____
ADDRESS _____

If instrument contains a
chronistor please remove
and attach below

Check if instrument does
not contain chronistor

Tube type _____ Serial No. _____
Tube used in ϕ Model _____ Serial No. _____
Tube is: Original _____ Replacement _____ Date tube received _____
Date tube placed in service _____ Date of tube failure _____
Your Purchase Order No. _____ Purchased from _____
Hours service per day (average) _____ No. of days in service _____
Total filament operation _____ hours

SYMPTOMS: (Please describe nature of trouble) _____

OPERATING CONDITIONS: (Please describe conditions prior to and at time of failure)

SIGNATURE _____

IF TUBE WAS NOT OBTAINED FROM HEWLETT-PACKARD COMPANY, PLEASE RETURN
TUBE AND COMPLETED FORM TO WHEREVER TUBE WAS PURCHASED.

SECTION I

GENERAL INFORMATION

1-1. GENERAL DESCRIPTION.

The $\text{\textcircled{hp}}$ Model 686C Sweep Oscillator is one of several $\text{\textcircled{hp}}$ Electronic Sweep Oscillators which together cover major microwave bands as shown in Table 1-1.

Table 1-1. Electronic Sweep Oscillators

$\text{\textcircled{hp}}$ Model	Frequency Range
682C	1.0 to 2.0 kmc
683C	2.0 to 4.0 kmc
684C	4.0 to 8.1 kmc
H01 686C	7.0 to 11.0 kmc
686C	8.2 to 12.4 kmc
687C	12.4 to 18.0 kmc

Sweep oscillators are used as signal sources for a wide variety of laboratory and production tests. They provide a high level constant amplitude signal that can be rapidly changed in frequency. Thus they permit microwave characteristics of systems or components to be quickly checked over an entire band of frequencies.

The $\text{\textcircled{hp}}$ Model 686C Sweep Oscillator is a refined instrument of this general type. It covers the complete X band from 8.2 to 12.4 kmc and uses a Backward-Wave Oscillator (bwo) tube to generate the rf signal.

The bwo tube has several advantages over the previously used klystron-type microwave oscillator tubes when used in sweep-type oscillators:

The bwo tube output frequency and power level are determined by the value of the applied voltages only. There are no cavity or repeller voltages to adjust or track. There is no tendency to switch modes of oscillation. Since frequency and power level adjustments are electronic, all mechanical problems associated with tunable cavity klystron-type oscillators are eliminated. Control of frequency and power level is simple, positive and straightforward. By use of an rf leveler circuit, which programs the rf power output from the bwo, output power variations of ± 1.25 db or less are realized. With the rf leveler inoperative, output power from the bwo is constant to within ± 1.5 db, but full power from the bwo tube is obtained. The rf output power is continuously adjustable from 0 to maximum, which is not less than 10 milliwatts into a matched waveguide load.

The Model 686C Sweep Oscillator is versatile. The output can be cw, externally amplitude-modulated at any percentage from 0 to 100%, externally pulse-modulated, or externally square-wave modulated. An internal square-wave source provides square-wave modulation at any frequency between 400 and 1200 cps. The oscillator can be frequency-modulated or swept in frequency over any portion or all of the X band range of 8.2 to 12.4 kmc.

When used for its primary purpose as a sweep oscillator, the internal circuitry provides an extremely wide choice of sweeping rates and band width swept. The rate of change of frequency is linear with time and adjustable in calibrated steps from 32 mc/sec to 320 kmc/sec. The frequency range swept can be as small as 4.4 mc or the full range of 4.4 kmc, as selected by a calibrated seven position Δ FREQUENCY switch. In addition, there is a VERNIER control associated with the Δ FREQUENCY switch which gives continuous adjustment between the fixed positions.

The minimum sweep time of the Model 686C is approximately 14 milliseconds. The sweep time is determined by the combined setting of the RF SWEEP RATE and the Δ FREQUENCY switches. These switches are interlocked by a differential gear drive which automatically prevents any combination which would produce a sweep time less than 14 milliseconds.

The swept rf output from the oscillator is linear with time, and a 20-25 volts sawtooth voltage is provided concurrent with each rf sweep to supply a linear time base for an oscilloscope or X-Y recorder. The oscillator sweep can be made recurring, or set for single sweeps. Single sweeps can be started either by the front-panel push button or by an external positive pulse (rise time greater than 3 volts per microsecond).

1-2. INSTRUMENT COOLING SYSTEM.

The instrument is forced-air cooled by a high velocity fan system. The incoming air is filtered to remove excessive dust. This filter must be inspected frequently to insure that it is not clogged with dirt. A dirty filter may restrict air flow sufficiently to cause excessive heating of the instrument which can cause early component failure (see paragraph 4-3).

1-3. THREE CONDUCTOR POWER CABLE

To protect operating personnel, the National Electrical Manufacturer's Association (NEMA) recommends that the instrument panel and cabinet be grounded. All $\text{\textcircled{hp}}$ instruments are equipped with a three-conductor power cable which, when plugged into an appropriate receptacle, grounds the instrument. The offset pin on the power cable three-prong connector is the ground pin.

To preserve the protection feature when operating this instrument from a two-contact outlet, use a three-prong to two-prong adapter and connect the green pigtail on the adapter to ground.

The magnet power supply is isolated from the chassis, and the polarity of the primary power wiring has been carefully controlled to insure that internal exposed parts and wiring are generally at ground potential.

When the instrument is connected to a properly wired power system this polarity will be maintained as intended. If the instrument is operated from a two terminal receptacle, the identification of the grounded power conductor is lost. The proper grounding of the instrument cabinet thus becomes important as a matter of good safety practice.

1-4. 230 VOLT OPERATION.

The Model 686C is usually shipped wired for 115 volts ac operation, but is quickly and easily converted to operation from a nominal 230 volt 50/60 cps source. To convert, remove two jumper wires between A1-A3 and A2-A4 on the power transformer (T1) and install one jumper between terminals A2 and A3. In addition, remove the jumper wire from the rear terminal of the HIGH-VOLTAGE (H.V.) fuse and reconnect to the side terminal of the H.V. fuse. This side terminal also has a pink lead attached to it.

Do not change the size of either the MAGNET fuse or the H.V. fuse. When operating from a 230 volt source, the MAGNET supply and the fan operate on 115 volts supplied by T1 primary windings which act as a 2:1 auto-transformer. This additional load is added to the normal load carried by the H.V. fuse and approximately offsets the expected reduction in current due to 230 volt operation.

1-5. RACK MOUNTING INSTRUCTIONS.

When mounting a rack model instrument, leave at least 3 inches clearance behind the air intake to insure proper air circulation. In addition, be certain that the air intake is not near another piece of equipment which is discharging hot air in the vicinity of the Model 686C air intake.

The following instructions should be followed for easy installation of a rack model instrument (686CR) in an equipment rack.

- 1) Remove the four (4) screws from the rear of the instrument cabinet and slide the instrument forward from the cabinet.
- 2) Mount the empty cabinet in the equipment rack with four (4) oval head machine screws: two screws on each side of the cabinet in the mounting holes approximately 1-3/4 inches from the top and bottom edge of the mounting flanges.
- 3) Raise the instrument chassis and slide gently into the cabinet. Be certain the power cable passes freely through the hole in the rear of the cabinet.
- 4) Fasten the instrument panel securely to the rack.
- 5) Replace the four (4) screws at the rear of the cabinet (if desired).

NOTE

This instrument weighs over 100 pounds. If the rack installation is subject to vibration or rough handling, additional means of support should be provided at the rear of the instrument.

1-6. BACKWARD-WAVE OSCILLATOR TUBE INFORMATION.

The two tube used in this instrument is very expensive and has a shorter guaranteed life than conventional tubes. It is suggested that the instrument be turned off when not being used to increase the useful number of hours service obtained from each tube.

SECTION II

OPERATING INSTRUCTIONS

2-1. CONTENTS.

Section II contains instructions for setting up and operating the sweep oscillator, instructions for modulating the rf output and a discussion of some applications of the instrument.

2-2. INSTALLATION.

The Model 686C Sweep Oscillator should be placed on a work bench or table with at least 3 inches of clearance at the rear to insure adequate air flow through the air filter. To avoid seriously restricted air flow, be careful not to let loose pieces of paper, etc., remain in the rear area, since they can be pulled against the air filter.

The power cable should be used in a NEMA approved standard three-prong grounding receptacle (paragraph 1-3).

Complete installation instructions for rack model instruments are given in paragraph 1-5.

2-3. TURN-ON PROCEDURE.

Good operating practice insists that you follow a step by step procedure when turning on the Model 686C to protect the bwo tube. This routine will systematically check out proper operation of all critical circuits to insure normal operation. Under normal instrument operation no damage can be done by improper setting of front panel controls, since built-in overload protection has been provided which will cut off primary power to the high voltage transformer if excessive current flows in the helix circuit. The overload circuits are reset by momentarily turning off power to the instrument. In addition, internal screwdriver-adjust controls preset limits on front panel controls to safe values. Bwo tube currents are monitored with the built-in metering circuits, which provide a positive check that the bwo tube is being operated in a safe manner.

To place the instrument in operation, the 16 steps outlined in figure 2-1 should be followed in the order given. Additional data on some of the steps are given below under STEPS; before performing the turn-on procedure for the first time, read this supplemental information.

When the turn-on procedure is followed as given below, the instrument will be set up for cw operation. Once this operation has been established, the power level can be properly set, and the oscillator adjusted for any other mode of operation; the rf level and frequency will be accurately known.

STEPS:

1. Rotate CATHODE CURRENT control full counter-clockwise (minimum position).

2. Rotate CURRENT switch to MAGNET.
3. Rotate AMPL. MOD. SELECTOR switch to OFF.
4. Rotate SWEEP SELECTOR switch to OFF.
5. Set POWER switch to ON. The plastic graticule at the top of the FREQUENCY dial will glow. The cooling fan will operate. A thermal time-delay relay delays application of high voltage to the main circuits approximately 60 seconds after the instrument is energized. The magnet supply circuits are partially energized when the POWER switch is turned ON, but do not regulate until the time delay has operated and the filaments in the regulator circuits are energized.
6. Read the magnet current on monitor meter. The current should be 0.5 to 0.65 ampere when first turned on and will settle at 0.70 ampere after complete warmup (1 hour). DO NOT OPERATE INSTRUMENT AFTER WARMUP UNLESS THE MAGNET CURRENT IS BETWEEN 0.675 and 0.725 AMPERE (see paragraph 4-21).
7. Rotate the CURRENT switch to CATH.
8. Set RF LEVELER switch to ON.
9. It is important that the meter reads the exact cathode current at the frequency indicated on the meter plate. The reasons are: a) Only with rated cathode current at the frequency specified, will adequate power be produced. b) The RF LEVELER will not give the desired leveling action (± 1.25 db) if the latter conditions are not met.
10. Rotate CATHODE CURRENT control clockwise and observe current reading. Normal output (at least 10 milliwatts) will be obtained with cathode current value and frequency stamped on panel meter. (The maximum current is limited by internal adjustments.)
11. Rotate CURRENT switch to HELIX.
12. Read the helix current. The current must be less than 3 ma. Excessive helix current indicates misalignment of the bwo tube in the magnetic field. (See paragraph 4-13.)
13. Rotate CURRENT switch to ANODE.
14. The anode current will read about 0.2 ma and should not exceed 0.5 ma.
15. Rotate CURRENT switch to COL.

Verify proper operation of the helix voltage supply by rotating the FREQUENCY dial from 12.4 to 8.2 kmc and noting a large variation in helix current.

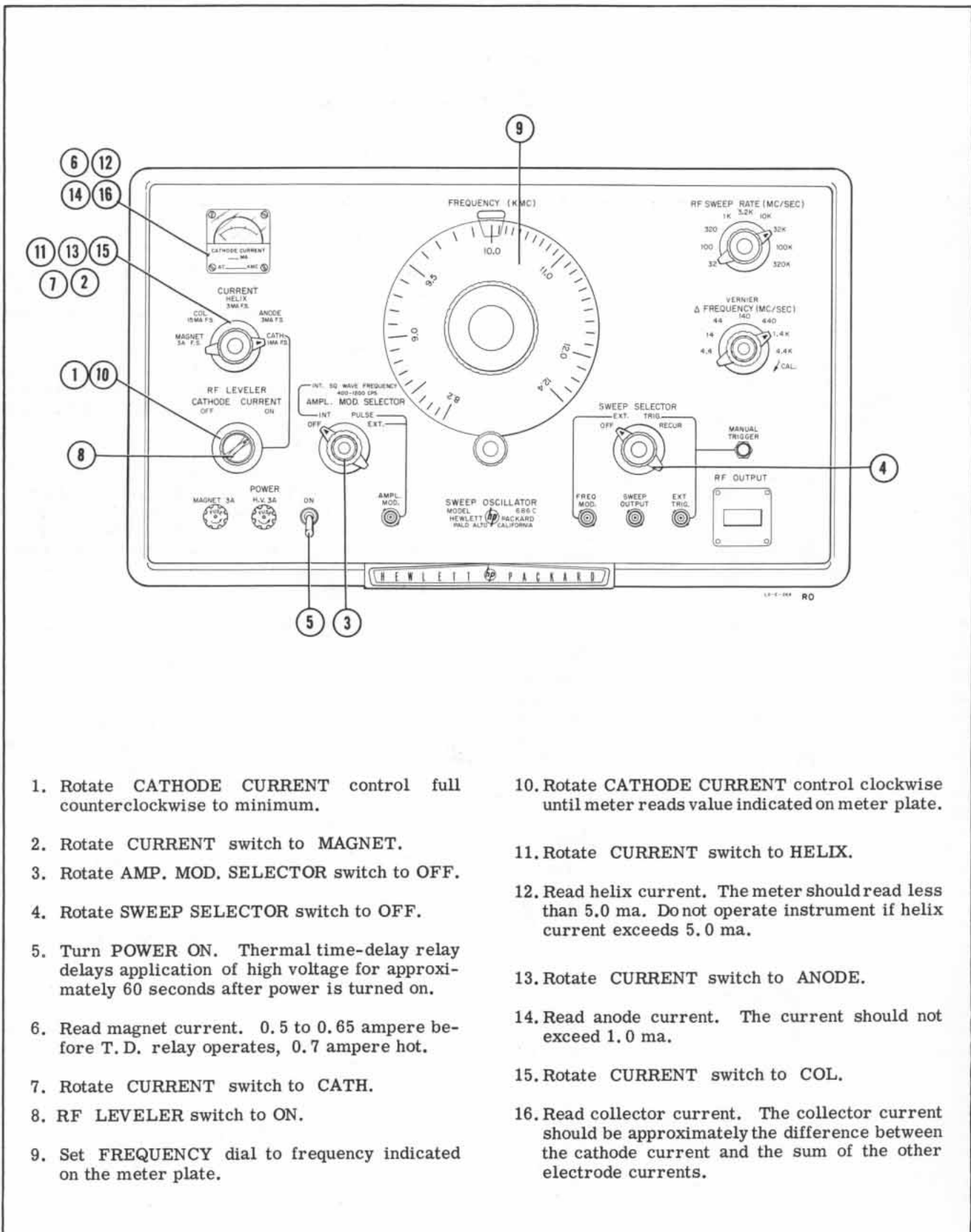

1. Rotate CATHODE CURRENT control full counterclockwise to minimum.
2. Rotate CURRENT switch to MAGNET.
3. Rotate AMP. MOD. SELECTOR switch to OFF.
4. Rotate SWEEP SELECTOR switch to OFF.
5. Turn POWER ON. Thermal time-delay relay delays application of high voltage for approximately 60 seconds after power is turned on.
6. Read magnet current. 0.5 to 0.65 ampere before T. D. relay operates, 0.7 ampere hot.
7. Rotate CURRENT switch to CATH.
8. RF LEVELER switch to ON.
9. Set FREQUENCY dial to frequency indicated on the meter plate.

10. Rotate CATHODE CURRENT control clockwise until meter reads value indicated on meter plate.
11. Rotate CURRENT switch to HELIX.
12. Read helix current. The meter should read less than 5.0 ma. Do not operate instrument if helix current exceeds 5.0 ma.
13. Rotate CURRENT switch to ANODE.
14. Read anode current. The current should not exceed 1.0 ma.
15. Rotate CURRENT switch to COL.
16. Read collector current. The collector current should be approximately the difference between the cathode current and the sum of the other electrode currents.

Figure 2-1. Turn-On Procedure and CW Operation

16. The collector current should read 2 to 3 ma. The collector current is the difference between the cathode current and the sum of the other electrode currents.

The instrument is now operating normally and generating a 10 milliwatt or more CW signal at the frequency indicated by the FREQUENCY dial.

2-4. USING THE SWEEP OSCILLATOR AS A CW SIGNAL SOURCE.

Upon completion of the procedure above, the instrument is set up for cw operation. However, check that the AMPL. MOD. SELECTOR switch and the SWEEP SELECTOR switch are to OFF; the RF LEVELER switch to ON.

The output frequency is indicated by the FREQUENCY dial to an accuracy of better than 1%. The output power level is adjustable from at least 10 milliwatts down to zero by the CATHODE CURRENT control.

By the addition of a precision attenuator and power monitoring provisions, the 686C can be used as a signal generator. Figure 2-2 shows such a set-up. With one precision attenuator signal levels of -60 dbm can be obtained. If lower levels are needed, a second precision attenuator can be added to accurately reduce levels below -100 dbm. The rated accuracies of the individual components are given.

2-5. SWEEP OPERATION OF THE OSCILLATOR.

After the oscillator has been set up for cw operation, the power level should be set to the desired level and the FREQUENCY dial set to the proper setting. The rf sweep is downward from the frequency indicated on the dial. (See figure 2-3, Internal Sweep Operation.)

2-6. AMPLITUDE MODULATING THE OSCILLATOR.

Set up the oscillator for cw operation as shown in figure 2-1. After adjusting the rf output level with the CATHODE CURRENT control, set the AMPL. MOD. SELECTOR for the type of operation desired. Operation at various positions of the switch are described in figures 2-4, 2-5, and 2-6.

2-7. FREQUENCY MODULATING THE OSCILLATOR. (See figure 2-7)

The oscillator can be externally sweep modulated by placing the SWEEP SELECTOR switch in the EXT. position and applying the modulating voltage to the FREQ. MOD. jack.

The frequency modulation is up and down from the frequency indicated on the FREQUENCY dial. Positive going voltage applied to the FREQ. MOD. jack increases the frequency.

The full frequency band may be swept at a rate of 10 cps to 60 cps by using a voltage approximately 150 volts peak-to-peak. Above 60 cps, the band swept must be reduced to avoid overload of the power supplies. Figure 2-8 is a chart showing the limits of allowable frequency deviation as the modulating frequency is increased above 60 cps.

Consideration must be given to the modulation characteristics of the bwo. A linear change in modulation voltage produces an exponential change in rf output. The sensitivity at the FREQ. MOD. jack varies from approximately 19.2 mc/volt at 12.4 kmc to approximately 37.6 mc/volt at 8.2 kmc. For small frequency deviations, the sensitivity vs. frequency curve can be considered a straight line.

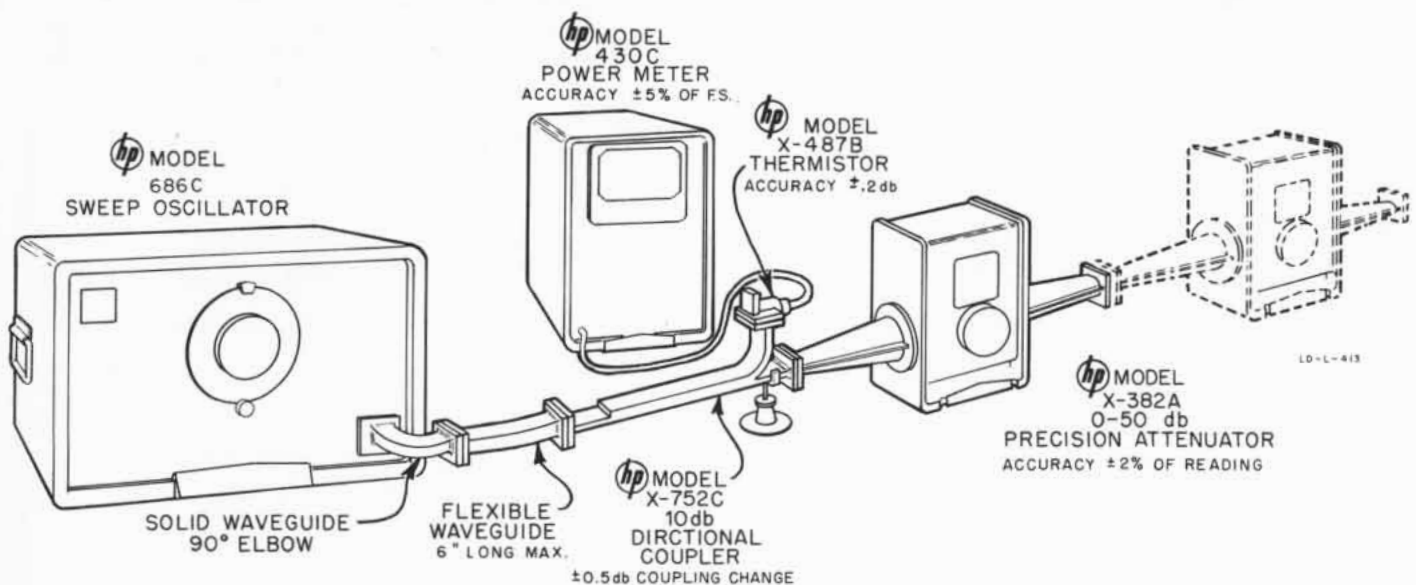
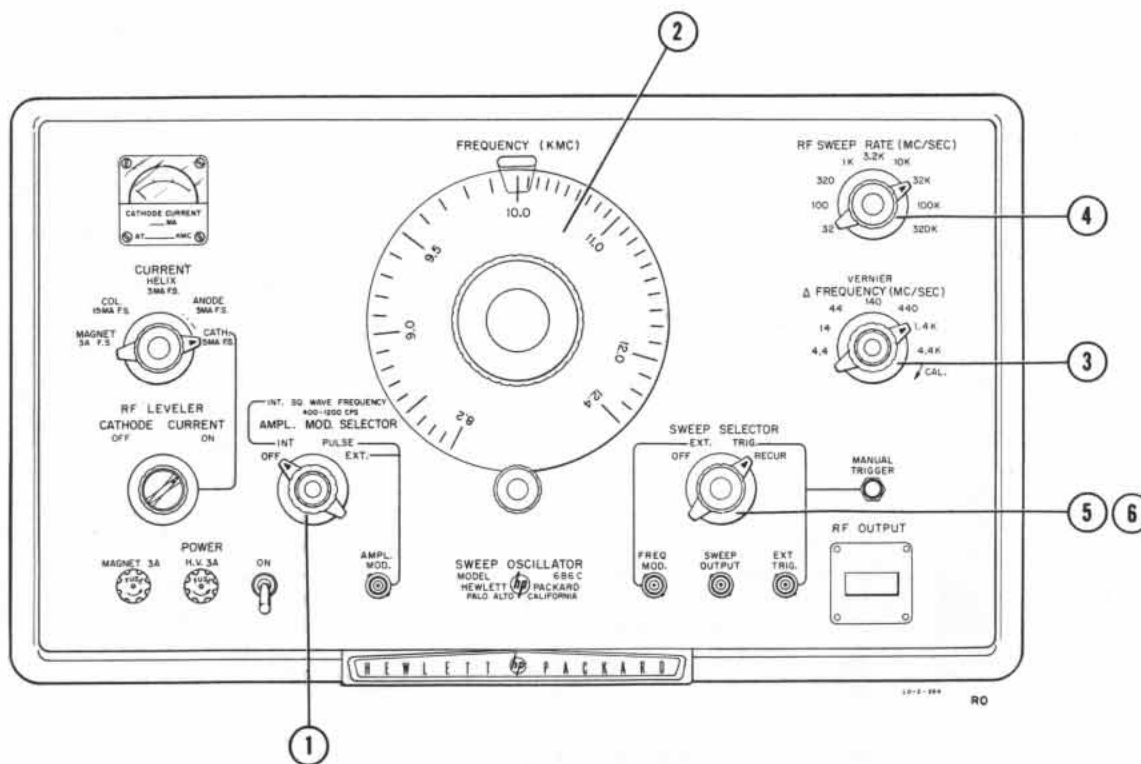

Figure 2-2. Using the Sweep Oscillator as a Signal Generator



First turn on instrument and adjust for normal output under cw operation as shown in the turn-on procedure (figure 2-1).

1. Rotate the AMPL. MOD. SELECTOR switch to OFF, or other desired mode.
2. Set FREQUENCY (KMC) dial to 12.4 kmc (sweep is downward from FREQUENCY dial setting).
3. Rotate Δ FREQUENCY switch to position corresponding to number of megacycles to be swept. Set vernier to CAL. Rotate out of CAL. for variable segments of Δ FREQUENCY.
4. Rotate the RF SWEEP RATE switch to the position corresponding to the rate of sweep desired in mc/sec.

The Δ FREQUENCY switch and the RF SWEEP RATE switch are mechanically interlocked to prevent a combination of settings that would result in a sweep time of less than 0.0139 second.

5. Rotate SWEEP SELECTOR switch to RECUR if automatically recurring sweeps are desired.

6. Rotate SWEEP SELECTOR switch to TRIG. if single sweeps are desired. Sweep may be started by momentarily pressing MANUAL TRIGGER button, or by supplying a positive 20-volt pulse to EXT. TRIG. jack.

CHARACTERISTICS -

Direction:

RF sweeps are downward, starting at the frequency indicated on the FREQUENCY (KMC) dial.

SWEEP OUTPUT voltage is a positive-going 20-25 volt sawtooth voltage.

Accuracy:

Frequency band swept is within $\pm 10\%$ at 4.1 kmc; is within $+25\%$ -15% or ± 3 mc, whichever is greater, for sweep widths less than full band.

Figure 2-3. Internal Sweep Modulation

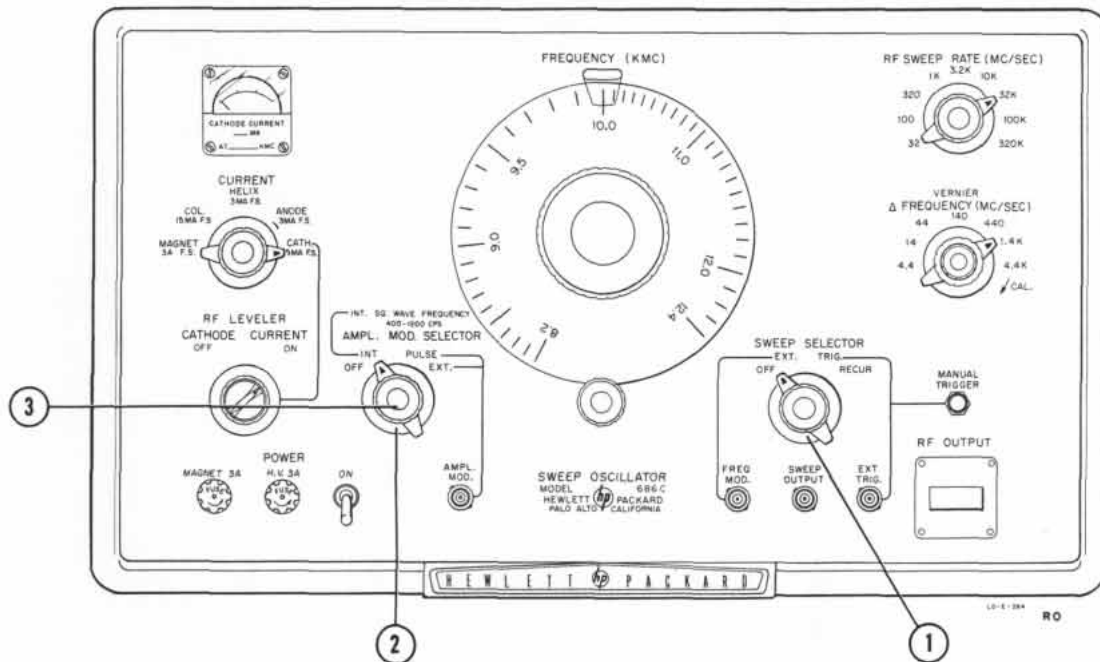

First turn on instrument and adjust for normal output under cw operation as shown in the turn-on procedure (figure 2-1).

1. Rotate SWEEP SELECTOR switch to OFF.
2. Rotate AMPL. MOD. SELECTOR switch to INT.
3. Adjust INT. SQ. WAVE FREQUENCY with red concentric knob.

CHARACTERISTICS -

Range:
400 to 1200 cps.

Symmetry:

Better than 40% - 60%.

Rise and Decay Time:

Less than 2 microseconds.

RF Output:

During "on" time, rf output is within 1 db of established cw level. During "off" time rf output is zero. Rf output frequency is within 4 mc of the cw frequency.

NOTE: The AMPL. MOD. SELECTOR and SWEEP SELECTOR switches operate independently. Both may be set in any position at any time. Thus amplitude and frequency modulation may be obtained simultaneously.

Figure 2-4. Internal Square-Wave Modulation

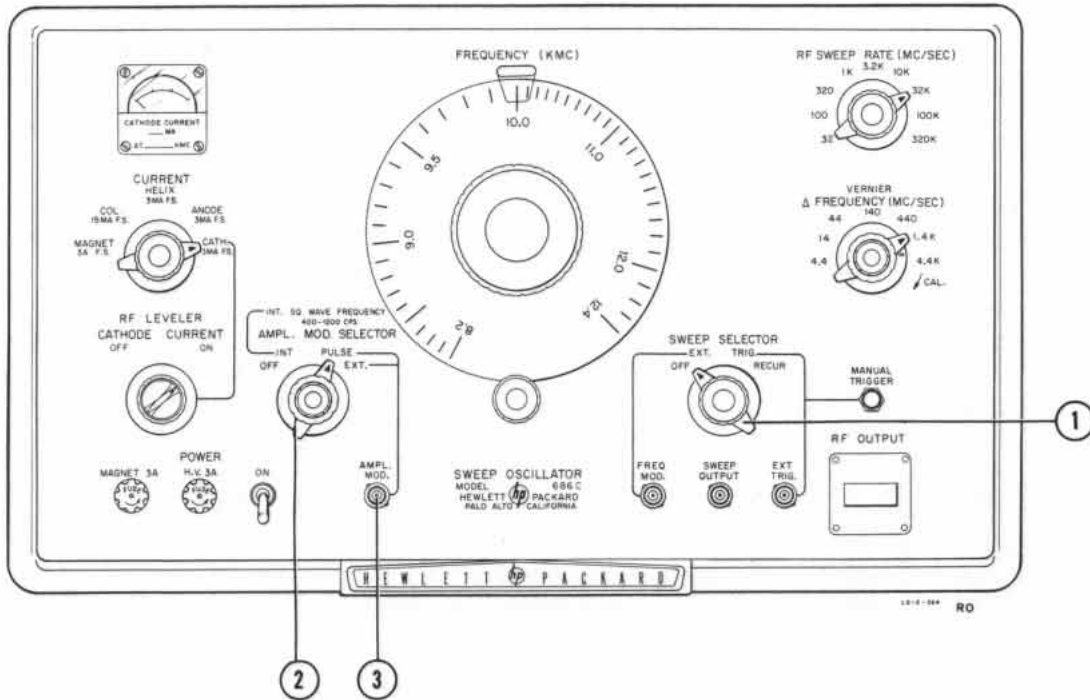

First turn on instrument and adjust for normal output under cw operation as shown in the turn-on procedure (figure 2-1).

1. Rotate SWEEP SELECTOR switch to OFF.
2. Rotate AMPL. MOD. SELECTOR switch to PULSE.
3. a) Feed a +10 to 30 volt signal, 5 milliseconds or less in width, at frequencies from 100 cps to 300 kc into the AMPL. MOD. jack.
b) A square wave, -10 volts or more can also be applied to the AMPL. MOD. jack.

CHARACTERISTICS -

RF Output:

During "on" time, rf output is within 1 db of established cw level. During "off" time, rf output is zero. Rf output frequency is within 4 mc of the cw frequency.

NOTE: The AMPL. MOD. SELECTOR and SWEEP SELECTOR switches operate independently. Both may be set in any position at any time. Thus amplitude and frequency modulation may be obtained simultaneously.

Figure 2-5. External Pulse Modulation

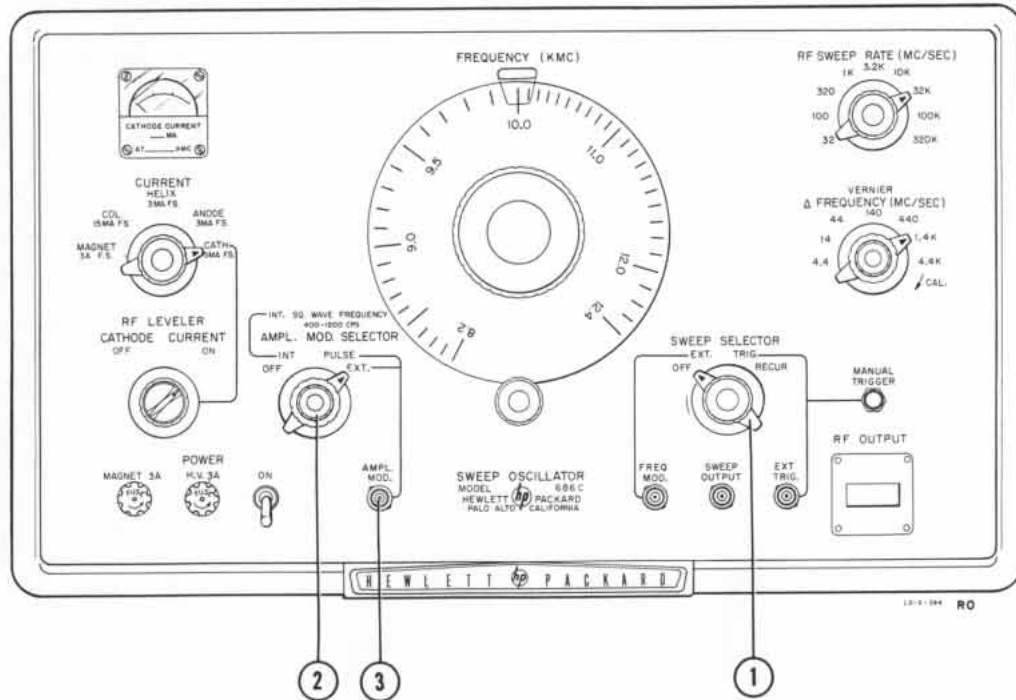

First turn on instrument and adjust for normal output under cw operation as shown in the turn-on procedure (figure 2-1).

1. Rotate SWEEP SELECTOR switch to OFF.
2. Rotate AMPL. MOD. SELECTOR switch to EXT.
3. Feed modulation voltage of -20 volts or less from an external source into AMPL. MOD. jack.

NOTE: Positive input pulse can be applied providing it is either capacitively coupled or superimposed on an externally supplied -20 volt bias. If capacitively coupled the capacitor must be sufficiently large and the duty cycle such as to maintain a charge (grid bias) between modulation pulses. However, if the signal

source has a large internal capacitor in series with the output, (example  Model 212A) no external capacitor is needed.

CHARACTERISTICS -

Modulation: Direct coupled, dc to 300 kc.

- 1) A modulation voltage of -20 volts applied to the AMPL. MOD. jack.
- 2) A +20 volt signal is applied to the AMPL. MOD. jack, providing a -20 volt bias is applied externally.

Automatic Gain Control:

Since the EXT. position is dc coupled, it applies itself very well to external automatic gain control.

Figure 2-6. External Amplitude Modulation

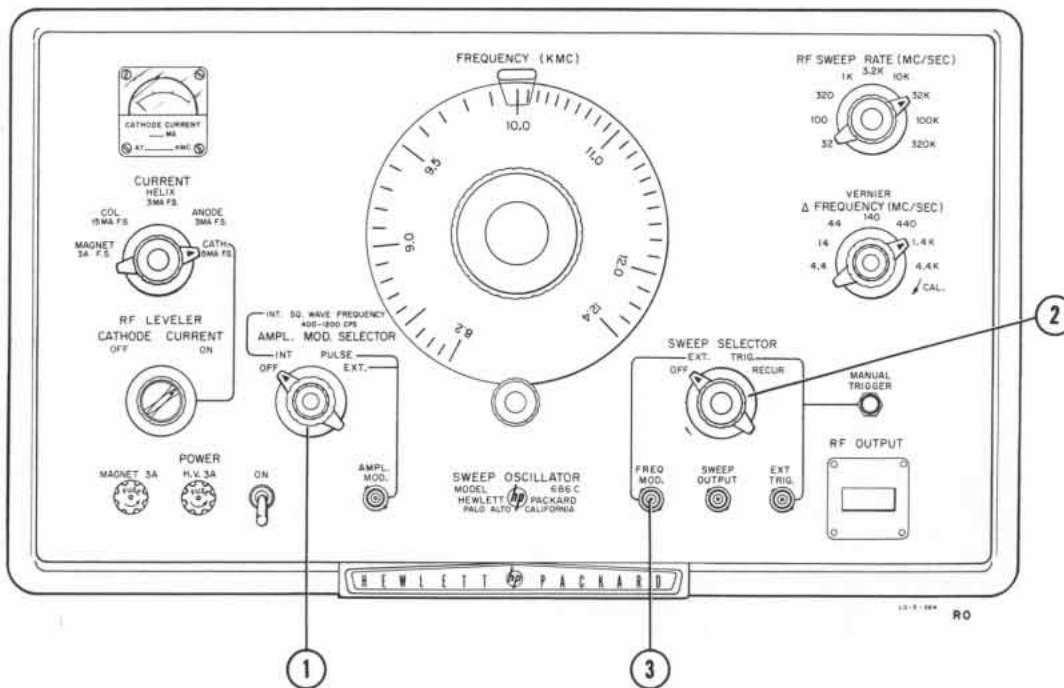

First turn on instrument and adjust for normal output under cw operation as shown in the turn-on procedure (figure 2-1).

1. Rotate the AMPL. MOD. SELECTOR to OFF.
2. Rotate SWEEP SELECTOR switch to EXT.
3. Feed a signal from an external source into the FREQUENCY MOD. jack.

NOTE: Refer to chart figure 2-8 for upper limit on amplitude of modulating frequencies higher than 60 cps. As frequency of modulating frequency increases the band swept must be reduced.

CHARACTERISTICS -

Modulation:

A linear change in modulation voltage produces an exponential change in rf output frequency. Modulation is up and down from the FREQUENCY (KMC) dial setting.

Phase:

Positive-going voltage causes the frequency to increase.

NOTE: The AMP. MOD. SELECTOR and SWEEP SELECTOR switches operate independently. Both may be set in any position at any time. Thus two types of modulation may be obtained simultaneously.

Figure 2-7. External Frequency Modulation

CAUTION

Do not allow the 686C to sweep out of its normal frequency band (8.2 - 12.4 kmc). This can easily occur if relatively modest deviations are being obtained but the frequency dial is set near one band edge.

To guard against this, the output frequency should be observed on an oscilloscope connected to a detector and wavemeter system, such as shown in figure 2-9. The modulating voltage should be applied to the horizontal input. By tuning the wavemeter to the band edge, a notch will be seen in the oscilloscope response and the frequency excursion limits can be accurately determined.

2-8. APPLICATIONS.

One of the valuable uses of a microwave sweep oscillator is its ability to permit rapid measurements of microwave device performance over a full range of frequencies. An example is the rapid measurement of reflection coefficients, attenuation and directivity. The radio meter system is also good for measuring the magnitude of scattering matrix coefficients when it is desired that a transmission-line network be described in terms of such coefficients.

For more detailed information, refer to the *hp* Journal of Sept. -Oct., 1957 (Vol. 9, No. 1-2), which provides

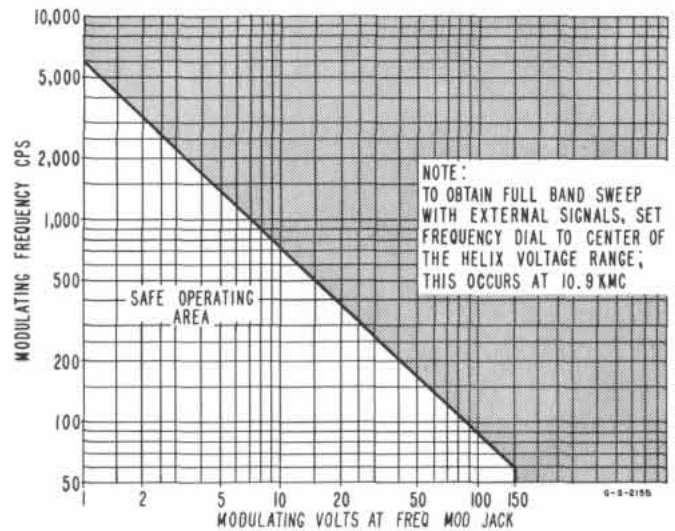

Figure 2-8. Allowable External Deviation Limits vs Modulation Voltage Frequency

practical information about using the sweep oscillator. Several measurement setups are shown, together with recordings and/or oscillograms. The systems described in the article are for making X band measurements. Also, refer to Application Note 42 (Application of the 416A Ratiometer), which gives application of general reflectometer techniques, and to the Journal of Dec. 1960 (Vol. 12, No. 4).

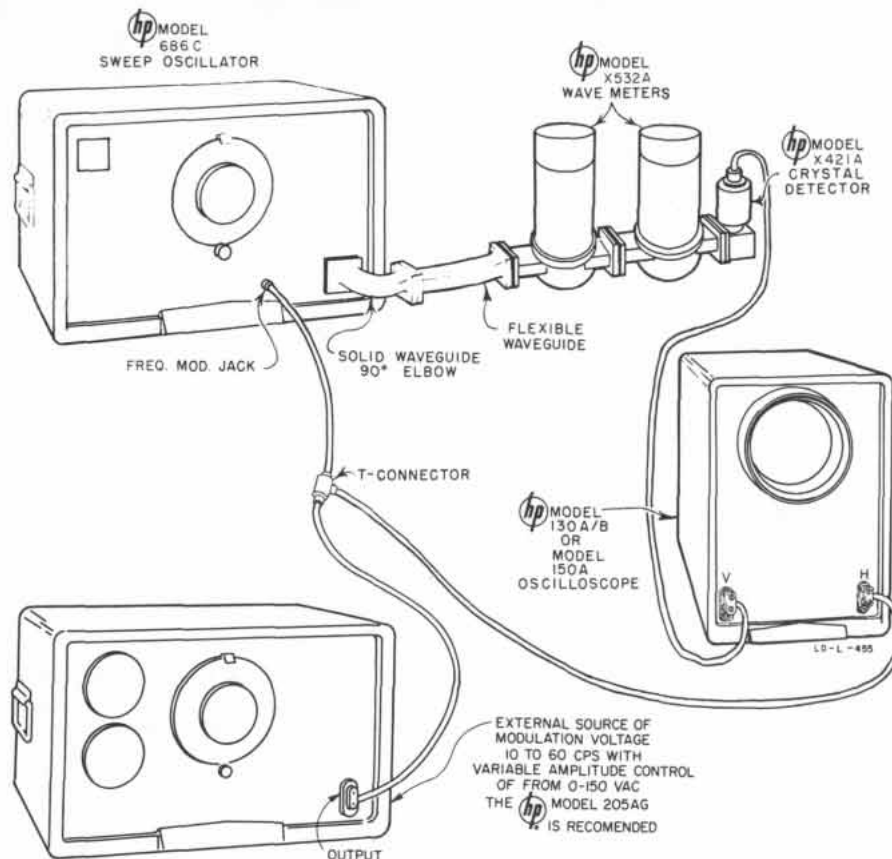
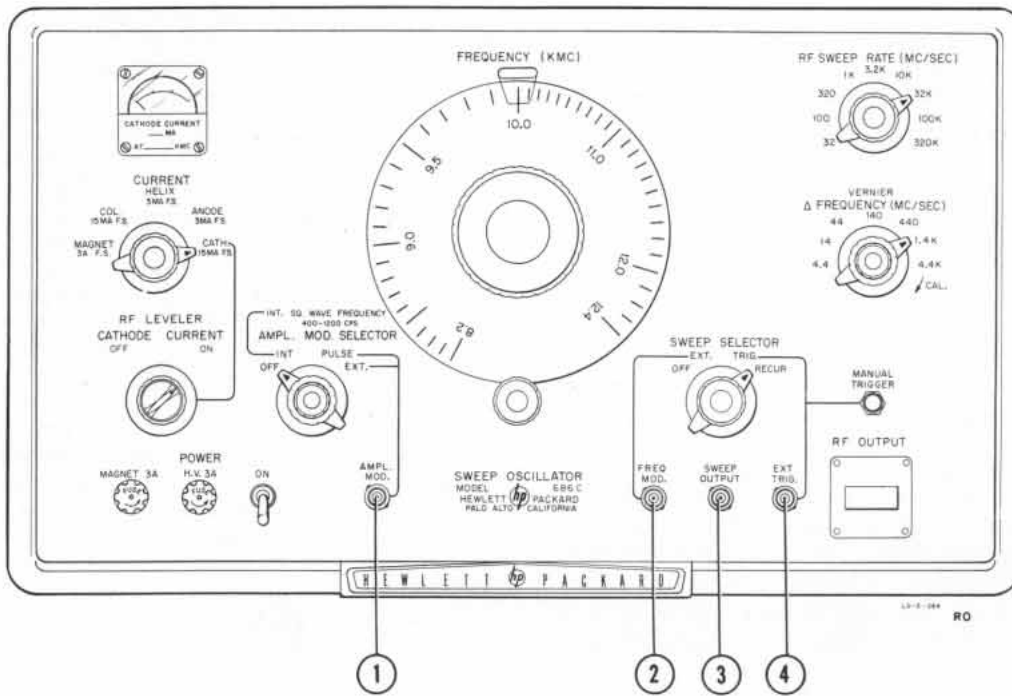

Figure 2-9. Suitable Setup for Measuring Frequency Deviation Limits when using FM



1. PULSE

Input to AMPL. MOD. jack is ac coupled. Input Pulse: +10 volts or more; 5 milliseconds maximum length.
Impedance: 390K shunted by 25 pf.

EXT.

Input to AMPL. MOD. jack: dc to 300 kc; -20 volts or more reduces rf level from cw level to zero.
Impedance: 750K shunted by 25 pf.

2. FREQ. MOD.

Input Impedance: ac coupled; 43K shunted by approximately 100 pf.
Frequency Response: Full band may be swept

10 cps to 60 cps, input voltage must be reduced to avoid overload of power supplies. Refer to chart figure 2-8 for limits at higher modulating frequencies.

Sensitivity: 19.2 mc/volt at 12.4 kmc and 37.6 mc/volt at 8.2 kmc.

3. SWEEP OUTPUT

Output: 20 volts positive-slope sawtooth, concurrent with rf output.
Source Impedance: 10K shunted by 20 pf.

4. EXT. TRIG.

Input: Positive pulse, 20 volts or more, rise time greater than 3 volts/usec.
Impedance: 100K shunted by 10 pf.

Figure 2-10. Input and Output Connector Characteristics

SECTION III THEORY OF OPERATION

3-1. CONTENTS.

This section explains how the circuits of the Sweep Oscillator operate. First, the overall operation of the backward-wave oscillator tube is described. Since the bwo tube is the heart of the instrument, once the characteristics of the tube are understood, an overall picture of the purpose of the various circuits is more easily understood.

For those who want to know in greater detail the method and principles of bwo tube operation, an additional explanation which goes into considerable detail is included at the rear of Section III.

3-2. BACKWARD-WAVE OSCILLATOR TUBE.

The helix type backward wave oscillator tube used in the Sweep Oscillator is similar in appearance to the helix type traveling wave tube (see figure 3-1). Each basically consists of an electron gun, a metallic helix through which the electron beam passes axially, and a collector electrode. The electron gun assembly in a bwo tube produces a hollow electron beam. An external solenoid is used to produce a strong, uniform axial magnetic field around the bwo tube. This magnetic field focuses the electron beam into a hollow cylinder which is concentric with the helix. The tube is accurately positioned in the magnetic field so that the electron

beam passes down the full length of the tube to the collector without striking the helix. Briefly, the tube oscillates as follows:

Rf energy travels down the helix away from the collector end at a velocity equal to the speed of light multiplied by the ratio of the turn-to-turn spacing of the helix divided by the circumference of the helix. This energy causes electric fields to exist along the helix. Since the helix is quite long, a number of rf cycles will exist along its length which speed up and slow down the electron beam, causing it to bunch. The velocity of the electron beam is slightly faster than the effective phase velocity of the rf energy along the helix. When oscillations are taking place, the bunched electron beam advances a quarter of a cycle as it approaches the collector end of the tube, and thus encounters the full decelerating effect of the electric field. This results in the electron beam giving up a maximum amount of kinetic energy to the backward traveling rf wave on the helix.

A more detailed explanation of how a bwo tube operates is given in paragraph 3-10.

A. OUTPUT FREQUENCY

The operating frequency of the bwo is controlled by changing the helix voltage over a range of 400 to 2,000 volts positive with respect to the cathode. The

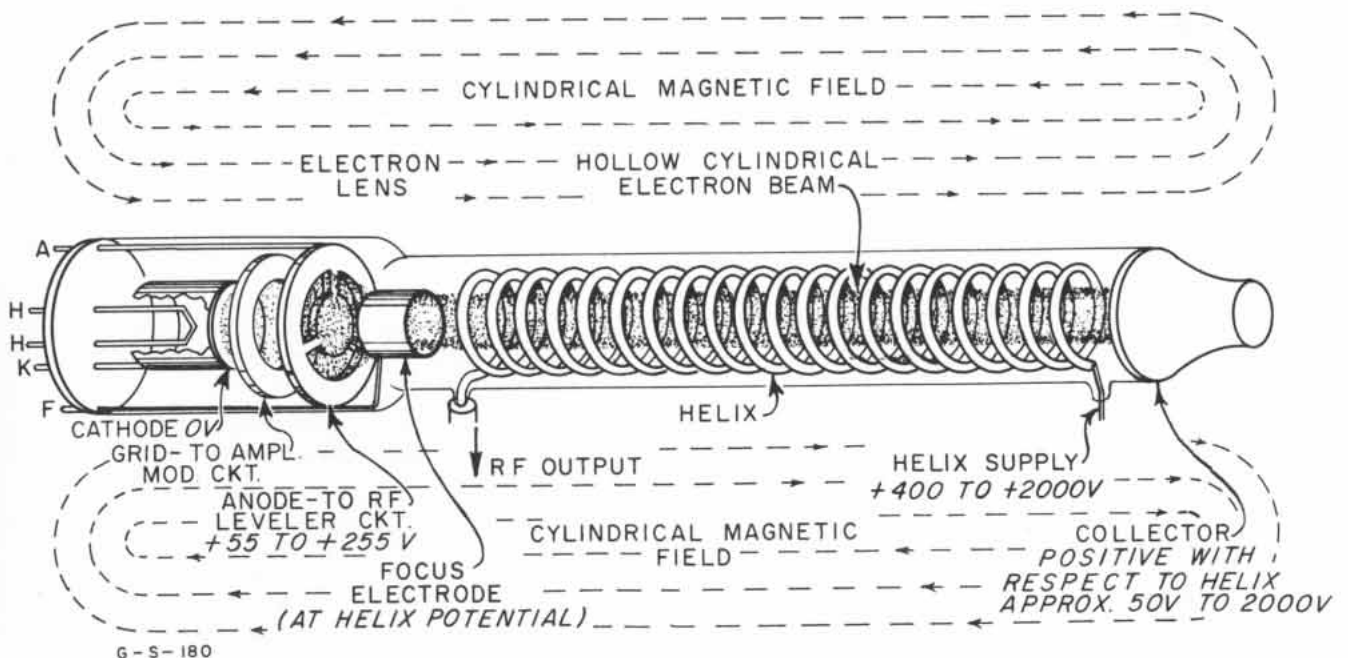

Figure 3-1. Backward-Wave Oscillator Tube Construction

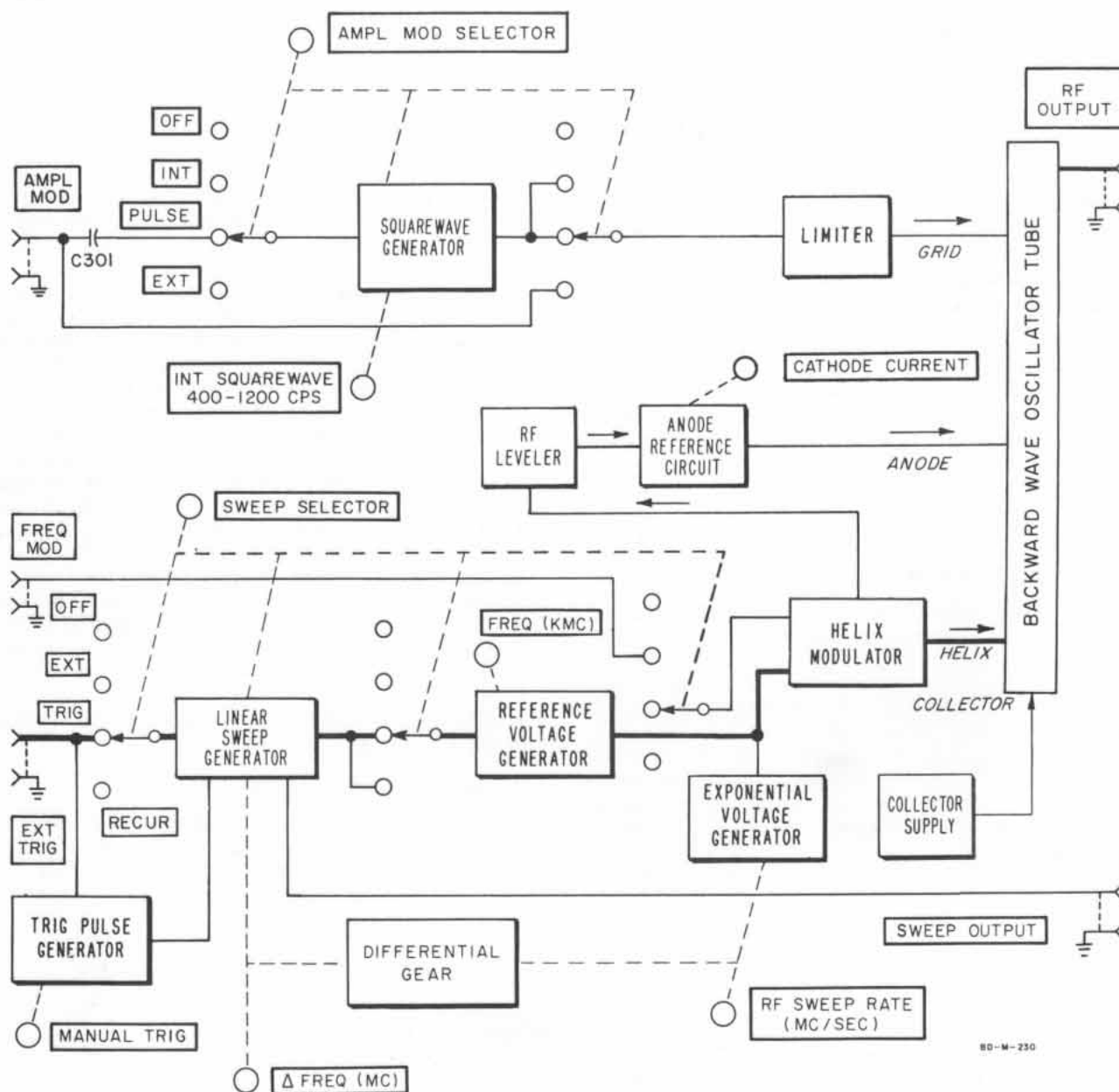

Figure 3-2. Block Diagram Model 686C Sweep Oscillator

output frequency vs helix voltage curve is exponential with the frequency change per volt change decreasing as rf output frequency increases. The frequency change per volt change at the helix varies somewhat from tube to tube, but will be approximately 2.5 mc/volt change at 12.4 kmc and 5 mc/volt change at 8.2 kmc.

Control of the operating conditions of the bwo thus becomes simply one of controlling the potentials supplied to the tube in an accurate and predictable manner.

B. OUTPUT POWER

The power output is determined by electron beam density, which is controlled by the cathode-to-anode voltage. The cathode is essentially at ground, and the level of the anode voltage is determined by the setting of the front panel CATHODE CURRENT control.

C. MODULATION

The oscillator can be amplitude modulated at any per cent from 0-100% by varying the voltage on the control grid from approximately 0 to 20 volts negative with respect to the cathode.

The pulse modulation grid voltage "on" condition is essentially the same as the cw condition, and incidental fm is negligible.

D. FACTORS AFFECTING FREQUENCY

The frequency of oscillation of the bwo tube is determined by the velocity of the electron beam. This in turn is determined by the voltage difference between the cathode and the helix. The frequency of oscillation is also affected by the anode voltage and the magnetic field flux density.

The change in frequency due to changes in the magnetic field is essentially constant at any operating frequency. With the solenoid used in this instrument, the frequency will be changed approximately 100 kc/volt change in magnet supply voltage. The supply to the magnet is very well regulated so that variations and ripple are held to very low levels. This effectively eliminates the solenoid supply as a source of frequency change.

3-3. RF LEVELER AND ANODE REFERENCE CIRCUIT.

The leveler circuit is an internal device which reduces power variations across the band to ± 1.25 db or less. This is accomplished by programming the anode voltage to compensate for coarse grain power characteristics (figure 3-3) of the two tube.

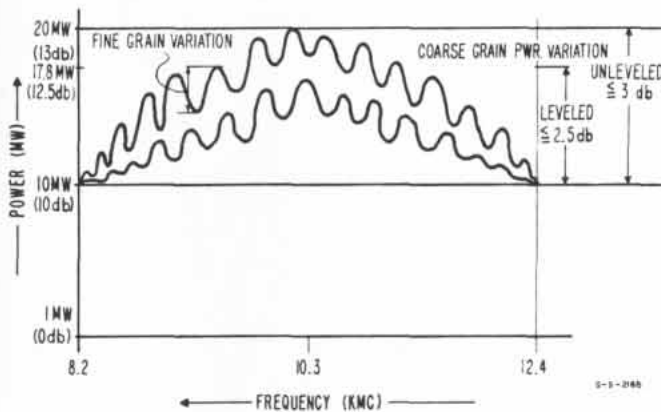

Figure 3-3. Detected Waveform

The leveler circuit is functioning in both the cw and recurring mode of operation. In the RECUR position the leveler circuit compensates for coarse grain power variations throughout the frequency range (8.2 to 12.4 kmc). In cw operation the leveler circuit holds the output power level constant (within ± 1.25 db) for each selected output frequency. To describe the swept anode voltage, the leveler circuit will be discussed with the SWEEP SELECTOR switch in the RECUR position and with the full band being swept.

The two output frequency and power level are both voltage controlled. For a linear change in output frequency, an exponential voltage is applied to the helix (figure 3-2). The voltage proportional to the helix waveform (figure 3-4A) is simultaneously sent through the leveler circuit, reshaped, and applied to the two anode. The anode voltage waveform is composed of four variable segments. Segments 1 and 2 (figure 3-4B) are shaped by Cathode Follower V303A and associated circuitry (figure 3-5). Segments 3 and 4 (figure 3-4C) are shaped by Inverter Amplifier V302A and associated circuitry. The four segments are combined at the junction of CR302 and CR303 (figure 3-4D). The resultant waveform is then applied through Reference Amplifier V302B and Cathode Follower V303B to the two anode.

The leveler circuit functions as follows: A voltage proportional to the helix voltage is taken from the common cathode of Differential Amplifier Modulator V105, and applied through R321 (Segment 1 Adj, figure 3-5) to the grid of Cathode Follower V303A. Potentiometer R321, by varying the amount of signal to V303A, determines the slope of Segment 1 (see figure 3-4B). The waveform of Segment 1 (taken from the cathode of V303A) is an exponentially decaying voltage which starts at +150 volts. At a point determined by the setting of R324 (Segment 2 Adj, figure 3-5) diode CR302 opens (no conduction) causing a plateau in the waveform. This plateau is Segment 2 (see figure 3-4B). Crystal diode CR302 remains open for the duration of the sweep.

While Segments 1 and 2 are being formed, the exponential voltage at the cathode of Differential Amplifier V105 is applied to the grid of V302A through the potentiometer R315 (Segment 3 Adj, figure 3-5). As CR303 is open (not conducting), no output from V303A appears at the junction of CR302 and CR303. At a time determined by the bias on CR303, the positive-going voltage on the plate of V302A causes CR303 to close. The

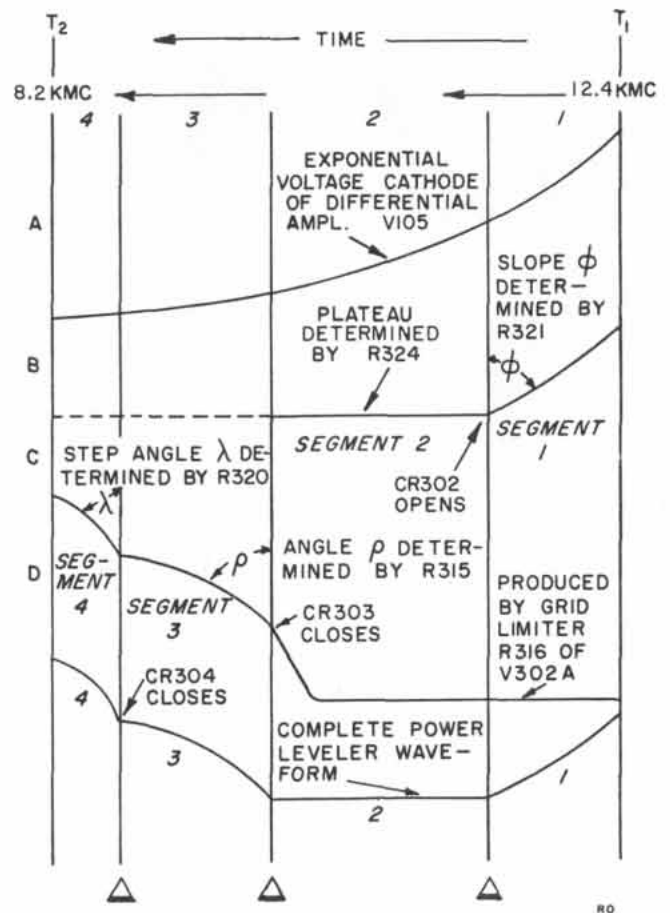

NOTE:
△ THE POINTS AT WHICH THE SEGMENTS MEET, MOVE BOTH HORIZONTALLY AND VERTICALLY.

Figure 3-4. Adjustable Segments of Compensated Helix Voltage

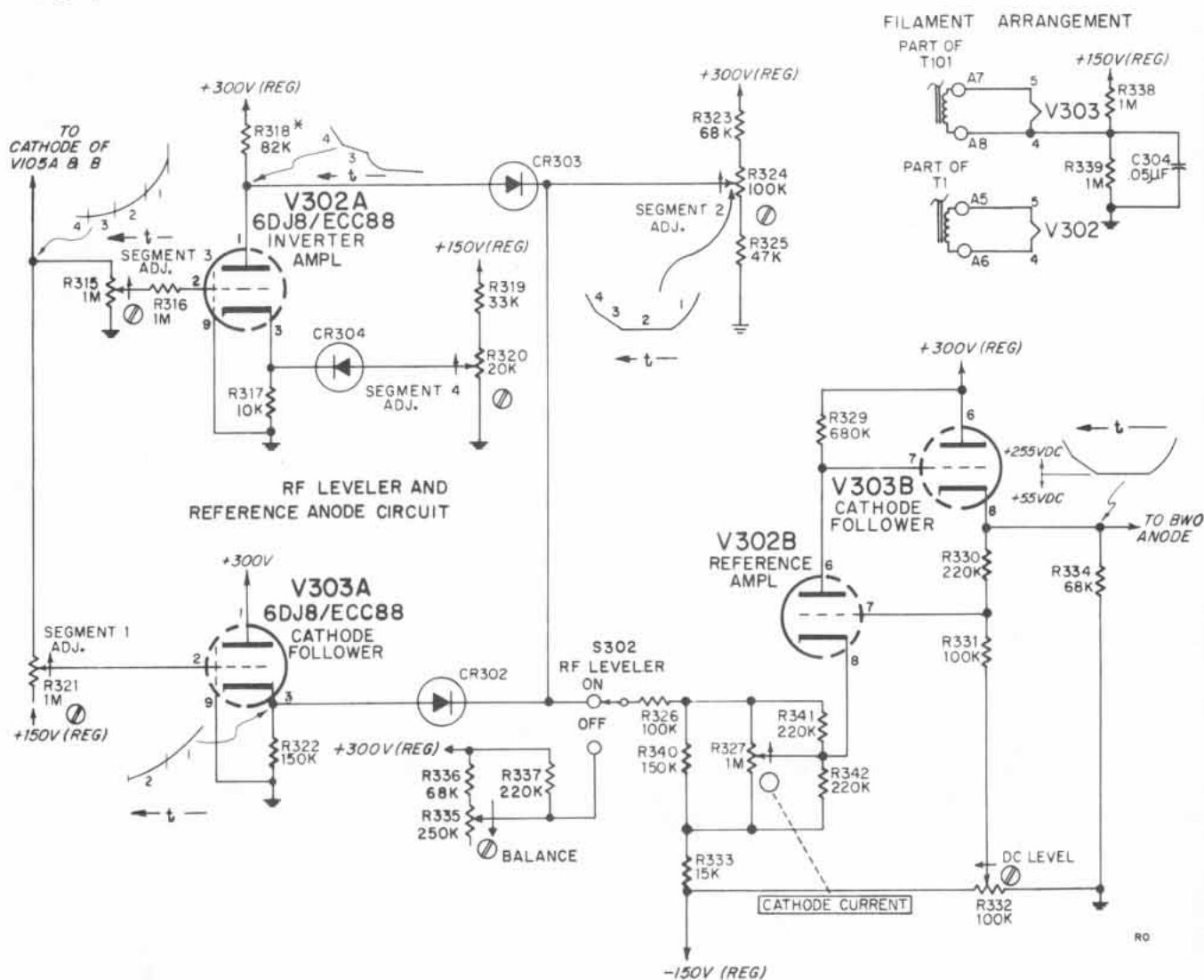

Figure 3-5. RF Leveler Circuit

rising voltage at the junction of CR302 and CR303 is Segment 3 (figure 3-4C). The slope of Segment 3 is determined by the setting of R315 (Segment 3 Adj, figure 3-5). The cathode of V302A follows the negative-going voltage applied to the grid of V302A. At a time determined by the voltage at the arm of the potentiometer R320 (Segment 4 Adj, figure 3-5), CR304 will conduct, effectively decreasing the cathode resistance of V302A and increasing the gain of the circuit. This increased gain accounts for Segment 4 (figure 3-4C). The composite waveform (figure 3-4D) at the junction of CR302 and CR303 is applied to the Reference Amplifier V302B.

Characteristically, the reference anode voltage vs the reference power level varies from one tube to another. Thus to obtain the reference power level specified by the manufacturer, the reference anode voltage must be variable. The purpose of the Reference Amplifier, V302B, is to supply a variable dc reference voltage between +55 and +255 volts at the bwo anode. Resistor R327 is a front panel control (CATHODE CURRENT)

that varies the bwo output power from 0-100%. The waveform at the plate of V302B is dc coupled to the grid of the Cathode Follower V303B which in turn applies the complete waveform to the bwo anode. Degenerative feedback from the cathode of V303B is applied to the grid of V302B through R330 to reduce drift caused by tube aging and line voltage variations. When RF LEVELER switch S302 is in the OFF position, the cathode of V302B is placed at a dc reference by the combined settings of R327, R332, and R335. The purpose of the RF LEVELER OFF position is to make higher power outputs available at certain frequencies. Rf leveling action is referenced at the low power point, consequently power output is sacrificed to obtain the desired leveling action.

3-4. AMPLITUDE MODULATOR.

Signals for amplitude-modulating the rf power are applied to the control grid of the bwo tube, through Amplitude Modulator Circuit. Voltage from the internal 400- to 1200-cps square-wave generator or

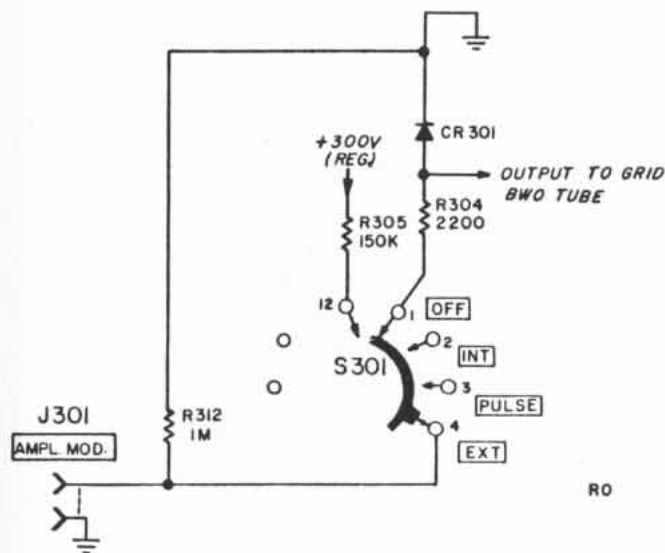

Figure 3-6. Amplitude Modulation EXT. Position

signals (pulse, square wave, sine wave, or complex wave) from an external source may be used to modulate the rf output under various types of operation.

A. CW OPERATION

In cw operation (AMPL. MOD. SELECTOR on OFF), diode CR301 (figure 4-24) clamps the bwo control grid to ground. The rf output level is determined by the voltage on the anode, which is adjusted by means of the CATHODE CURRENT control.

B. INTERNAL SQUARE-WAVE OPERATION

With the AMP. MOD. SELECTOR on INT., dual triode V301 (figure 4-24) operates as a symmetrical free-running multivibrator. The frequency of the square wave is determined by the charge and discharge time of C302 and series-connected R302 and R303 (INT. SQ. WAVE FREQUENCY control). The symmetry of the square wave is set by adjusting (with R310) the dc bias of the B section of V301. The two adjustments are slightly interdependent. The square-wave amplitude is clamped to ground through crystal diode CR301. Thus the level of the rf output during the "on" portion of the square-wave cycle corresponds to the cw level (set with the CATHODE CURRENT control).

C. PULSE OPERATION

With the AMPL. MOD. SELECTOR switch on PULSE, the AMPL. MOD. jack is connected, through capacitor C301, to the grid of the A section of V301. Dual triode V301, with diode CR301 in the plate circuit of its B section, is operated as a limiting amplifier to provide constant amplitude pulses to the control grid of the bwo tube. The A section of V301 is operated as a cathode follower and the B section as a single stage amplifier. Before an externally-supplied pulse is received, the B section of V301 is conducting. The B-section plate, through contacts on the SELECTOR switch, is tied to the control grid of the bwo tube; both are tied to the anode of diode CR301. With V301B conducting, the bwo tube is cut off. The incoming positive

pulse, coupled by capacitor C301 to the V301A grid, is coupled to the V301 cathode, and turns off the B section. The B section plate rises, and is clamped to ground through diode CR301. Thus during the "on" time of the pulse, the level of the bwo rf output corresponds to the cw level (set by the CATHODE CURRENT control).

D. EXTERNAL OPERATION

With the AMPL. MOD. SELECTOR in the EXT. position, the 300 volt source is removed, eliminating bias current to diode CR301. The diode CR301 remains between the grid of the bwo and ground, so the bwo grid cannot go positive from ground. The grid of the bwo tube is returned through a 1-megohm resistor R312 to ground (figure 3-6) which permits application of positive input pulses provided they are either capacitively coupled or superimposed on an external -20 volt bias. The coupling capacitor must be sufficiently large and the frequency such as to maintain a charge (grid bias) between modulation pulses.

NOTE

If the signal source has a large internal capacitor in series with the output (example, Model 212A), and the duty cycle is such as to allow the capacitor to retain sufficient charge between cycles, no external capacitor is needed.

Generally, the external modulation facility is used for fast pulse modulation. Amplitude modulating the bwo tube with a sine wave is also possible, but introduces frequency pulling.

3-5. HELIX MODULATOR.

The Helix Modulator consists of three major sections: The Linear Sweep Generator, the Helix Supply Reference Voltage Generator, and the Exponential Voltage Generator. The Linear Sweep Generator generates: 1) a precision time interval to start and stop the Exponential Voltage Generator thus determining the time duration of the rf output sweep, and 2) a linear sweep output voltage concurrent with the rf output sweep. The length of the precision time interval is governed by the settings of both the Δ FREQUENCY and the RF SWEEP RATE controls.

The Helix Supply Reference Voltage Generator determines the rf output frequency for cw operation and the starting frequency for swept operation. The output of the Reference Voltage Generator is continuously adjustable by means of the FREQUENCY (KMC) dial which controls the setting of variable resistor R236 in the cathode circuit of Control Tube V207A. The Reference Voltage Generator determines frequency by supplying the reference voltage for the Regulated Helix Supply and the regulated dc voltage for the Exponential Voltage Generator.

The Exponential Voltage Generator produces an exponentially-varying voltage to drive the bwo helix for internal sweep operation. Since the voltage-vs-time curve of the Exponential Generator is essentially the same shape as that of the bwo helix voltage vs frequency characteristic, the bwo produces a linear rf output sweep.

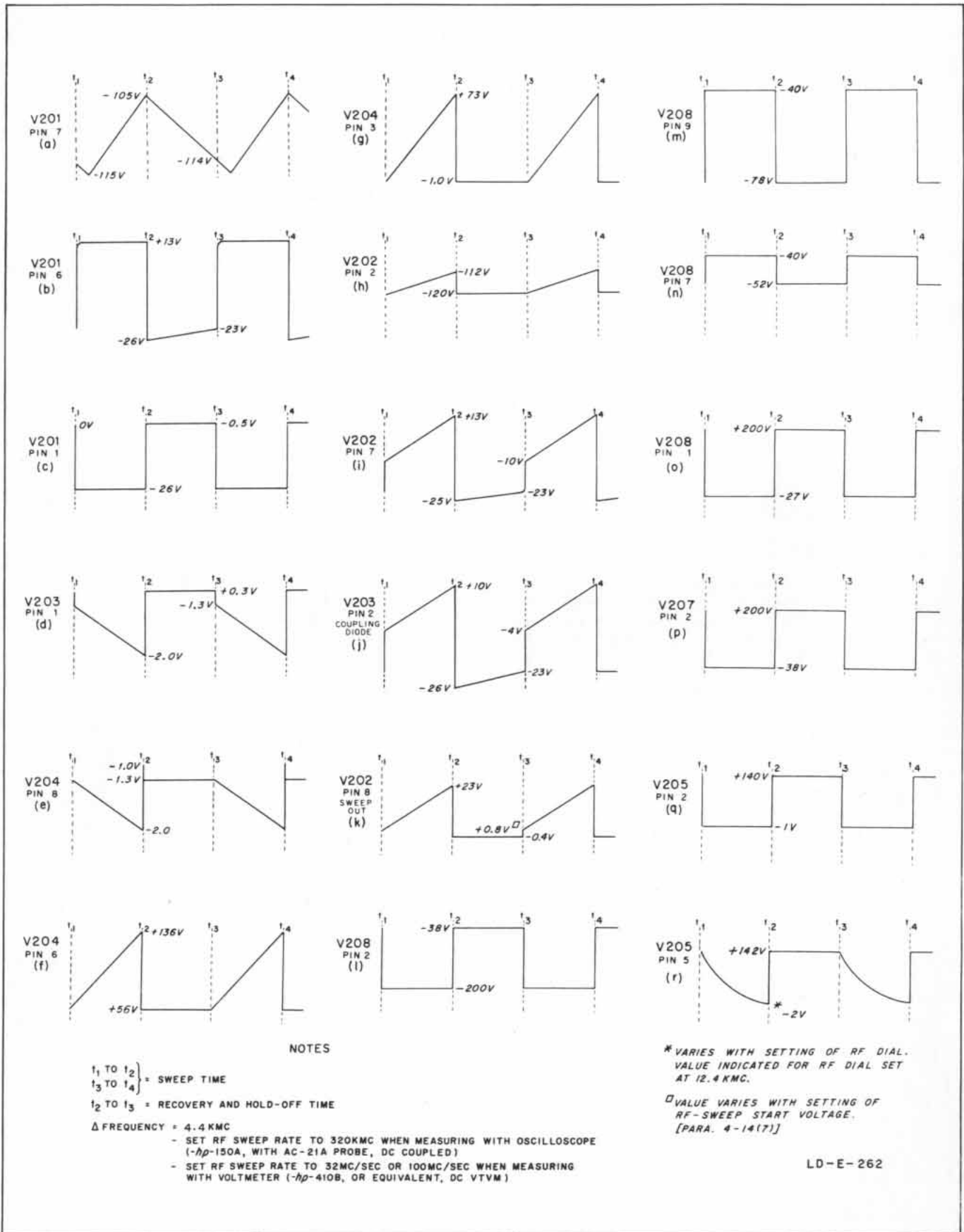

Figure 3-7. Frequency Modulator Waveforms

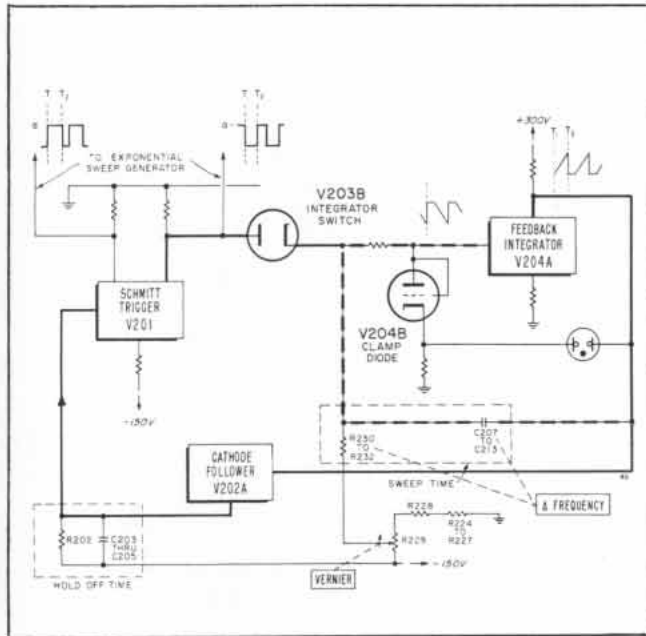

Figure 3-8. Simplified Schematic of Linear Sweep Generator

3-6. LINEAR SWEEP GENERATOR.

The Linear Sweep Generator (figure 3-8) consists of a Miller Feedback Integrator (V204A) which generates a linear voltage sweep whose slope can be adjusted by changing the charging rate of the integrator capacitor (C207 to C213). The Δ FREQUENCY (MC) range switch (part of which is shown in figure 3-8) changes the values of the integrator resistors (R230 to R232) and capacitors (C207 to C213) to obtain step changes in slope, while the VERNIER (R229) on the Δ FREQUENCY (MC) switch varies the capacitor-charging voltage to provide slope adjustment between steps. The Feedback Integrator is started and stopped by Schmitt Trigger V201 which shunts the integration circuit to ground through Integrator Switch V203B to prevent sweeping, and releases it from ground to start a sweep.

The Feedback Integrator is made automatically recurrent, and the output is made constant in amplitude by operating the Schmitt Trigger (see figure 3-8) from the output of the Integrator. After being unlocked by the Schmitt Trigger, the integrating circuit charges to a predetermined level established by the sensitivity of the Trigger. At this level, the feedback voltage causes the Trigger to change state. The Trigger relocks the Integrator Circuit and terminates the sweep with a rapid flyback. Trigger tube V201A is held conducting for a predetermined period of time by a charge on C205 and supplementary capacitors to allow time for circuit recovery. As the capacitors discharge, Trigger V201 returns to its original state which, in turn, unlocks the Integrator Circuit so it can generate another sweep.

When the SWEEP SELECTOR (S202) is set to TRIG., Schmitt Trigger V201 is biased by voltage divider R204 and R205 to hold the A side conducting. Thus it does not retrigger, except upon receipt of an externally-generated positive pulse or a pulse provided by the

front panel push button (S201, MANUAL TRIGGER). The positive pulse instantaneously raises the voltage on pin 6 (V201) to almost zero volts. This positive-going pulse is transferred to pin 2 causing the B side to conduct which in turn cuts off the A side.

With the SWEEP SELECTOR switch set to RECUR, V201A conducts before a sweep starts because its grid is held positive by the charge on capacitor C205 placed there by Cathode Follower V202A when the previous sawtooth went positive. In this state, the A-side plate voltage and B-side grid voltage are down, while the B-side plate voltage is up. With the V201B plate voltage up, Integrator Switch V203B conducts and locks the Integrator Circuits to ground through R208. As the charge on C205 leaks off through R202, the A-side grid voltage reaches a point (t_1 , figure 3-7a) where it causes the A side of the Schmitt Trigger to cut off and the B side to conduct.

At this time, V201 A-side's plate voltage and B-side's grid voltage go up, and B-side's plate voltage goes down, cutting off (opening) Integrator Switch V203B. Opening the Switch permits the grid of the Feedback Integrator and one side of the Integrator capacitor (C207 through C213) to charge through one of the resistors (R230 to R232) to a negative voltage determined by the setting of R229. As the capacitor charges negatively, the voltage at the grid of V204A falls (figure 3-7e). The plate voltage rises approximately 10 volts for each 0.1 volt the grid falls (100 being the approximate gain of this stage). The Integrator tube (V204A), by virtue of this gain and the degenerative feedback due to the Integrator capacitor connected between its plate and grid, has a small grid-voltage change for a large plate voltage change (see figure 2-7e and f). Since the resistor connected to the grid of V204A is returned to -50 volts or greater and the grid voltage only changes about 0.7 volt (plate voltage change of approximately 80V) the current through the resistor is nearly constant. Therefore Integrator tube V204A, by means of its gain, allows the Integrator capacitor to charge to a large voltage while maintaining a nearly constant charging current. The change in voltage across C213 thus rises at a linear rate.

As the plate of V204A rises during integration, it reaches a level (t_2 , figure 2-7f) where the voltage coupled through Cathode Follower V202A to Schmitt Trigger V201 (t_2 , figure 3-7a) switches the V201 B-side plate up, locking the Integrator grid to ground and stopping the integration process. Upon being stopped, the Integrator plate voltage drops rapidly from its high positive voltage. The plate voltage is coupled through a 63-volt constant-voltage neon lamp and diode clamp (triode V204B connected as a diode) back to the Integrator grid. As the Integrator plate drops, V204B's cathode drops (figure 3-7g). When V204B's cathode voltage drops to -1.0 volt, V204B's plate voltage is -1.3 volts (due to contact potential). The Integrator grid is clamped at approximately -1.3 volts and the circuit stabilizes. During integration, diode V204B is cut off (opened) as its plate is carried negatively when Integrator Switch V203B releases the circuit from ground (figure 3-7e). This removes the Clamp Circuit and allows the grid of V204A to go in a negative direction.

The length of time that the Schmitt Trigger A-side is held conducting to allow for circuit recovery is determined by the positive charge placed on C205 by V202A. For the longer sweeps, the Δ FREQUENCY switch, S203, adds additional capacity to C205 to lengthen the discharge time.

The linear sweep voltage from the Feedback Integrator plate is coupled by output Cathode Follower V202B to the SWEEP OUTPUT connector. Two other signals are coupled to the grid of V202B. First, a negative voltage from the plate of V201A is coupled through diode V203A to cut off V202B during the fly-back time and at all times before a sweep starts (see figure 3-7j). Second, a dc voltage is applied and adjusted by R217 which will give an instantaneous 1.5 volt output from J203 when Schmitt Trigger V201 flips and opens coupling diode V203A removing the negative bias on the grid of V202B (see figure 3-7k). The instantaneous initial positive output voltage produces a thin section of trace on the cro which separates the beginning of the main trace from the bright dot, or vertical line, which occurs during circuit recovery time.

3-7. HELIX SUPPLY REFERENCE VOLTAGE AND EXPONENTIAL VOLTAGE GENERATORS.

The frequency of the rf output of the sweep oscillator is determined by the amplitude of the voltage applied to the bwo helix. The amplitude of the helix voltage is controlled by varying the reference voltage supplied to the Regulated Helix Supply (figures 3-9 and 4-26). For cw operation, the reference voltage, supplied by the Reference Voltage Generator, has a constant amplitude, the level being set by means of the FREQUENCY (KMC) dial. For sweep operation, the reference voltage is supplied by the Exponential Voltage Generator. The amplitude of this voltage starts at a value established by the setting of the FREQUENCY (KMC) dial, and then decreases exponentially. The resulting frequency output is a linear rf sweep, the bwo being an exponential-law device. Operation of the Reference and Exponential Voltage Generators is briefly described below.

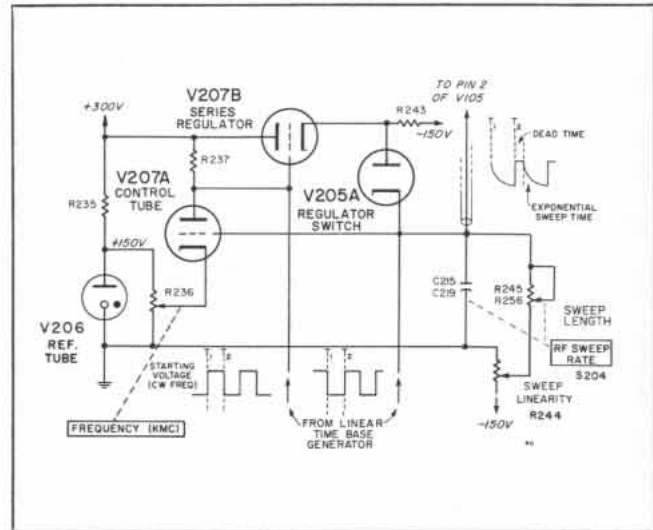

Figure 3-9. Simplified Schematic of the Exponential Sweep Generator

A. REFERENCE VOLTAGE GENERATOR

Basically, the Reference Voltage Generator (figures 3-9 and 4-26) is a typical voltage regulator with a source of reference voltage (Reference Tube V206), a Control Tube (V207A) which compares the reference voltage with a sample of the Reference Voltage Generator output, and a Series Regulator (V207B). A signal from the control tube controls conduction through the series regulator in such manner that any tendency of the output to deviate from the desired level is compensated for.

The output of V207B is brought through Regulator Switch V205A and applied 1) to Differential Amplifier V105 in the Regulated Helix Supply (figure 4-22) and capacitor C215 (in the line to V105), and, 2) to the grid of Control Tube V207A to provide the sample of output voltage required by the regulator. Status of tubes during cw operation is shown in table 3-1.

Table 3-1. Conditions of Tubes During CW and RF Sweep

Operation	State of Circuit	V201A	V201B	V208A	V208B	V207A	V207B	V205A	V205B
CW		Cond.	C. O.	C. O.	Cond.	Cond.	Cond.	Cond.	C. O.
RF Sweep	Before rf sweep starts; Exp. Gen. capacitors charging	Cond.	C. O.	C. O.	Cond.	Cond.	Cond.	Cond.	C. O.
	RF sweep starts; Ref. Volts Gen. turned off	C. O.	Cond.	Cond.	C. O.	C. O.	C. O.	C. O.	Cond.
	RF sweep reaches low end: Schmitt Trigger trips or Decaying voltage reaches -1.1 volt	Cond.	C. O.	C. O.	Cond.	Cond.	Cond.	Cond.	C. O.
		Cond. = Conducting				C. O. = Cut off			

The Reference Voltage Generator's output level can be varied from the front panel, providing the means for selecting the frequency of the rf output. In addition it is possible to electronically turn off the Reference Voltage Generator for the precise predetermined time interval required for sweep operation. The circuit sequences which effect this action are described in the next paragraph.

B. EXPONENTIAL VOLTAGE GENERATOR.

Operation of the Exponential Voltage Generator requires all the circuits shown in figure 4-26. Current for charging the capacitance in the rc circuit of the Exponential Voltage Generator is supplied by the Reference Voltage Generator. As soon as the Reference Voltage Generator is turned off, the charged capacitor(s) starts to discharge through its corresponding resistor network, and it is this exponentially decaying voltage which is fed to the Regulated Helix Supply. Turn-off of the Reference Voltage Generator (as well as its turn-on after a precise predetermined time) is under the control of the Linear Sweep Time Generator. The rate at which the capacitor discharges (and thus the rate at which the rf frequency is changing) is determined by the values of capacitance and resistance selected by the RF SWEEP RATE (MC/SEC) switch (S204). The Exponential Voltage Generator is turned off when the Reference Voltage Generator is again turned on by the Linear Sweep Time Circuit. How long the voltage is permitted to decay is thus determined by the Linear Sweep Time Circuit which is controlled by the Δ FREQUENCY switch (S203). Thus the width of band swept (band distance = sweep time x sweep rate) is determined by the settings of both S203 and S204. (The Δ FREQUENCY switch determines time though it is calibrated in terms of "distance.") Circuit action is discussed in more detail below.

In the following discussion of circuit action the term "sweep" refers to the sawtooth voltage produced by the Linear Sweep Time Generator; the term "rf sweep" refers to the output of the bwo tube (figure 4-22). Operation of the Linear Sweep Time Generator is described in paragraph 3-6, and only that part of the action which is pertinent to an understanding of the Exponential Voltage Generator; will be discussed here. Condition of main tubes at various stages of circuit action is shown in table 3-1.

With the instrument set for internal sweep operation, the Linear Sweep Time Generator is producing a sawtooth voltage. While the voltage at the output of Feedback Integrator V204A is rising, the A section of Schmitt Trigger V201 is cut off and the B section is conducting. Feedback from V204A is returned to the grid of V201A, and when the amplitude of the sawtooth reaches the Schmitt Trigger upper hysteresis limit, V201 changes state: the A section starts to conduct and the B section cuts off. The feedback also charges capacitor C205 in the V201A grid circuit, and this charge holds V201A conducting during the sawtooth dead time.

With V201A conducting there is a positive signal on the grid of V207B, supplied through V208A; this holds Series Regulator V207B in conduction. With V201B

cut off, the cathode of Regulator Switch V205A is pulled in a negative direction, holding V205A in conduction. In the same manner as in cw operation, current through V207B, diode CR204, and V205A establishes the charge on capacitor C215 at a level which corresponds to the setting of the FREQUENCY (KMC) dial.

During the sawtooth dead time, the charge on capacitor C205 leaks off through resistor R202. When the voltage across C205 drops to the Schmitt Trigger lower hysteresis limit, V201 again changes state: V201A cuts off and V201B turns on. This results in a negative signal on the V207B grid, cutting off conduction through the Series Regulator which 1) opens Regulator Switch V205A and 2) closes Clamp V205B. With supply voltage removed, capacitor C215 starts to discharge through the resistors selected by the RF SWEEP RATE switch. Thus the voltage applied to V105 in the Regulated Helix Supply starts to fall exponentially, causing the frequency of the rf sweep to change at the rate selected by the RF SWEEP RATE switch. The rc network discharges toward the potential on the slider of variable resistor R244, the RF Sweep Linearity Adjustment.

In the usual case the voltage decay will continue until the amplitude of the sawtooth voltage again reaches the Schmitt Trigger upper hysteresis level, and conducting V201A turns on the Reference Voltage Generator. To protect the bwo tube, however, circuitry is included to prevent the voltage from decaying to too low a level. The Clamp V205B when conducting holds the plate of V205A at approximately -1.1 volts. If the Linear Sweep Time Generator does not turn on the Reference Voltage Generator before the exponential voltage decays to approximately -1.1 volts, V205A will start to conduct and will clamp the exponentially-decaying voltage to -1.1 volts.

In the usual case the voltage decay will continue until the amplitude of the sawtooth voltage again reaches the Schmitt Trigger upper hysteresis level, and conducting V201A turns on the Reference Voltage Generator. To protect the bwo tube, however, circuitry is included to prevent the voltage from decaying to too low a level. The clamp V205B when conducting holds the plate of V205A at approximately -1.1 volts. If the Linear Sweep Time Generator does not turn on the Reference Voltage Generator before the exponential voltage decays to approximately -1.1 volts, V205A will start to conduct and will clamp the exponentially-decaying voltage to -1.1 volts.

Thus the length of time the voltage decay is permitted to continue (unless it reaches -1.1 volts first) is determined by how long the A section of Schmitt Trigger V201 (and therefore the Reference Voltage Generator) is cut off. This period is the time required for the amplitude of the sawtooth to reach its maximum positive value plus the sweep dead time (the time required for the charge on C205 to leak off through resistor R202). This total time is determined by components switched into the Linear Sweep Time Generator circuit by the Δ FREQUENCY switch (S203).

The voltage at the center tap of resistor R236 is established by current flowing through resistors R233,

R234, R263, R240, diode CR202, and the A section of V201. In cw operation (V201A conducting), diode CR202 is forward-biased and the junction of R233 and R263 is practically at ground. CR202 clamps the junction of R233 and R263 so it cannot go negative. Resistor R263 establishes the voltage at the cathode of Coupling Diode V203A at such a level that V203A will not close until V201A starts to conduct (when the sawtooth reaches maximum level and the flyback starts). Tap resistors R234 and R240 change the voltage characteristic of the V207A cathode circuit in such manner that dial calibration is improved (crowding at the low-frequency end is reduced). Diode CR204 is a 55-volt breakdown diode which maintains a constant 55 volt difference in potential between cathode of V207B and plate of V205A.

Front panel controls Δ FREQUENCY (MC) S203, and RF SWEEP RATE (MC/SEC) S204, are operated through differential gears, and are so arranged that a combination which would require a sweep time of less than 0.0135 second is prevented. Thus, though the Δ FREQUENCY selector is the control for switch S203, the Δ FREQUENCY selector will also operate switch S204 if the RF SWEEP RATE selector is set for too high a rate for the sweep band selected. In the same manner, the RF SWEEP RATE selector will operate switch S203 if the Δ FREQUENCY switch is set for too short a sweep time (too narrow a frequency band) for the sweep rate selected.

3-8. REGULATED POWER SUPPLIES.

In addition to the Regulated Magnet Power Supply, there are five regulated voltages generated in the 686C: a) the -150 Volt Regulator which is not referenced to any other supply but affects all other supplies, b) the +300 Volt Regulator which is referenced to the -150 Volt Supply, c) the Helix Regulator which utilizes both the -150 Volt and +300 Volt Supplies, d) the Collector Regulator which is referenced to the Helix Regulator to determine its output voltage, and e) a voltage regulator in the Frequency Modulator which provides a reference for the Helix Regulator. The regulators are fed by a voltage doubler consisting of CR101, C102, and C103.

The sequence of operations upon applying line power to the 686C and the operation of the helix protective relay are explained on the voltage and resistance diagram (figure 4-19).

The operation of all the voltage regulators is similar, so only the operation of the -150 volt regulator is explained.

A. THE -150 (REG) POWER SUPPLY

In the -150 Volt Regulated Supply, CR105 and CR106 are two half wave series connected rectifiers which supply approximately 420 volts to the Regulator Series Tube V107B. Since the output voltage is negative with respect to ground the cathode is grounded. The grid to cathode voltage of V107B is adjusted to class A operating conditions and the tube acts like a variable resistor which adjusts its resistance to maintain a constant voltage on the -150 volt bus. Thus at normal

line voltage, the tube has approximately 270 volts drop from plate to cathode.

V108 is a Glow Discharge Reference Tube which maintains a constant 88 volt drop across its terminals. This constant voltage is applied to the grid of the Differential Amplifier Control Tube V109. The cathode of the triode section will maintain a constant 1 volt difference with the grid potential and thus keeps a constant 89 volt difference between the -150 volt bus and the cathode of the pentode section. Voltage divider R147, R148 and R149 provides the proper fraction of the -150 volts for the control grid of the pentode section.

R148 adjusts the exact value of the bias so that the voltage at the grid of the Series Tube V107B is held at the correct value. If the -150 volt bus tries to increase toward -151 volts, the increase will also make the control grid (pin 2) of V109 go in a positive direction with respect to the cathode. (The cathode is held at a constant voltage with respect to the -150 volt bus by the Reference Tube V108 and cathode follower Triode section in V109.) The positive going grid (pin 2) causes increased plate current to flow through the pentode section and R146. This causes increased voltage drop which lowers the grid voltage on V107B. The increased resistance of V107B brings the voltage back toward -150 volts. If the -150 volt level tends to decrease, the process is the same but in the reverse direction. C123 is a coupling capacitor which couples ac ripple directly to the grid of the Control Tube which in turn acts to regulate it out of the output in the same manner as a dc change. This results in very low values of ripple voltage in the regulated output.

B. THE +300 (REG) VOLTS SUPPLY

The +300 Volt Supply Circuit is similar to that of the -150 Volt Supply except it is referenced to -150 volts and it includes a ripple-compensating voltage divider (R137 and R138) from the unregulated output to ground. The voltage tap-off from the divider is applied to the screen grid of V107A (see figure 4-22). Compensating action of this arrangement is described in subparagraph C below.

C. THE HELIX (REG) SUPPLY

The Helix Regulator operation is similar to the 300 Volt Regulated Supply, but is more elaborate due to the extreme range of voltage control necessary, and because modulating voltages must be introduced. The Voltage Control Tube function requires a single-ended amplifier V103 that is driven by Differential Amplifier V105. The Differential Amplifier also serves as the Helix Voltage Modulator. Since the regulated Helix voltage must be capable of being swept over a 1600-volt range, Control Tube V103's plate voltage must also swing over this voltage range. Since two different helix modulating signals must also be applied to the Voltage Regulator, and since a greater order of regulation is necessary for helix operation, two stages of voltage amplification are used to obtain greater gain and bandwidth.

The reference voltage for the Helix Regulator is obtained from a voltage regulator in the Frequency Modulator, which is applied to one side of Differential

Amplifier V105. Also applied to V105 are: 1) Frequency modulation voltages from the FREQ. MOD. jack when SWEEP SELECTOR is in EXT. 2) Degenerative feedback voltages to maintain a constant internal impedance in the Helix Supply. The sample voltage from the helix regulator output, a calibrating voltage obtained from voltage divider stick R132, R133, R134, and R135 is connected to the other grid of the Differential Amplifier. The calibrating voltage divider stick contains potentiometers which set the upper and lower helix voltage limits and, in turn, the upper and lower rf output frequency limits. The sweep voltages, which produce the rf swept output, are controlled exponential decays in the regulated reference voltage obtained from the Frequency Modulator.

The sample voltage from the Helix Regulator output is fed through a frequency-compensated divider composed of R122, R154, R150, R151, C114 and R131 through R135, C116, and C117. Coupling from the plates of Differential Amplifier V105 to Voltage Control Tube V103 is through compensated divider V110, R127, and R128 to obtain the correct dc voltage level for the grid of V103. All of these compensated coupling networks and the frequency-compensation network in the Cathode Circuit of V103 serve to control the gain in each step of the regulator feedback loop in such a manner that the internal impedance of the supply remains constant at 12 ohms over the required frequency range.

The collector supply is composed of two series tubes V102A and B in series controlled by voltages from a divider powered by the regulated helix voltage. Their purpose is to keep the voltage between the collector and helix within acceptable limits. Two tubes are required in series to handle the maximum voltage that can occur, which is about 650 volts.

3-9. REGULATED CURRENT MAGNET SUPPLY.

The backward wave oscillator tube requires a powerful axial magnetic field to hold its hollow electron beam in focus throughout the full length of the helix. The magnetic field must be ripple-free and very constant. To this end, the magnet power supply is current regulated and maintains an exact magnetic field in spite of line voltage variations and temperature variations which change the dc resistance of the solenoid. To accomplish current regulation, a two-stage differential amplifier senses a voltage which is proportional to the magnet current and compares it against a stable reference voltage. The differential amplifier upon sensing any change in the magnet current, controls the internal resistance of tubes in series with the magnet, and holds the magnet current constant.

V1 and V2 are the series regulators (resistances), while V4 and V5 are the two-stage differential amplifier sensing the voltage drop in voltage divider stick R29, R30, R31. V3, operated from its own dc power source, provides a stable dc reference voltage against which the sampled voltage is compared. Resistors shunting the series regulators serve to carry a portion of the 0.7-ampere load imposed by the magnet. Grids of the series regulators have parasitic suppressor resistors while the cathodes have current equalizing resistors.

The dc for the magnet supply is obtained from a voltage doubler circuit which operates directly from the power line. One wire of the power source is connected in series with one of the filament windings of T101. This winding is poled so that it adds 6 volts to the supply voltage going to the silicon rectifier voltage doubler.

When the instrument is connected for 230-volt operation, the voltage doubler is supplied with 115 volts from one half of the primary of the power transformer T1 which is acting as a 2:1 auto-transformer. The fan motor and the high voltage transformer are operated from the other half of the transformer to minimize the unbalanced load on the two halves of the primary winding.

Extreme caution should be exercised when working in the magnet power supply section since many tube socket terminals, electrolytic filter capacitor terminals and cans, etc., are directly connected to the power line. The instrument chassis is grounded through the NEMA three-prong connector. An accidental short caused by a test probe, etc., will cause a direct short circuit on the power line. The high fault currents that will flow before the instrument fuses can blow may severely damage the instrument. The magnet supply ground is floating and is not related to any other ground in the instrument.

This voltage doubler circuit is used to eliminate an additional bulky power transformer. The magnet circuitry is separated from the rest of the instrument and the parts layout is such that a minimum number of points which are connected to the power line are exposed. The polarity of the grounded and ungrounded power conductors has been carefully controlled. If the instrument is used with a properly connected three-prong grounded receptacle, this polarity will be maintained as intended. For this reason, it is recommended that a three-prong to two-prong adapter not be used with this instrument.

3-10. HOW A HELIX BACKWARD-WAVE OSCILLATOR TUBE WORKS.

The backward-wave oscillator provides a flexible source of microwave energy that can be voltage-tuned over bandwidths from 1.5:1 to as high as 5:1. The output frequency of the backward-wave oscillator is determined by a frequency-selective feedback and amplification process rather than by resonant circuits as used in conventional microwave oscillators.

The backward-wave oscillator tube consists of: an electron gun, a helix structure and a collector at the far end of the helix (see figure 3-10). Physically, the backward-wave oscillator resembles the traveling-wave amplifier tube; although, for comparable frequencies it is larger in diameter and somewhat shorter in length. Another difference, not apparent from a visual inspection of the tube, is that the helical backward-wave oscillator uses a hollow electron beam with a strong concentration of the electrons near the helix. This hollow electron beam is focused along the length of the helix by a strong magnetic field supplied by an axial solenoid surrounding the tube.

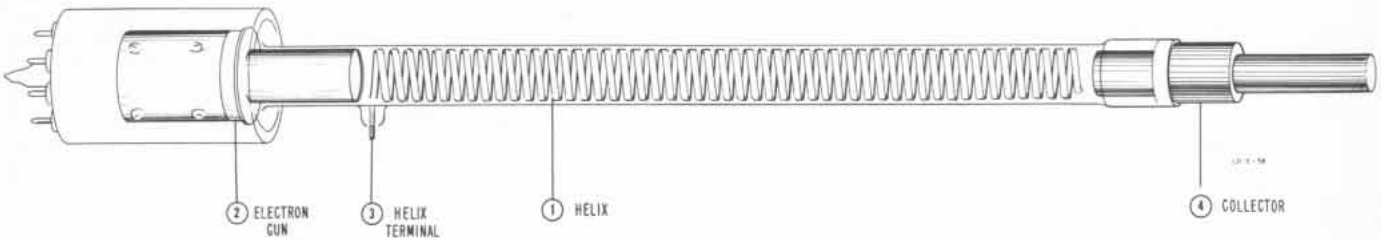

Figure 3-10. Backward-Wave Oscillator Tube

The rf output of the backward-wave oscillator is a result of the interaction between the electron beam and the electric fields accompanying a microwave signal present on the helix. The term "backward-wave oscillator" is quite appropriate for this tube since the rf energy moves and builds up in a direction opposite to that of the electron beam and is coupled out at the gun end of the tube via the helix terminal.

The operation of the backward-wave oscillator tube may be explained in terms of a series of feedback loops similar to those common to low frequency electronic circuits. Each of these regenerative loops can function as an amplifier or an oscillator and is designed so that the phase shift around the loop is one cycle. One of these feedback loops is shown in figure 3-11 where, using conventional terminology, the forward or μ circuit consists of a section of transmission line and the backward or β circuit is a unilateral amplifier connecting the output of the transmission line to the input. In this circuit positive feedback will occur when the amplifier gain becomes sufficiently high to overcome the loss in the transmission line and the $\mu\beta$ loop will oscillate at a frequency for which the total phase delay is one or more cycles.

If the amplifier is designed for limited high frequency response, oscillations will occur only when the phase delay is one cycle and the frequency of oscillation can be shifted by changing the phase delay in the amplifier. The essential feature of the voltage-tuned backward-wave tube oscillator is that the frequency of oscillation can be changed electrically by changing the phase delay in the amplifier.

Figure 3-12 shows a chain of identical regenerative feedback loops. Along the top of the chain is a series of transmission line sections that will support a wave

moving either to the right or to the left. Along the bottom of the chain is a series of unilateral amplifiers in which signals can pass only in the left-to-right direction. Each loop then consists of a transmission line, two coupling capacitors and an amplifier transmitting from left to right. In operation, positive feedback, which leads to regenerative amplification or oscillation, occurs utilizing a wave going from right to left on the transmission line when the phase delay in a single loop is just one cycle. The total phase delay around a group of n loops will then be n cycles.

For low values of amplification, the chain of loops will act as a regenerative amplifier operating at the frequency which provides positive feedback. However, if the transmission line is terminated in its characteristic impedance at the input and the amount of amplification is increased, oscillations will start. The frequency of oscillation will be controlled by the phase delay in the amplifier chain.

With this background we can now examine the actual functioning of the backward-wave oscillator tube. Figure 3-13 shows a cross section of the helix and a portion of the electron beam. The helix structure consists of a cylindrically-wound flat-wire tape; the electron beam is hollow and passes very close to the helix turns. The strong axial magnetic field focuses the electrons in the beam and allows movement only in the direction of the axis of the tube. The lines of force of the electric fields associated with an rf wave traveling along the helix are also shown in figure 3-13. Although these fields rotate around the helix at the velocity of light, the effective axial velocity is equal to the velocity of light times the ratio of the turn-to-turn spacing of the helix divided by its circumference. The axial electric fields will be strong between helix turns and very weak under the turns since electric fields cannot exist parallel to a conductor. The strong

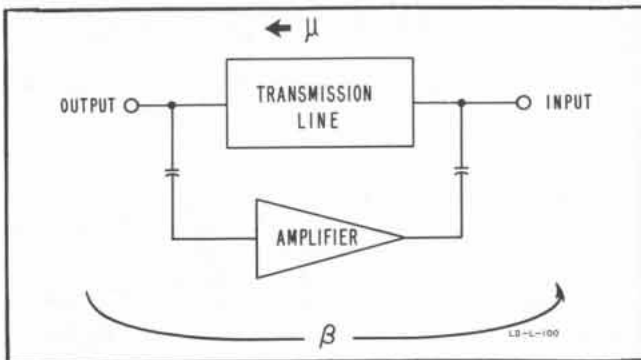

Figure 3-11. A Single Regenerative Loop

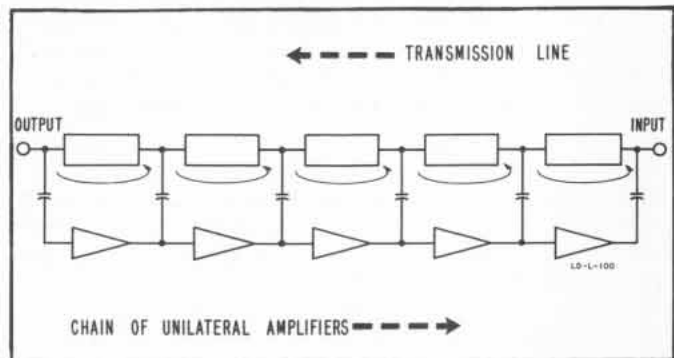

Figure 3-12. A Chain of Regenerative Loops

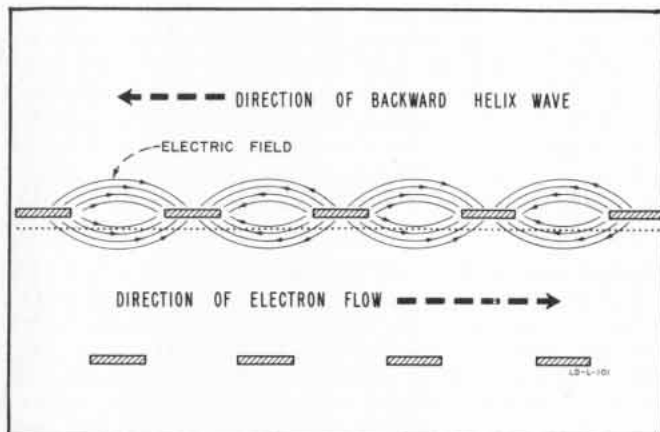

Figure 3-13. Cross Section of Helix Electron Beam and Helix Wave

effect of these fields between helix turns on the velocity of the electrons in the beam produces an interaction process which is represented by the capacitive coupling between the transmission line and the amplifier chain shown in figure 3-13. In this way, feedback loops are formed between the mid-points of adjacent helix gaps.

Although the concept of discrete feedback loops is a useful device for explanation, the backward-wave interaction is actually a continuous process. The maximum coupling between the helix wave and the beam will occur midway between gaps and gradually taper off to a minimum directly under the helix turns. One of these regenerative loop chains exists at each angular position around the helix. Each of these regenerative loop chains is independently coupled to the helix transmission line, so the net effect is a continuous amplification and feedback process occurring down the entire length of the tube.

The basic mechanism of amplification is a velocity modulation process which causes the electrons to bunch in the beam. Figure 3-14 shows the sinusoidal variations in amplitude of the electric field at the midpoint between helix turns. The phase relationship between the backward wave on the helix and the velocity of the electron beam is such that each specific portion of the electron beam will be affected by an electric field of the same phase as it passes successive gaps down the helix. Referring to figure 3-14, an electron at point A experiencing the decelerating effect of the field at the first gap in the helix will experience a continuous decelerating effect caused by fields of the same phase and direction of force as it proceeds down

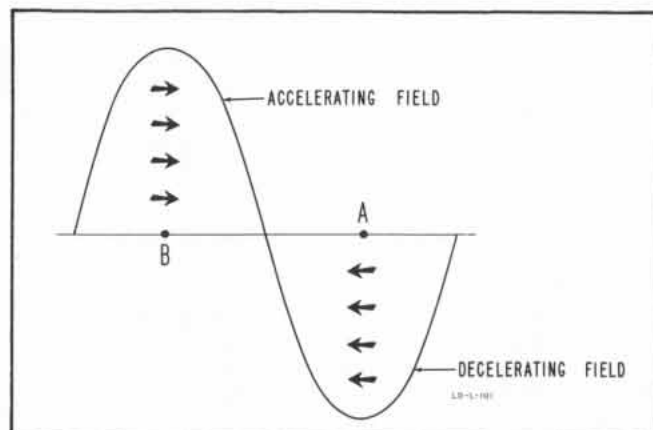

Figure 3-14. Axial Electric Field of Helix Wave which provides Velocity Modulation and Bunching of Electron Beam

the tube. In a like manner, an electron at point B will be continuously accelerated in its journey down the tube. In this way, some parts of the electron beam are slowed down while others are advanced and the net effect is a bunch formed at mid-point of figure 3-14 between the accelerating and decelerating fields. This situation is shown in figure 3-15. The spiral form of the bunched electron beam is due to velocity modulation which occurs at different rf phases at various angular positions around the spirally wound helix.

At this point it should be mentioned that the average electron velocity of the beam is slightly faster than the effective phase velocity of the amplifier chain. This means that the electron bunches will advance a quarter of a cycle as they approach the collector end of the tube, and thus encounter the decelerating effects of the electric field and give up a maximum amount of kinetic energy to the wave on the helix.

Figure 3-16 shows that the density of the electron bunches increases according to a sine-wave relationship; figure 3-16 shows the envelope of the bunching rather than instantaneous amplitudes since many rf cycles exist along the length of the backward-wave tube. The wave on the helix moves from right to left towards the gun end of the tube and gains amplitude between each turn according to the degree of electron bunching in the beam. In this way, the envelope of the wave on the helix shown in figure 3-16 is the integral of the bunching envelope so the maximum energy transfer from the beam to the wave on the helix occurs at the collector end of the tube.

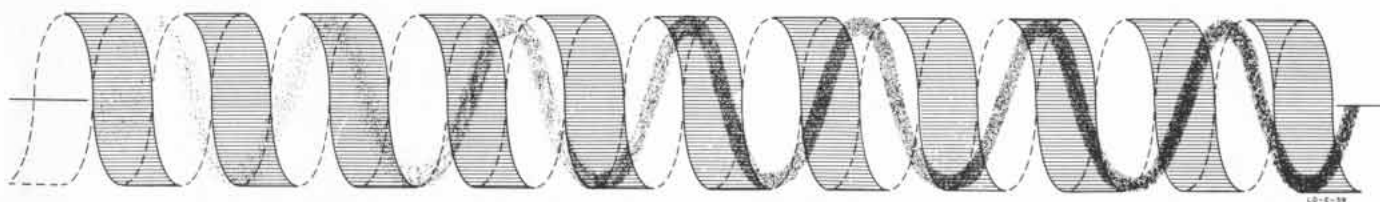

Figure 3-15. Helix Showing Bunching of Electron Beam

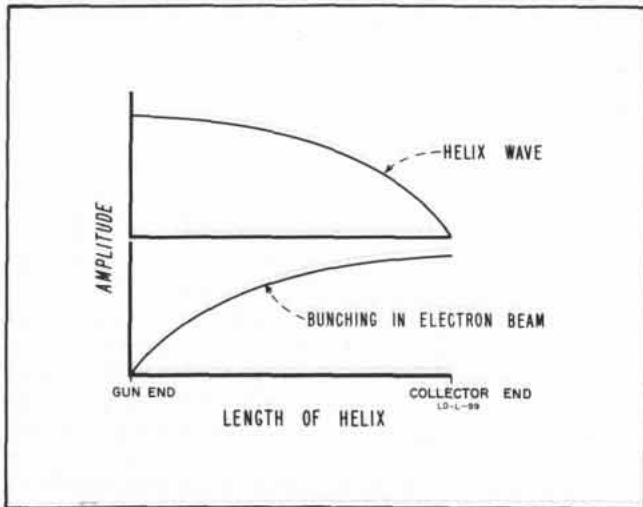

Figure 3-16. Relative Amplitude of the Helix Wave and the Degree of Electron Bunching along Helix

Now that a correspondence between the chain of lumped regenerative loops and the helix backward-wave oscillator tube has been established, it can be seen that if the velocity of the electron beam is varied, the phase delay around each of the regenerative loops will be changed and, if the electron beam current is high enough, the chain of regenerative loops will oscillate at a frequency where the phase delay of each loop is equal to one cycle.

Oscillations begin in the backward-wave oscillator in much the same manner as they begin in other oscillators. Noise waves are established on the helix from the shot noise coupled from the electron beam and from thermal energy developed in the termination at the input end of the tube. The waves traveling backward on the tube (to the left) velocity modulate the beam. Velocity modulation causes the electrons to bunch and in turn reinforce the wave that exists on the helix at the frequency where the single loop delay is equal to one cycle. In this way, oscillations are built up at a single frequency determined solely by the electron beam velocity which is a function of the cathode to helix voltage of the tube.

SECTION IV MAINTENANCE

4-1. GENERAL.

This section contains information on the maintenance and repair of the sweep oscillator. A suggested "quick check" procedure is given for verifying that an instrument is operating properly. These checks are made with the cabinet in place and will verify instrument performance for routine maintenance or incoming quality control checks. The operator can also use this procedure to check that his instrument is operating normally and is within specifications.

A troubleshooting chart is given which systematically leads the technician through the instrument and also indicates which adjustments must be rechecked after repairing any particular circuit.

A test procedure is included which covers adjustment of all circuits for optimum performance. Specifications for the 686C Sweep Oscillator are given in the front of this manual. The test procedures in this manual give additional tests and data for your convenience in analyzing a particular instrument. These extra checks and the data they contain, are not to be considered as specifications.

Standard, readily available components are used for manufacture of Φ instruments whenever possible. Your most convenient source for spare or replacement parts is your local Φ Sales Representative who maintains a parts stock for your convenience.

When ordering parts, please specify instrument model and serial number plus the component description and stock number appearing in the Table of Replaceable Parts (section V).

Your local Φ Sales Representative also maintains complete facilities and specially trained personnel to assist you with any engineering, application, test or repair problems you may have with Φ instruments.

4-2. GENERAL PRECAUTIONS.

A. HIGH VOLTAGE.

WARNING: Operating potentials as high as 3200 volts are present at certain points in the instrument. The power supplies are all regulated and are capable of delivering relatively high currents for short periods. Be alert at all times to danger points. Do not remove the red safety cover which covers most of the high potential circuits unless absolutely necessary. Remember that the instrument chassis is always grounded by the green grounding wire and NEMA 3-prong connector; do not defeat its purpose with a three-prong to two-prong adapter or by removing the ground pin.

B. MAGNET POWER SUPPLY CAUTION

The magnet power supply is isolated from the chassis and the rest of the instrument. This supply is a voltage doubler circuit which is directly connected to the power line. All filter capacitor cans and/or terminals in the magnet power supply are thus part of the ac power system. Accidental shorts from parts of the circuit which are connected to the ungrounded side of the power line to the grounded instrument chassis will severely damage the parts before the fuses can blow. Care has been taken in design layout to minimize exposed parts which are connected to the ungrounded conductor (black power cord lead).

Silicon Rectifiers are used in the magnet supply. Because of the very low forward resistance characteristic of these units, they will be instantly destroyed if accidentally short-circuited. Be careful when making voltage measurements not to let the probe slip and short-circuit the voltage doubler circuit.

Voltage measurements in this supply, other than ripple measurements, should be made with an insulated case voltmeter. Electronic voltmeters such as the Φ Model 410B and 400D have the ground terminal connected to the instrument chassis and cabinet which is in turn grounded by the green grounding wire in the power cable. Accidentally connecting the meter input ground conductor to the ungrounded power conductor will short out the power source through the NEMA ground on the voltmeter chassis. Low level ac ripple measurements must be made with caution. Paragraph 4-7 tells how they can be made.

C. RF OUTPUT CAUTION

Never disassemble the rf cable and connector. The two tube rf output cable and connector are replaced as a unit. Assembling the cable and connector is difficult, and improper assembly may cause a high swr. In addition, the rf output coaxial cable is directly connected to the two tube helix and can have up to 2500 volts dc on it. A capacitor between the cable center conductor and the center pin of the X-Band cover flange protects personnel from the high dc voltage.

D. NEON LAMPS

Neon voltage dividers used as coupling elements in dc coupled circuits are aged, polarized, and selected for correct voltage drop. Refer to paragraph 4-18 for details before replacing any of these lamps.

E. OSCILLOSCOPE

With application of a positive external signal at the horizontal input of an oscilloscope, some oscilloscopes sweep from right to left, others from left to right. The illustrations in this manual show the oscilloscope horizontal sweeps going from right to left. Thus when using an oscilloscope that sweeps from left to right

the mirror image of the illustration will give the proper perspective.

F. BWO CATHODE CURRENT

Frequency calibration is slightly affected by bwo cathode current. Therefore to obtain best accuracy: 1) operate with cathode current initially set at value and frequency marked on meter plate; 2) make all adjustments with rated cathode current.

4-3. AIR FILTER.

The air filter is located at the rear of the instrument cabinet. Inspect the filter frequently and clean whenever any appreciable amount of dirt has been picked up. Proper attention to maintaining a clean filter will result in longer tube and component life.

Clean filter by washing in a warm water and detergent solution. Before re-installing, recoat the filter with a suitable air filter oil to increase its dirt-holding ability. Air filter oil can be obtained at most heating supply stores or may be obtained through your  Sales Representative.



4-4. CABINET REMOVAL.

The cabinet can be removed from the instrument as follows:









- 1) Remove back cover (remove four Allen screws).
- 2) Tilt the instrument over on its back. Rest the instrument on a board at least one inch thick to avoid crushing the strain feed-through insulator and the power cord.
- 3) Loosen the two set screws in the bottom of the front panel bezel. These screws clamp the front panel in the bezel.
- 4) Lift cabinet off of instrument.
- 5) To re-install the instrument in the cabinet perform the above steps in a reverse manner.

4-5. MAINTENANCE TEST EQUIPMENT REQUIRED.

The following test equipment is recommended for the complete adjustment and repair of this instrument:

- 1) Dc vtvm, accurate within $\pm 3\%$, 120 megohms input impedance, such as the  Model 410B. A dc vtvm, accurate within $\pm 1\%$, 200 megohms input impedance, such as the  Model 412A.
- 2)  Model 459A dc resistive voltage divider probe for use with the 410B vtvm. The probe multiplies meter readings 100:1 with a rated accuracy of $\pm 5\%$. The probe input impedance is 12,000 megohms. An overall accuracy of 2 or 3% is desirable for these tests. Thus the accuracy of the probe and multiplier combination should be measured. Rather than trying to calibrate the 410B with the probe, the meter alone

should be accurately calibrated and the percent error introduced by the probe should be measured. Then, readings made with the probe can be modified according to the percent error of the probe. This error is constant for all ranges of the meter.

- 3) Ac vtvm, accurate within $\pm 2\%$ of full scale, 3 megohms or more, sensitivity of 0.001 volt full scale.  Model 400D/H/L or  Model 403A Transistorized AC VTVM is recommended.
- 4) Insulated case 5,000 ohms per volt or more, rectifier type ac voltmeter. The instrument should be freshly calibrated to better than 2% at 6 to 7 volts ac 60 cycles.
- 5)  Model 150A Oscilloscope with 151A Plug-In Preamplifier and Model AC-21A Probe. The probe has an input impedance of 10 megohms shunted by 10 pf and has a voltage division of 10:1.
- 6) One X-Band 90° elbow solid waveguide.
- 7) One six-inch length of flexible waveguide.
- 8) One  Model X382A Precision Waveguide Attenuator.
- 9) Three  Model X532A Frequency Meters.
- 10) One  Model X421A Waveguide Crystal Detector.
- 11) One  Model X487B Waveguide Thermistor Mount.
- 12)  Model 430C Microwave Power Meter.
- 13) One variable transformer continuously adjustable from 100 to 130 volts, 7-1/2 amperes capacity. The output voltage must be monitored with a meter accurate to within 1 volt.
- 14)  Model 523 series or 522B Electronic Counter.

4-6. QUICK CHECK PROCEDURE.

The following tests will quickly check the over-all performance of the sweep oscillator. All tests are made with the instrument in its cabinet. The tests are given in an order which will provide a minimum of changes in test set-ups.

The test set-ups shown are recommended because they have the required accuracy and use equipment which is generally available. If other equipment or methods are substituted, it is important to select components which have equal or greater accuracy. Otherwise, the error introduced by the measuring equipment may make the 686C appear not to meet specifications.

A. OUTPUT POWER ACROSS THE BAND

- 1) Set up equipment as shown in figure 4-1.
- 2) Adjust the X382A for 10 db attenuation.

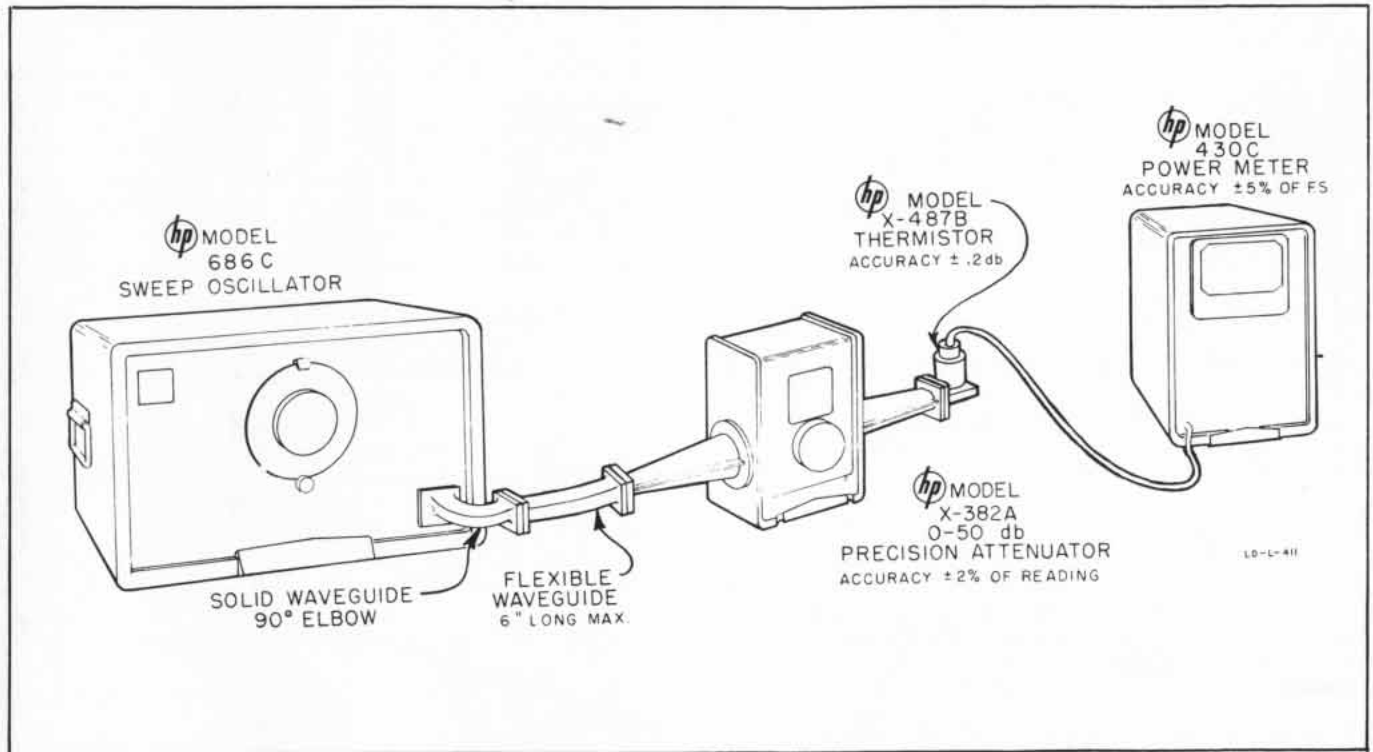

Figure 4-1. Measuring RF Output

- 3) Turn on equipment and adjust for rated cw output. (See figure 2-1 for recommended turn-on procedure.)
- 4) Allow 15 minutes for the Sweep Oscillator and the HP Model 430C Power Meter to stabilize.
- 5) Reduce power output to zero with the CATHODE CURRENT control and zero-set the power meter on the 3 milliwatt range.
- 6) Reset CATHODE CURRENT value at designated frequency.
- 7) Rotate the FREQUENCY dial slowly from one end of the band to the other and note power change. The change should not exceed ± 1.5 db for the full band. A thermistor mount with low swr must be used to obtain maximum accuracy.

NOTE

The power output can be severely reduced by use of excessive lengths of flexible waveguide or even short lengths which are not in good mechanical condition. Any discontinuities will cause reflections in the system. The attenuator must have very constant attenuation across the band. The X382 has excellent accuracy. It is also possible to use a 10 db directional coupler such as an HP Model X752C for an accurate attenuator.

B. FREQUENCY DIAL CALIBRATION

- 1) Connect a wavemeter and detector system to the sweep oscillator as shown in figure 4-2. The use of three wavemeters is a convenience, not a necessity. When one wavemeter is used, change its setting for each frequency check.
- 2) Adjust the Sweep Oscillator for rated cw output.
- 3) Tune the wavemeters to 8.2, 10 and 12.4 kmc. Rotate SWEEP SELECTOR to RECUR, Δ FREQUENCY to 14 and SWEEP RATE to 1k.
- 4) Rotate the FREQUENCY dial to the check points and watch for the wavemeter pip. Turn the FREQUENCY dial until the wavemeter pip has moved to the start of the rf sweep. Dial reading should agree within $\pm 1\%$ of the wavemeter reading.

NOTE

When more than one wavemeter is used, the wavemeter tuned to the low-frequency end may also resonate near the high-frequency end. If there are two pips at the high end, the true pip may be identified by "rocking" the high-end wavemeter: move its frequency-setting control back and forth a few degrees while watching the oscilloscope. The true high-frequency pip will move.

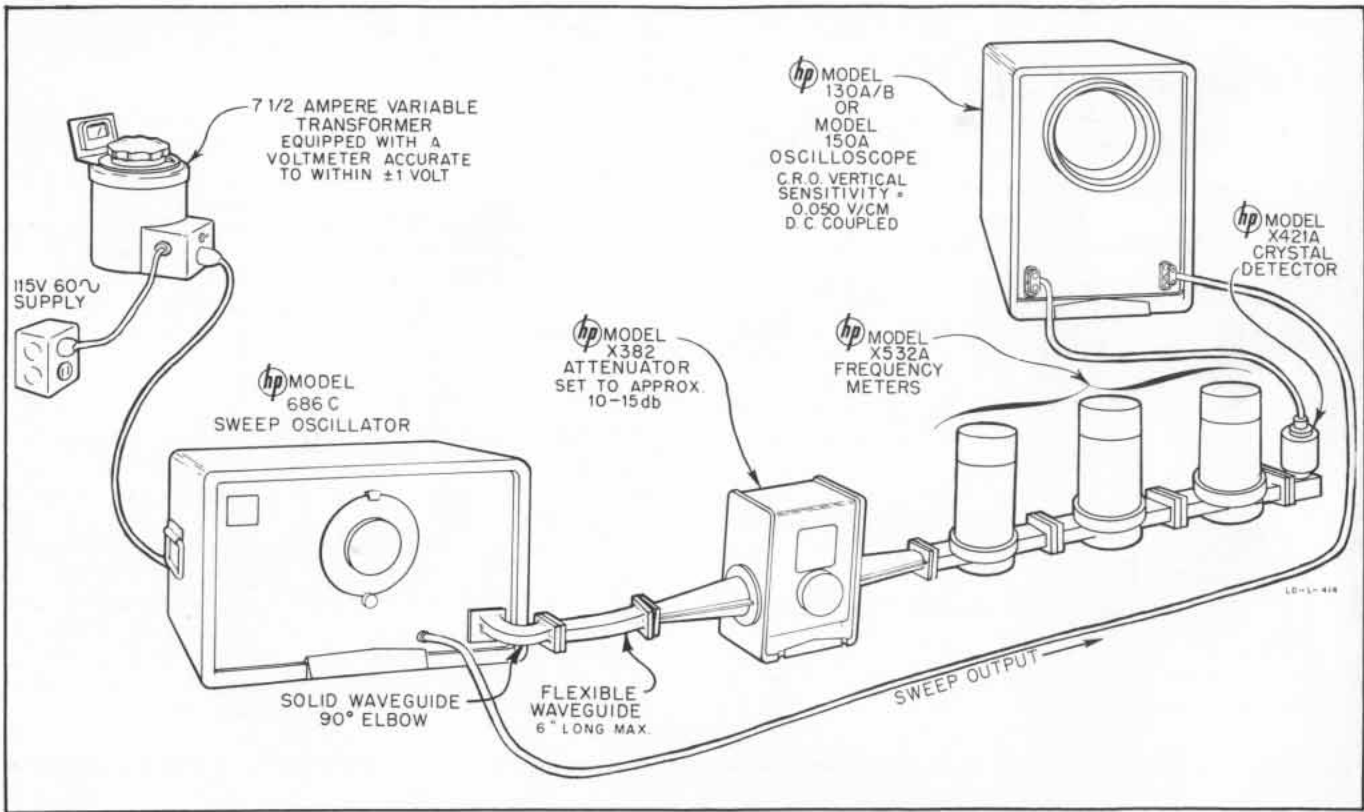

Figure 4-2. Checking Frequency Calibration and General Performance

5) Tune the wavemeter to other frequencies and check the dial reading.

C. SWEPT FREQUENCY OPERATION.

1) Set up the equipment as shown in figure 4-2. This procedure can be done with only one wavemeter. However, considerable time is saved if three wavemeters are used.

2) Set Sweep Oscillator to rated cw output and then rotate SWEEP SELECTOR switch to RECUR.

3) RF Sweep Length.

a. Rotate Δ FREQUENCY switch to 4.4K and the RF SWEEP RATE switch to 320K. Be sure the Δ FREQUENCY VERNIER is full clockwise in CAL position. Set the FREQUENCY dial to 12.4 kmc.

b. Adjust the wavemeters to 8.2, 10.3 and 12.4 kmc. The wavemeter pip should occur near the end of the sweep.

NOTE: $12.4 - 8.2 = 4.2 \text{ kmc}$

$$\frac{4.2 \text{ kmc}}{8 \text{ cm}} = 525 \text{ mc/cm}$$

Therefore 4.4 kmc will be represented by a trace 8.4 cm long, approximately.

c. Adjust the horizontal gain of the crountil the wavemeter pips at 8.2 and 12.4 kmc are exactly 8.0 cm apart.

d. The sweep length should be 8.4 cm, ± 0.84 cm. This represents:

$$4.4 \text{ kmc} + 440 \text{ mc} = \pm 10\%$$

4) Sweep Linearity

With the third wavemeter at 10.3 kmc, the pip should appear at the center of the screen at 4 cm, ± 0.2 cm (see figure 4-17). This checks the degree of matching between the exponential curve of helix voltage vs frequency characteristic of the bwo tube, compared to the exponential sweep generated by the sweep oscillator. With coincidence at three points, i.e., top, bottom, and middle, the curves should match at all other points.

5) Δ FREQUENCY Calibration

Rotate the RF SWEEP RATE switch counterclockwise to each position and observe the position of the wavemeter pips as in 3d and 4 above. The tolerance is ± 0.84 cm. This procedure verifies that the Δ FREQUENCY switch calibration is within specifications at its maximum setting.

If it is desired to check the Δ FREQUENCY switch at the other settings, set the RF SWEEP RATE switch at 32K and rotate the Δ FREQUENCY switch through each of its positions, measuring the Δ frequency with the wavemeter at each step and computing the error. For sweeps less than full band, the specification is +25%, -15% or ± 3 mc, whichever is greater. If the Δ frequency is within specifications for both procedures (with Δ FREQUENCY at 4.4K, through all positions of the RF SWEEP RATE switch, and with RF SWEEP

RATE at 32K, through all positions of Δ FREQUENCY) then the Δ FREQUENCY switch should be within specifications at all other settings.

D. TRIGGER CHECK

- 1) Set up equipment as shown in figure 4-2.
- 2) Rotate RF SWEEP RATE control to 3.2K.
- 3) Rotate Δ FREQUENCY control to 4.4K.
- 4) Rotate SWEEP SELECTOR to TRIG.
- 5) Push the MANUAL TRIG. button and observe rf sweep display on the cro screen. See specifications in subparagraph C3d and C4.
- 6) A positive 20-volt pulse (3 volt/usec or less rise time) to the EXT. TRIG. jack will also initiate a sweep.

E. FREQUENCY STABILITY WITH CHANGING LINE VOLTAGE

- 1) Set up equipment as shown in figure 4-2, with one wavemeter in the system.
- 2) Set the Δ FREQUENCY switch to 14 mc and the RF SWEEP RATE switch to 1K mc/sec.
- 3) Rotate the SWEEP SELECTOR to RECUR.
- 4) Set the power line voltage to 103 volts.
- 5) Adjust the sweep width to be 10 cm. Thus: 1 cm = 1.4 mc.
- 6) Adjust the rf output to 8.2 kmc. (This is the most critical frequency.) Tune one of the wavemeters to 8.2 kmc so that a pip will appear centered on the cro. Allow frequency to stabilize for about 2 minutes.
- 7) Increase the line voltage to 127 volts, wait two minutes and note the final drift of the wavemeter pip on the screen after the frequency drift has stabilized. Maximum change = 4 mc or about 2.8 cm on the oscilloscope.

F. MODULATION CHECKS

- 1) Set up equipment as shown in figure 4-2 without wavemeters in the system.
- 2) Adjust the oscilloscope for internal sweep, and sync. Sweep speed should be approximately .5 ms/cm.
- 3) Rotate SWEEP SELECTOR to OFF and AMPL. MOD. SELECTOR to INT.
- 4) Observe square wave symmetry as frequency is varied from 400 to 1200 cps. Symmetry is better than 40% - 60%. Verify frequency range by measuring period of one cycle: 2500 usec = 400 cps and 833 usec = 1200 cps.
- 5) Adjust oscilloscope sweep to free run.

6) Rotate the AMPL. MOD. SELECTOR switch to OFF. Set X382A to 10 db.

7) With the oscilloscope dc coupled, note the voltage level with the oscillator on cw. Adjust the deflection to 5 cm.

8) Switch AMPL. MOD. SELECTOR to INT. and note the amplitude of the square wave. The amplitude will be within 1 db or about 10% of the cw level. With 5 cm deflection on cw this difference will be less than 0.5 cm.

G. RESIDUAL FM

The following simplified test procedure is given for your convenience. A minimum of time and test equipment is required. However, this measurement method is valid only when all controls are set as given in the procedure. A method for checking residual FM under cw conditions is given in ϕ Application Note No. 1. This note describes a technique which requires considerable equipment; its use is not necessary to verify normal instrument operation. Application Note No. 1 is available from Hewlett-Packard Company or from your local ϕ Representative on request.

- 1) Set up equipment as shown in figure 4-2 with one wavemeter in the system.
- 2) Set output frequency to 8.2 kmc.
- 3) Adjust RF SWEEP RATE switch to 1K mc and Δ FREQUENCY switch to 14 mc. Thus with 10 cm deflection on cro, 1 cm = 1.4 mc and 0.2 cm = 280 kc.

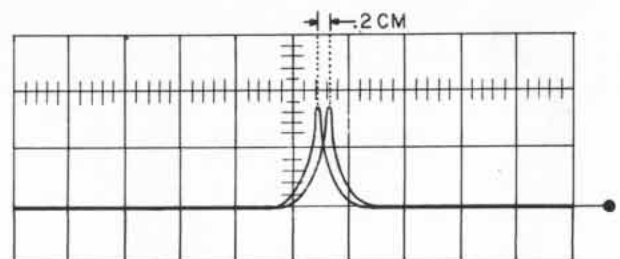

$$\begin{aligned} 2\delta F &= .2 \text{ CM P-P} \\ &= .2 \text{ CM} \cdot 1.4 \text{ MC/CM} \\ &= .280 \text{ MC} \\ \delta F &= 140 \text{ KC PEAK} \end{aligned}$$

RO

- 4) Observe jitter in wavemeter pip at 8.2 kmc. One half the distance between the pips is the peak residual FM. Residual FM will normally be less than 200 kc peak = 400 kc peak-to-peak = 0.280 cm.

NOTE

FM will be most pronounced at the low frequency and of the band and decreases at higher frequencies.

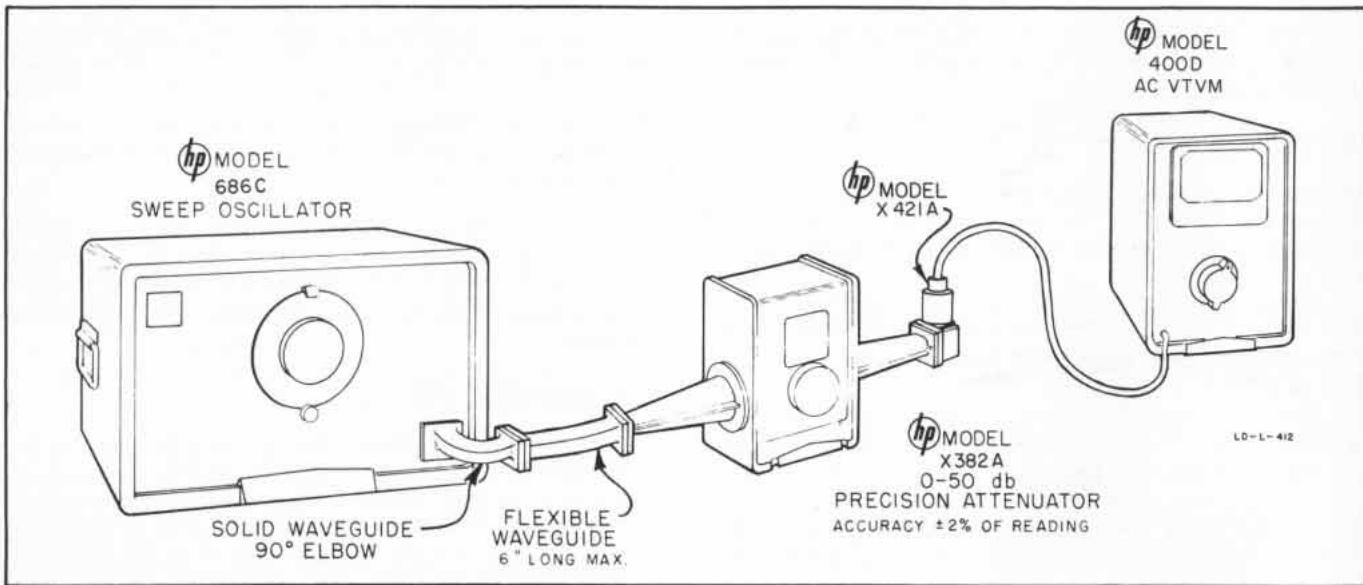

Figure 4-3. Setup for Measuring Residual AM

H. RESIDUAL AM

- 1) Connect equipment as shown in figure 4-3.
- 2) Adjust the Sweep Oscillator for rated cw output.
- 3) Switch to INT. square wave modulation.
- 4) Adjust the Model 382A attenuator to get a reading of -10 db on the 400D/H/L voltmeter (db_0).
- 5) Switch back to cw, and rotate the 400D/H/L switch to the -50 db position. Read db level (db_1).
- 6) The residual AM is equal to $(db_0 - db_1) + 8$ db.

NOTE

It can be shown that under the specified conditions of measurement (steps 1 through 5) (output voltage detected by a crystal detector operating in the square-law region of its characteristic; readings taken on an average-responding voltmeter) an 8-db factor is required to obtain the correct value of the residual AM.

This 8-db factor accounts for a) the crystal square-law characteristic and b) the difference between the average values and peak values of a square wave and a sine wave.

- 7) Residual AM should be 40 db or more below the cw level. Thus the value obtained in step 6 should be greater than 40 db: For example:

db_0	(400D reading, step 5)	-10 db
db_1	(400D reading, step 5)	- (-45 db)
		+35 db
		+8 db
	Residual AM	43 db

4-7. REGULATED MAGNET SUPPLY.

A. EQUIPMENT NEEDED

- 1) An HP Model 403A Transistorized AC VTVM or an HP Model 400D AC VTVM. If the 400D is used it must be equipped with a three-prong to two-prong adapter or a 1:1, 115-volt isolating transformer so that the instrument case can be made floating with respect to ground.
- 2) 7-1/2 ampere variable transformer equipped with voltmeter of 1% accuracy.

B. MEASUREMENT PROCEDURE

- 1) Set line voltage to 115 volts and adjust magnet current to 0.7 ampere as read on front panel meter using R30. Allow to heat 15 minutes before making final adjustment.

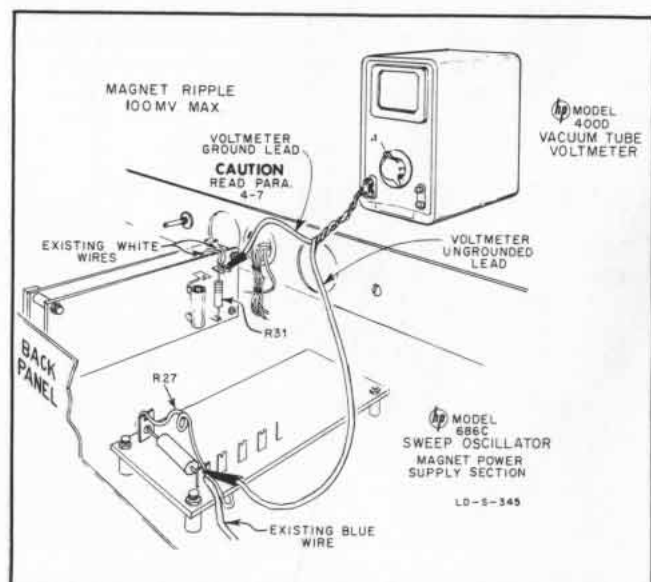

Figure 4-4. Measuring Magnet Circuit Ripple

- 2) Check Magnet Regulator action by dropping line voltage to 103 volts. Current should not vary more than 0.025 ampere.
- 3) Repeat with line voltage at 127 volts.
- 4) Use an isolated ac voltmeter to check ripple voltage. See CAUTION below. Connect voltmeter to upper end of R31 (white wire) and right hand end of R27 (blue wire).

The hum or ripple voltage across the magnet must be less than 100 millivolts with the line voltage varied over the range of 103 to 127 volts.

CAUTION

The magnet power supply uses a voltage-doubler circuit directly connected to the power line. When the power cord is inserted in a polarized three-wire outlet that is properly wired, approximately 150 volts dc and 6.3 volts ac appear between electrical ground and the end of R31 to which the white wires are connected. If the line cord is reversed, approximately 122 volts ac as well as the 150 volts dc will be present on the white lead which may give false ripple voltage measurements. Check cord polarity by measuring the voltage between the white-wire end of R31 and ground. Use a multimeter type ac voltmeter with a dc blocking capacitor in one lead; you should measure 6.3 volts ac and not 120 volts ac.

When checking the ripple voltage, the voltmeter case must be isolated from ground. Temporarily disconnect the voltmeter NEMA ground connector by using a two-prong adapter with the pigtail floating. Do not touch the voltmeter cabinet while making this check.

Poor regulation and excessive ripple are almost always due to weak tubes (V1 to V5) or noisy neon lamps (V6 through V11). First replace tubes, then try replacing the neon lamps. In the case where a neon lamp is noisy a good method for determining which lamp is at fault is to shunt a 470,000 ohm, 1/2 watt resistor across each lamp while watching for ripple indication on the 400D. If ripple decreases with the addition of the 470,000 shunt resistor, change that particular neon lamp.

4-8. -150 VOLT REGULATED SUPPLY.

- 1) Connect the 412A voltmeter from chassis to -150 volts at R129 (150K white wire). (See figure 4-5.) Adjust power line voltage to 115 volts.
- 2) Adjust R148 for exactly -150 volts dc.
- 3) Drop line voltage to 103 volts and watch for change in -150 volt level. There should be no visible change.
- 4) Raise line voltage to 127 volts and watch for a change. None should be noticeable on the ϕ Model 412A.

5) Connect the ϕ Model 400D or 403A ac voltmeter between the -150 volt bus and ground. The ripple voltage must be less than 3 mv over the range of 103 to 127 volts line.

6) Poor regulation and/or ripple are usually caused by weak tubes. Check by substituting for V107, V108, or V109.

4-9. 300 VOLT REGULATED SUPPLY.

This supply uses the -150 volt bus for a reference voltage. Therefore the -150 volt supply must be working perfectly and be accurately adjusted before the +300 volt supply is adjusted.

- 1) Connect the 412A between chassis and +300 volts at red wire, V106 Pin 1. (See figure 4-5).
- 2) Adjust the voltage to exactly +300 volts with R141.
- 3) Check the regulation by slowly varying the line voltage down to 103 volts and up to 127 volts. There should be no visible change on the 412A voltmeter.
- 4) Check the ripple voltage with the 400D or 403A voltmeter. The ripple should read less than 10 mv over a line voltage range of 103 to 127 volts.
- 5) Recheck -150 volt supply and reset if necessary, then reset +300 volt supply.

4-10. HELIX SUPPLY.

1) Check the Helix Regulator by measuring the voltage from V101 pin 1 to ground. Use the 410B dc vtvm with 100:1 multiplier probe. The voltage will vary from +400 volts when the FREQUENCY dial is at the low frequency end to +2,000 volts when the FREQUENCY dial is at the high end.

2) Adjust the FREQUENCY dial until the voltage is 1,000 volts. Slowly vary the line voltage from 103 to 127 volts. There should be no visible change on the voltmeter.

3) Reduce line voltage to 103 volts. Set Helix to 2,000 volts (FREQUENCY dial at high end). Measure voltage on collector (pin 7 of V102). The voltage must be greater than 2,050 volts. If not, replace V102.

4) Raise line voltage to 127 volts. Set Helix voltage to 400 volts (FREQUENCY dial at low end). Measure voltage on collector (pin 7 of V102). The voltage must be less than 2,600 volts.

5) TURN THE SWEEP OSCILLATOR POWER OFF. Disconnect the two tube high voltage connector. Connect four 100,000 ohm, 1 watt resistors in series and connect them from the two tube side of overload relay K103 to ground. Rotate the FREQUENCY dial to the low end. Rotate the CATHODE CURRENT control full counterclockwise.

6) Turn on the equipment and measure the voltage across the four 100K resistors. With 400 volts, 1 ma will flow through them.

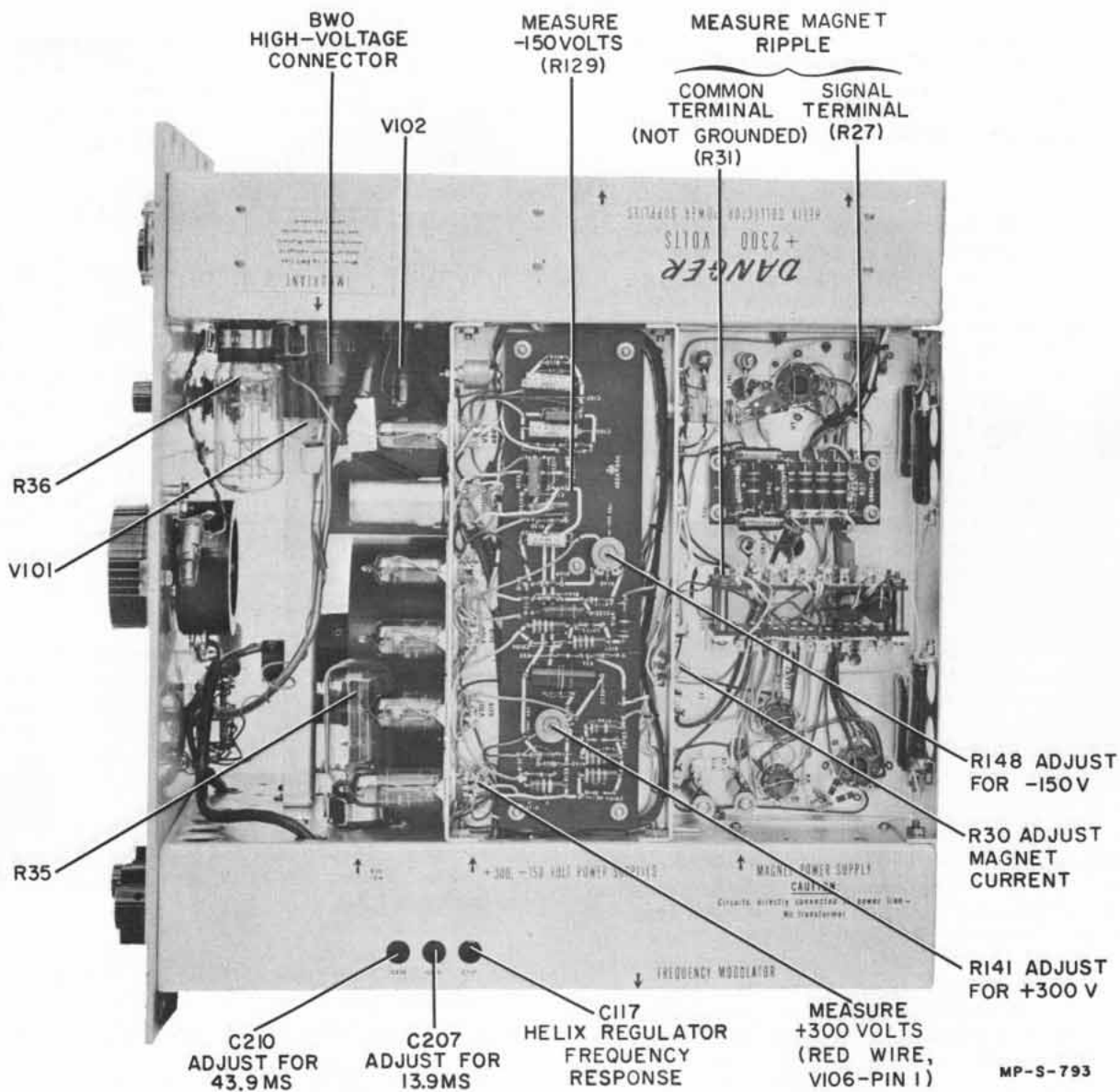

Figure 4-5. Model 686C Top View

7) Slowly rotate the FREQUENCY dial toward the high frequency end and watch the rising voltage across the resistors. When the voltage reaches 1,000 to 1,200 volts the overload relay should operate and cut off the high voltage circuits. This corresponds to 2.5 to 3 ma maximum current required to operate Helix Overload Relay K103.

8) Pad K103 if relay operates at too low a current. A 50,000 ohm resistor will increase current about 10%.

4-11. FILAMENT REGULATION.

The two, helix control circuits, and the sweep generator circuit are all operated from regulated filament supplies. The regulated filament supply circuits must be adjusted accurately, otherwise associated tubes and circuits will be affected drastically.

The voltage on the two tube filament is critical and will affect the life of the tube. The filament voltage is nominally 6.3 volts. When a new tube is installed be certain to verify that the voltage is adjusted to agree with the tube manufacturer's specifications furnished with the replacement tube. Do not allow the voltage to be more than 0.2 volt higher than rated even for a minute, as the filament will be damaged.

The best way to adjust the two tube filament voltage is to adjust the line voltage to 127 volts and then adjust the value of shunt pad resistor R39 (figure 4-20) until the voltage is at the safe limit, as specified by the manufacturer. The ballast tube (R36) will then hold filament voltage within 0.1 or 0.2 volt at lower line voltages.

CAUTION

BE CAREFUL WHEN MAKING CONNECTIONS. VERY HIGH VOLTAGES EXIST IN THIS AREA. BE CERTAIN THE EQUIPMENT IS OFF BEFORE CONNECTIONS ARE MADE OR BROKEN OR PADDING RESISTORS ARE CHANGED. USE INSULATED CLIPS TO AVOID ACCIDENTAL SHORT CIRCUITS.

When adjusting two tube filament voltage, first connect an accurate insulated-case ac voltmeter across the two filament shunt resistors. These resistors are located under the red safety cover and are identified in figure 4-16. The padding should be adjusted so that the filament voltage does not exceed the optimum value by more than 0.2 volt with the line voltage adjusted to 127 volts. The regulator should not allow the voltage to go more than 0.2 volt below the optimum value at 103 volts. When checking the voltage at the limits, allow the line voltage to remain at 103 or 127 volts for several minutes so that the ballast tube completely stabilizes. The padding resistors should have sufficient wattage rating. Use 2-watt carbon resistors down to 36 ohms and 5-watt wirewound resistors if under 36 ohms, or use parallel combinations of 2-watt carbon resistors greater than 36 ohms to get low values.

Quite often, malfunctioning of the sweep generator circuit can be traced to low or high filament voltage.

A filament voltage change affects tube contact potential due to the change in emission current. A change in contact potential will shift the gating point of Schmitt Trigger V201 and clamp point of Clamp Diode V204B.

To set the Helix Control Circuit and Sweep Circuit Filament Regulator, follow the same procedures as for the two filament regulator. Using an insulated-case voltmeter, measure the voltage across shunt resistor R32. (R32 is located on a long horizontal resistor board--see figure 4-16.) Voltage measured must not exceed 6.4 volts at 127-volt line or 6.1 volts at 103-volt line. Pad R32 as necessary to get proper range.

4-12. MEASUREMENT OF LINEAR SWEEP TIMES.

The following procedure is based on the use of an hp Model 523B electronic counter with facilities for time interval measurements. Corresponding controls can be located on other counters.

1) Measure the -150 volt and +300 volt supply voltages and set as described above. Be certain to set the -150 volt supply first.

2) Measure the sweep amplitude. The sawtooth should be 20 to 25 volts. If not, pad R212. However, this should only be done if V202 and the other tubes are known to be good. In addition, the regulated filament voltage must be the correct value.

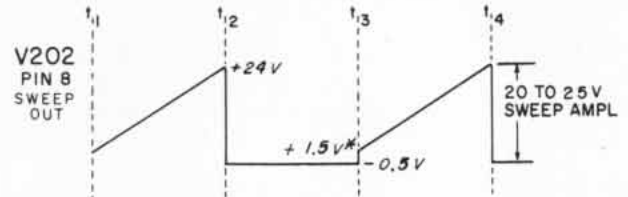

* VALUE VARIES WITH SETTING OF RF-SWEEP START VOLTAGE. [PARA. 4-14(7)]

RO

Figure 4-6. Sweep Out Voltage

3) Connect the 523B counter trigger to junction between R207 and R208 (see figure 4-15).

4) Set 523B input switch to COMMON.

5) Set 523B TRIGGER SLOPE START switch to (-) and STOP switch to (+).

6) Rotate 686C SWEEP SELECTOR switch to RECUR.

7) Rotate 686C Δ FREQUENCY switch to 4.4K, SWEEP RATE switch to 320K.

8) 523B front panel settings:

- a. FUNCTION SELECTOR to TIME INTERVAL.
- b. TIME UNIT to 10 kc.
- c. COM. SEP. switch to COM.

- d. Start TRIGGER SLOPE +.
 - e. Stop TRIGGER SLOPE -.
 - f. Start MULTIPLIER to dc x 10.
 - g. Stop MULTIPLIER to dc x 10.
 - h. Start TRIGGER LEVEL to -2.
 - i. Stop TRIGGER LEVEL to -2.
- 9) Counter should now measure a 14 ms sweep time. The limits are 13.4 to 14.4 ms with the line voltage at 115 volts. If out of specifications, adjust C207.
- 10) Rotate RF SWEEP RATE switch to 100K and read sweep time. The counter should read 42.1 to 45.7 ms with line voltage at 115 volts. If necessary, adjust C210 to get proper value.
- 11) Rotate RF SWEEP RATE to 32K. Read sweep time on counter. The limits are 134 to 144 ms. If out of specifications, check the sweep time with the SWEEP RATE switch set to 10K. The limits are 421 to 457 ms. If this sweep time is out of specification also, adjust R225 so that the sweep times corresponding to 32K and 10K are within specifications.
- 12) Repeat step 11 for sweep rates 3.2K and 1K. Specifications: 1.34 to 1.44 sec on 3.2K and 4.21 to 4.57 sec on 1K. If necessary, adjust R226 to get correct readings.
- 13) Repeat step 11 for sweep rates of 320 and 100. Specifications: 13.4 to 14.4 sec and 42.1 to 45.7 sec. If necessary, adjust R227 to get correct readings.
- 14) Measure sweep time for sweep rate at 32. Specifications: 1.34 to 14.4 sec. Generally no adjustment should be required. However, if specification cannot be met, the value of R232 can be changed slightly.
- 15) Connect the SWEEP OUTPUT to the vertical input of the oscilloscope. Set the SWEEP RATE switch to 320K and the Δ FREQUENCY switch to 4.4K. Adjust the oscilloscope controls to display a 20 to 25 volt sawtooth voltage of 14 ms duration.
- 16) Measure the sweep starting voltage which will appear as a vertical line at the beginning of the sawtooth. The "step" must be from 1 to 2 volts. If necessary, adjust R217 to obtain a level of 1.5 volts. Final adjustment is made when making the rf sweep adjustments (paragraph 4-14, step 7).

4-13. REPLACEMENT OF BWO TUBE AND CALIBRATION PROCEDURE.

Always handle the bwo tube with extreme care. The tube is very expensive and can be damaged by improper handling. The tube never should be removed from the capsule for any reason. Read all the removal and installation instructions before proceeding.

Handle the old tube as carefully as a new tube when the old tube is to be returned for warranty adjustment. Follow shipping instructions carefully since no allowance will be made on a tube which is broken when it reaches the manufacturer.

A. REMOVING THE BWO TUBE

- 1) Disconnect power from the instrument and remove the cabinet.
- 2) Disconnect the bwo grid leads.
- 3) Disconnect the bwo tube multi-conductor high-voltage cable connector from its mating receptacle located at the left hand side of the instrument, as seen from the front.
- 4) Remove the waveguide output flange and mounting plate by removing the two phillips head screws at each side on the front panel. Remove the flange from its rear mounting plate. Be careful to save the screws and plate. Do not disconnect the coaxial cable at the flange or at the bwo tube. Damage to the bwo output cable can result.
- 5) Using a #10 Allen wrench mounted in a driver-handle 8 to 10 inches long, unscrew the two #10 Allen screws at the front and rear of the magnet castings 1/2 inch. The front and rear screws are accessible from the top and right side of the instrument (see figure 4-9).
- 6) Carefully slip the capsule out from the rear. Feed the high-voltage cable and connector through the magnet core.
- 7) Follow the bwo tube "Warranty Claim and Replacement" page instructions. Pack the encapsulated bwo tube, output coaxial cable and waveguide output flange as directed, to insure safe arrival at the manufacturer's factory.

B. INSTALLATION OF A NEW BWO TUBE

- 1) Carefully feed the multi-conductor high-voltage connector through the rear of the magnet towards the front panel. The #10 Allen screws at the ends of the magnet should be backed out 1/2 inch so as to not catch on the connector.
- 2) Before the bwo tube is fully inside the magnet, thread the waveguide output flange through the large hole on the left-hand side (as seen from the rear of the instrument.)
- 3) The bwo tube should be installed so that the rear of the capsule is flush with fan housing (approximately 3-3/8 inches from magnet support bracket). The output fitting should be pointing downward to the left at a 45° angle (see figure 4-8).
- 4) Tighten the two rear #10 Allen screws so the capsule is accurately centered in the magnet hole.

NOTE

The capsule is supported at three points which are 120° apart. One is a spring-loaded ball and the other points are the two #10 Allen screws. By carefully adjusting the two screws the capsule can be firmly supported and accurately centered (see figure 4-9).

- 5) Repeat the process with the front two screws. It is not possible to exactly center the capsule by eye with the front screws. However, it is necessary to

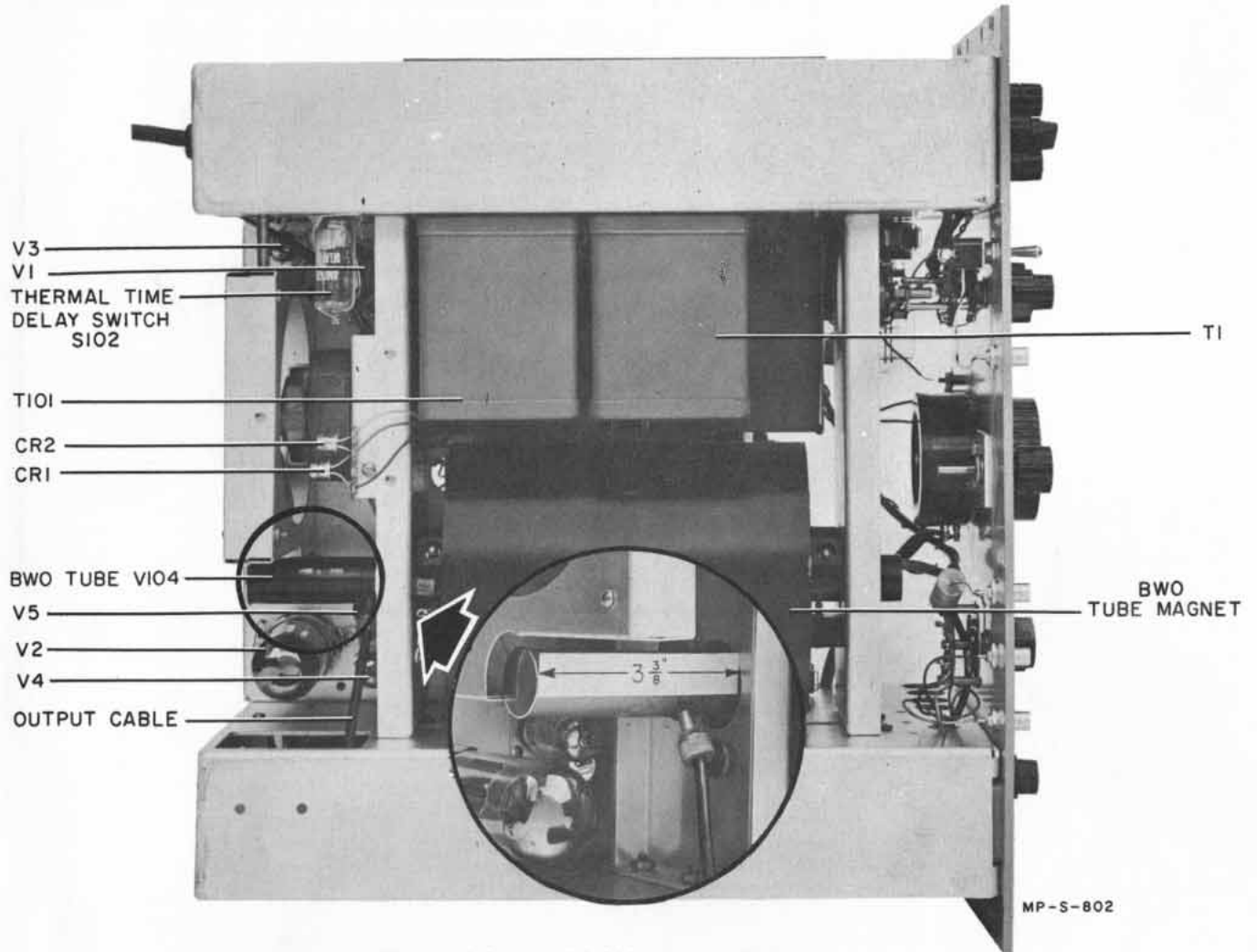

Figure 4-7. Model 686 Bottom View

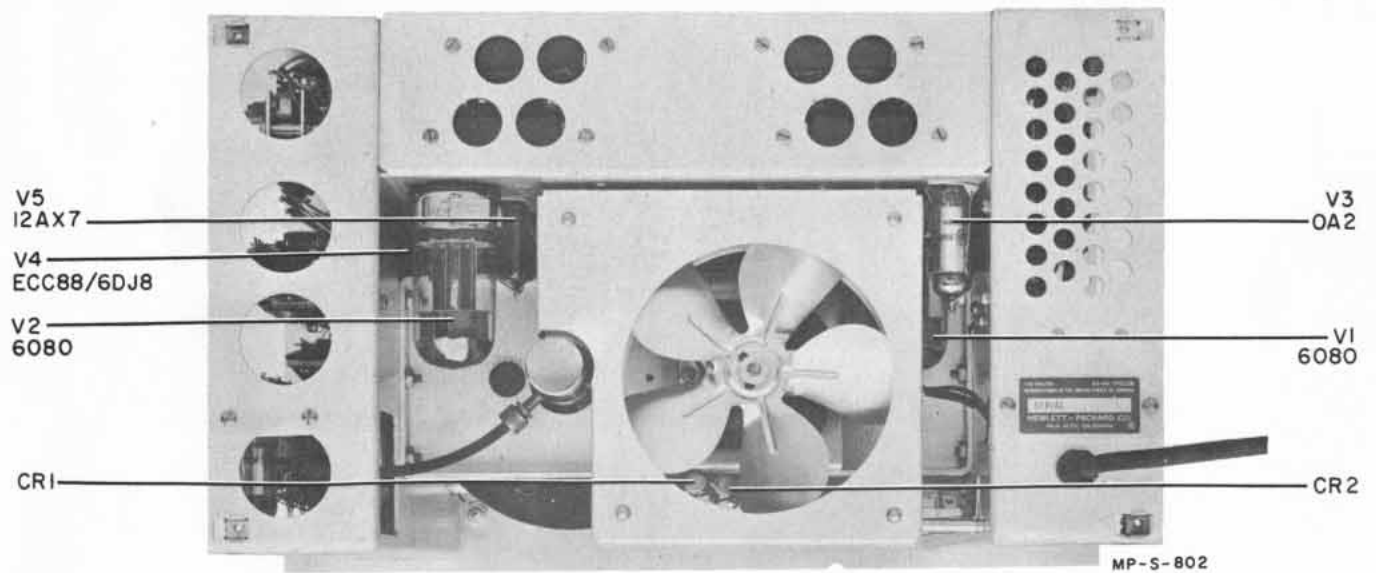

Figure 4-8. Model 686C Rear View

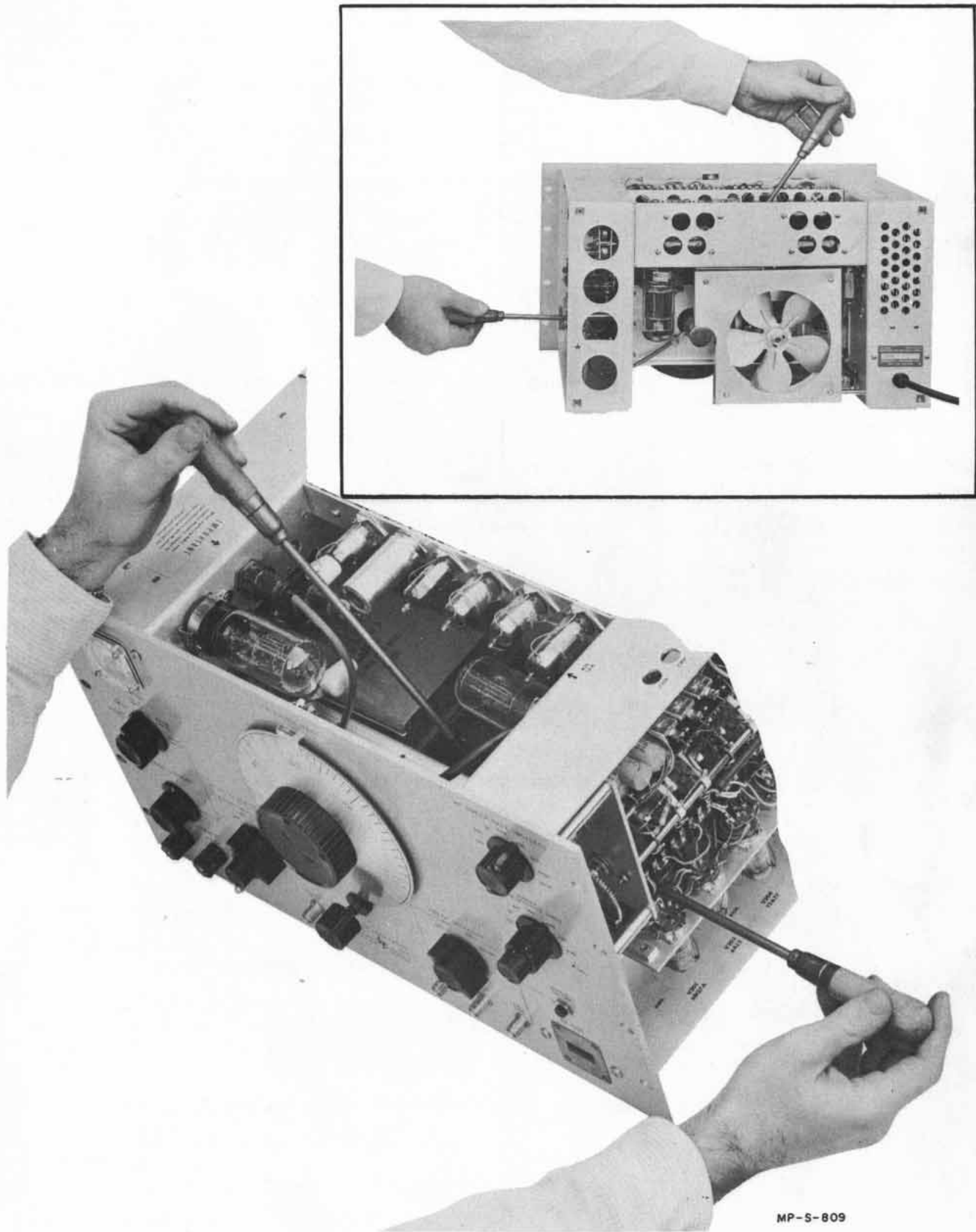

Figure 4-9. Positioning the BWO Tube at Front and Rear of Magnet

be as close as possible before a final electrical adjustment is attempted (see figure 4-9).

6) Mount the waveguide output flange at the rear of the front panel. Mount the new current plate on the meter.

7) Reconnect the high-voltage connector and grid connector.

8) Recheck the mechanical positioning of the bwo tube in the rear. If necessary, readjust the #10 Allen set screws to accurately center the capsule in the hole.

9) Set front panel controls as follows:

CATHODE CURRENT control extreme ccw
AMPL. MOD. SELECTOR OFF
SWEEP SELECTOR RECUR
 Δ FREQUENCY 140
RF SWEEP RATE 3.2K
CURRENT SELECTOR CATH.
RF DIAL 10.0 kmc
RF LEVELER OFF

10) Refer to Filament Regulator adjustment instructions in paragraph 4-11. Connect an accurate ac voltmeter with an insulated case to the bwo tube filament circuit.

11) Turn on power to the sweep oscillator and adjust the line voltage to 127 volts. Carefully watch the bwo filament voltage for 2 minutes. If the voltage exceeds the rated voltage by more than 0.2 volt, immediately turn the instrument off and readjust the value of the padding resistors (figure 4-6).

12) After accurately setting the filament voltage at 127 volts line, reduce the line voltage to 115 volts and turn off the instrument.

13) Insert two insulated #10 Allen drivers with approximately 8-inch long handles into the two front positioning screws.

WARNING

Wrap the shafts with insulating tape to avoid shorting out adjacent circuitry.

14) Turn on instrument. After two minutes, adjust CATHODE CURRENT control to obtain 1 ma CATHODE current.

15) Rotate CURRENT selector switch to HELIX and read the helix current. Adjust the position of the bwo capsule by simultaneously turning the two #10 Allen screws. Position the tube for minimum helix current.

16) Increase the CATHODE current control until cathode current is value marked on meter plate. Again read helix current and position tube for minimum current. Helix current must always be less than 3 ma with CATHODE current adjusted to rated value and at any output frequency.

17) Adjust dc level R332 to give 1 ma more than rated cathode current with CATHODE CURRENT control set

full clockwise. See paragraph 4-16 for adjustment procedure. Return CATHODE CURRENT control to setting which gives rated current.

18) Check frequency calibration.

C. FREQUENCY CALIBRATION

1) Set up test equipment as in figure 4-2. If desired, one wavemeter can be used instead of three.

2) Turn FREQUENCY dial to 8.2 kmc cw output, and adjust wavemeter to 8.2 kmc. If necessary, adjust R132 to make dial setting agree with wavemeter.

3) Turn FREQUENCY dial to 12.4 kmc and set wavemeter to 12.4 kmc. Adjust R135 to bring output frequency into agreement with the wavemeter.

4) Repeat these two checks at 8.2 and 12.4 kmc and refine the adjustments.

5) Adjust value of R234 if necessary, to make 10.0 kmc track.

6) Adjust sweep oscillator to sweep the full band and set up the three wavemeters at 8.2, 10.3 and 12.4 kmc. Check sweep linearity as described under Sweep Frequency Operation in paragraph 4-5c. If linearity is not within specifications, refer to paragraph 4-14 RF Sweep Linearity.

D. OUTPUT POWER CHECK

Check power output across the band as described, in paragraph 4-5a. Inability to get full power at some frequencies or excessive power change vs frequency when operating into a matched load is due to a defective bwo tube. Be certain that an apparent excessive power change is not in part due to mismatch in the power measuring equipment. Critical points in the band should be checked with a tunable load in the system. The ϕ Model X870A Slide Screw Tuner is recommended for tuning the system.

4-14. RF SWEEP LINEARITY.

NOTE: Allow instrument to operate at least 1/2 hour before making adjustments.

1) Set up test equipment as in figure 4-2. This procedure can be performed with one wavemeter. However, when three wavemeters are used, considerable time is saved.

2) Set the wavemeters to 8.2, 10.3 and 12.4 kmc.

3) Turn the RF SWEEP RATE to 100K.

4) Turn the Δ FREQUENCY to 4.4K.

5) Adjust the vernier on horizontal input sensitivity control of oscilloscope so that the sweep is 8.4 cm.

6) Adjust R244 (rf sweep linearity) and R246 (rf sweep expansion). See figure 4-16 to obtain a linear display of the full band (8.2 to 12.4 kmc).

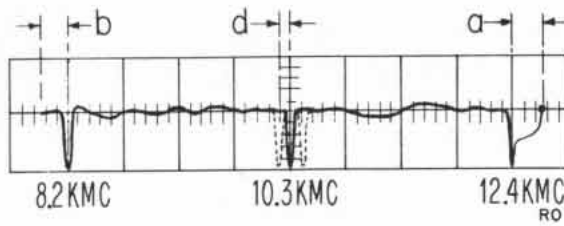

Figure 4-10. Calibration Pips on CRO Sweep (Linearity)

NOTE: R244 and R246 interact (see figure 4-10).

7) Adjust oscilloscope horizontal gain so that rf band 8.2 cm to 12.4 kmc = 8 cm.

a = .5 cm (adjust with R217)

b = must be within .2 cm to .9 cm (adjust R246)

d = ±2 cm (adjust R244 and R246 interact)

8) Turn RF SWEEP RATE to 320K.

9) Adjust R245 to bring b to .4 cm (Spec: .2-.9 cm).

10) Adjust length of X-band with vernier of horizontal cro amplifier to 8 cm (see figure 4-10).

11) Check linearity d within ±2 cm. If linearity d is not within the specifications, correct the error with R244, and recheck all previously adjusted positions.

12) Check linearity with RF SWEEP RATE at 100K.

NOTE

If the length of the X-band trace (8.2 to 12.4 kmc) has been adjusted to 8 cm it is practical to read linearity (d) directly with RF SWEEP RATE on the 320K to 3.2K positions. For the slower sweep rates (RF SWEEP RATE on the 3.2K to 32 positions) probably it will be more practical to calculate linearity (d) and sweep (b). Record (in cm) the positions of the 12.4 kmc, 10.3 and 8.2 wavemeter pips and the end of the sweep. Determine linearity and sweep length, and calculate the error. For example, with a trace such as that shown in figure 4-11A, since the sweep is decreasing from the High-frequency end the position of the 12.4 kmc pip would be recorded at 0 cm, the 10.3 pip at 4.2 cm, the 8.2 pip at 8.4 cm, and the end of the sweep at 9 cm.

To determine whether the linearity (d) is within specifications:

$$\% \text{ error} = \frac{P_{cf} - 0.5L}{0.5L} \times 100$$

where P_{cf} = position of center frequency pip (distance in cm from start of sweep)

0.5L = X-band midpoint in cm

L = X-band length in cm

(distance in cm between end pips)

For the sweep shown in figure 4-11A:

$$P_{cf} = \text{position in cm of 10.3 pip} = 4.2 \text{ cm}$$

$$L = 8.4 \text{ cm (8.2 kmc pip position} - 0 \text{ cm}$$

$$\text{(12.4 kmc pip position)} = 8.4 \text{ cm}$$

$$0.5L = 4.2 \text{ cm}$$

$$\% \text{ error} = \frac{4.4 \text{ cm} - 4.2 \text{ cm}}{4.2 \text{ cm}} \times 100 = 4.8\%$$

Linearity specification: band center frequency position in cm shall be within ±5% of band midpoint in cm.

Thus the sweep shown in figure 4-11A meets the linearity specification.

To determine whether the sweep length (b) is within specifications:

$$\% \text{ error} = \frac{L_a - L_d}{L_d} \times 100$$

where L_a = actual sweep length in cm

L_d = desired sweep length in cm

$$L_d = \frac{AF}{X} \times L$$

where AF = A frequency in kmc

X = X-band width in kmc

L = X-band length in cm

(distance between end pips)

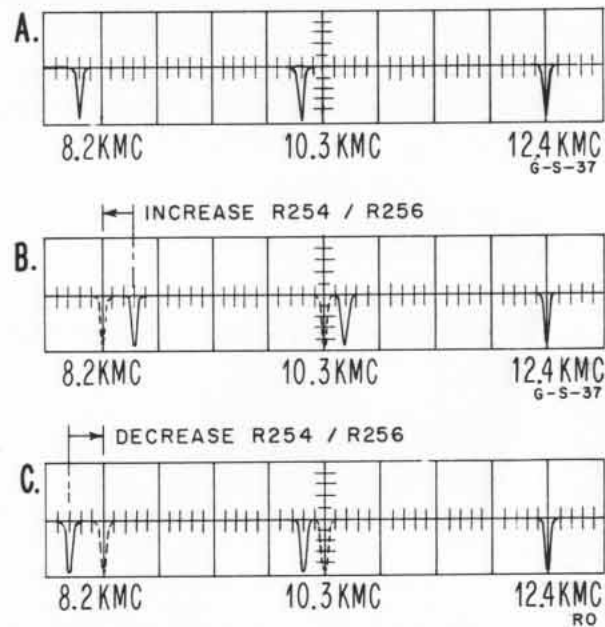

Figure 4-11. Calibration Pips on CRO Sweep (Length)

For the sweep shown in figure 4-11A:

$$L_a = 9 \text{ cm}$$

$$L_d = \frac{4.4 \text{ kmc}}{4.2 \text{ kmc}} \times 8.4 \text{ cm} = 4.4 \times 2.0 = 8.8 \text{ cm}$$

$$\% \text{ error} = \frac{9.0 \text{ cm} - 8.8 \text{ cm}}{8.8 \text{ cm}} \times 100 = +2.0\%$$

Sweep length specification: $\pm 10\%$ with Δ FREQUENCY set at 4.4K.

Thus the sweep shown in figure 4-11A meets the sweep length specifications.

13) Repeat step 8 for RF SWEEP Position at:

- 32K with R247
- 10K with R248
- 3.2K with R249
- 1K with R250
- 320 with R251

Do not change the setting of R244 without checking all previously adjusted positions.

14) Turn RF SWEEP RATE to 100.

15) Adjust the value of R254 so that RF SWEEP falls within specifications.

16) Rotate RF SWEEP RATE to 32, and adjust the value of R256 so that the RF SWEEP falls within specification.

4-15. SQUARE WAVE SYMMETRY ADJUST.

1) Set up 686C as shown in figure 4-2 (excluding the three wavemeters).

2) Set up 686C for cw operation as directed in figure 2-1, Turn-On Procedure and CW Operation.

3) Set front panel controls as follows:

SWEEP SELECTOR OFF
AMP. MOD. SELECTOR INT.

4) Rotate R302 (INT. SQ. WAVE FREQUENCY) fully counterclockwise (front panel).

5) While observing on oscilloscope, adjust Square Wave Symmetry Adj. R310 (figure 4-16) so the symmetry is better than 40 - 60%.

6) Check frequency range by measuring period of one cycle: 2500 usec = 400 cps and 833 usec = 1200 cps.

4-16. RF LEVELER AND REFERENCE ANODE VOLTAGE ADJUSTMENT.

The programming and reference anode voltages are supplied by the rf leveler circuit. When either re-focusing the bwo in the instrument or installing a new bwo tube, the rf leveler must be recalibrated and reference power level re-established.

A. SPECIAL TEST EQUIPMENT

An oscilloscope with a dual channel amplifier is needed for this procedure. The Φ Model 150A oscilloscope with 152B dual channel amplifier is recommended.

B. POWER LEVELER CIRCUIT CALIBRATION

1) Obtaining Reference Power Level

a. Set up 686C as shown in figure 4-14.

b. 686C front panel control settings:

SWEEP SELECTOR OFF
RF SWEEP RATE 100K
 Δ FREQUENCY 4.4K
VERNIER CAL
RF LEVELER OFF
AMPL. MOD. SELECTOR OFF
CURRENT SELECTOR CATHODE
CATHODE CURRENT max cw

c. With Balance Adj. R335 mid-range, adjust DC Adj. R332 (figure 4-13) to cathode current and at frequency indicated on meter face.

d. Turn SWEEP SELECTOR to RECUR.

e. Check FREQUENCY dial calibration at 8.2, 10.3 and 12.4 kmc. If recalibration is necessary, see paragraph 4-13c Frequency Calibration.

f. Rotate SWEEP SELECTOR to OFF.

g. Control settings for Φ Model 430C Power Meter:

POWER RANGE as needed
COEFF. NEG.
RES. 200 for Φ Model 477B
BIAS CURRENT . Setting needed for zero-set

h. Rotate the AMPL. MOD. SELECTOR to PULSE and zero-set the power meter.

i. Rotate CATHODE CURRENT control (front panel) R327 full clockwise.

j. Rotate FREQUENCY dial across the band and check that:

(1) Minimum power across the band is greater than 10 milliwatts (10 dbm). If minimum power is less than 10 milliwatts increase cathode current with DC Level Adj. R332.

(2) Power spread across the band is less than 3 db from high to low power point across the band. If power spread is too great, decrease cathode current slightly.

k. Readjust DC Level potentiometer R332 clockwise until minimum power point is greater than the specified 10 milliwatts (10 dbm). Record cathode current value at frequency at which minimum power point exists.

2) Obtaining crystal detector-attenuator power response:

- a. Rotate FREQUENCY dial to 8.2 kmc.
- b. Rotate CATHODE CURRENT control clockwise until 10 milliwatts (10 dbm) is obtained on the power meter.
- c. Rotate 686C SWEEP SELECTOR to RECUR. DO NOT MOVE THE CATHODE CURRENT control.
- d. Set the oscilloscope for dc coupling.
- e. Rotate the AMP. MOD. SELECTOR switch to PULSE.
- f. Draw a line with a grease pencil at some arbitrary point on the oscilloscope graticule. Set the oscilloscope beam at the rf reference line (see figure 4-12).
- g. Rotate the AMPL. MOD. SELECTOR to OFF.
- h. The point at which the oscilloscope electron beam deflects vertically from the reference line is the 10 milliwatt point at 8.2 kmc. Place a mark on the oscilloscope graticule as shown in figure 4-12.
- i. Repeat steps "a" through "h" at: 9, 10, 11, 12, 12.4 kmc.

NOTE: As each point is plotted on the oscilloscope, the oscilloscope HORIZ. POS. control must be rotated to move the power point to a new position on the graticule (see figure 4-12). The space between positioned plots on the oscilloscope graticule can easily be interpolated. With minimum oscillator power output a constant across the band, any indicated power variation is due to the characteristic of the crystal detector and attenuator used in the set-up. If not compensated for, these will introduce appreciable error.

- j. Connect points on the graph (see figure 4-12). This will give a permanent record of the power-line curve for the particular crystal and attenuator used.

3) Segment Adjustment Procedure

- a. With 686C set up as shown in figure 4-14, connect a test probe (not shown) from the anode of the bwo (see figure 4-16) to oscilloscope (channel B).
- b. 686 settings same as 1 b except:
 - (1) CATHODE CURRENT set to value and at frequency recorded in step 1k.
 - (2) SWEEP SELECTOR to RECUR.

NOTE; The RF SWEEP RATE, 320K position, should be roughly calibrated. See paragraph 4-14 RF SWEEP LINEARITY steps 1, 2, 3, and 8 through 10.

- c. Remove wavemeters from set up.

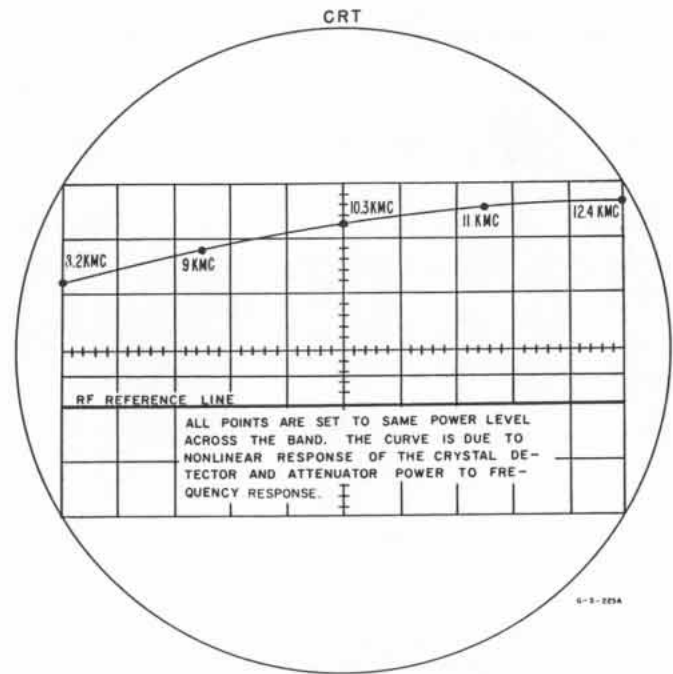
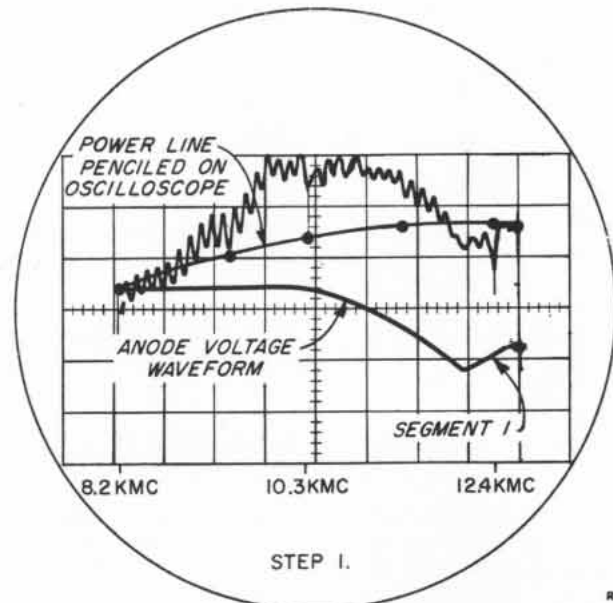

Figure 4-12. Crystal Detector-Attenuator Response Curve

WARNING

Be careful that there are no holes across the band due to either poor rf connections or impedance mismatches.

- d. RF LEVELER switch to ON.
- e. Level the coarse grain (figure 3-3) power variations of the rf power output presentation on the oscilloscope to the rf power line curve.
 - (1) Adjust Segment 1, R321, as shown:



(2) Adjust Segment 2, R324, as shown:

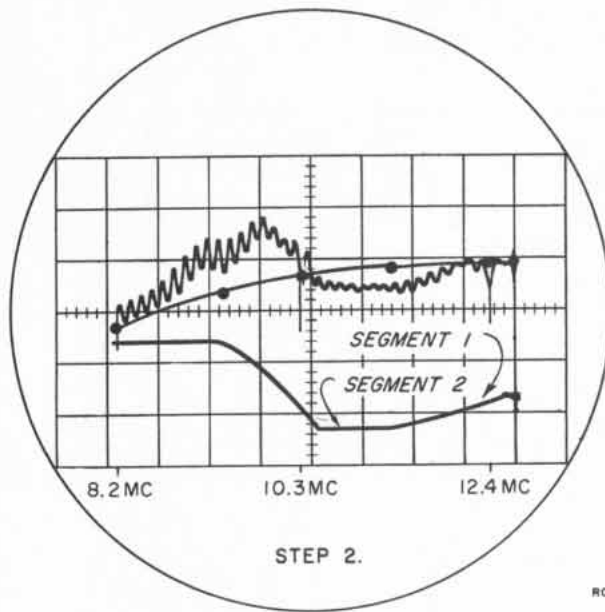

(3) Adjust Segment 3, R315 and Segment 4, R320 as shown. After making all four adjustments readjust Segments 1, 2, 3, and 4 as needed to obtain optimum leveling action.

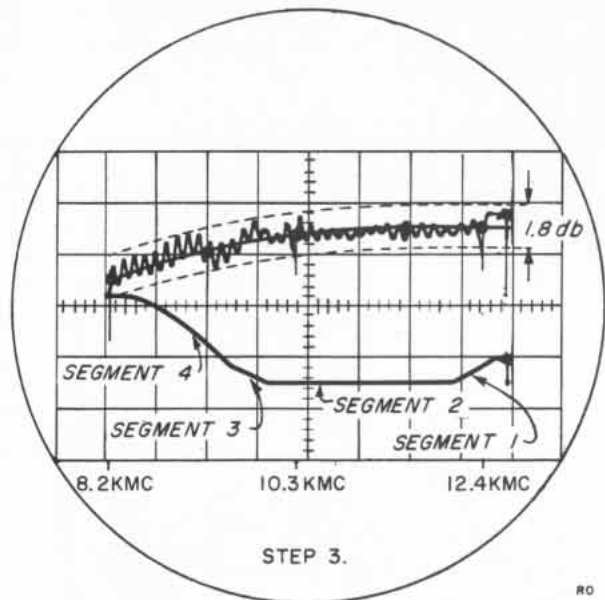

NOTE: There will be interaction between Segment 2 and Segment 3 since the height to which Segment 3 rises is a function of the parallel resistance of the plate load resistors R318 and R323, plus a section of R324. This interaction makes available a wide range of leveler shapes. There will also be a slight interaction between Segment 3 and Segment 4 adjustments and DC Level R332 adjustments.

f. Turn SWEEP SELECTOR to OFF.

- g. Check power variation across the band. The power spread across the band should be no more than ± 1.25 db. If out of specifications retouch segment potentiometers and dc level adjustments as needed.
- h. Turn FREQUENCY dial to low power point; RF LEVELER ON. With DC Level potentiometer R332 increase cathode current to 1 ma greater than the value recorded in B1K.
- i. Replace meter plate with new meter plate.
- j. With the RF LEVELER in the OFF position, set Balance R335 (figure 4-13) so that the Power Level is greater than 10 mw at low power point.

4-17. SERVICING THE SWEEP CIRCUITS.

A. VOLTAGES AND WAVESHAPES

The sweep circuit can be very difficult to service if definite conditions are not established. Figure 3-7 gives the typical wave shapes and actual dc levels of the complete sweeping system. These voltages and wave shapes are the same for any speed of sweep. If the sweep rate is high, these wave shapes may be directly observed on a dc coupled oscilloscope with a 10 megohm 10 pf probe such as an ϕ Model AC-21A. If this equipment is not available, it is possible to reduce the sweep rate to a very low value and use a dc vtvm such as an ϕ Model 410B with 122 megohms input impedance and accurately measure the upper and lower voltage limits.

With the sweep selector in the TRIG. position, the Schmitt Trigger V201 is biased to cut off the right hand half. The voltage conditions in the circuits will then be those at t_1 on the waveforms. In a like manner, by temporarily connecting a jumper from pin 7 of V201 to the -150 volt bus, the Schmitt Trigger can be locked in the sweeping state. The voltages will then be those at time t_2 .

NOTE

Upon first observation, the voltages shown in figures 3-7 and 4-25 across coupling and switching diode sections of V203 may appear to be in error. The voltages given indicate that the diodes are conducting when the plate is lightly negative with respect to the cathode. This is correct. Thermionic diodes have a contact potential developed between the plate and cathode of about 0.5 volt. For this reason, the diode actually starts to conduct when the plate is about -0.5 volt with respect to the cathode. The actual value of this voltage will change with cathode temperature. The heaters of critical tubes have regulated heater voltage to prevent a shift of sweep time calibration with changing line voltage. If the heater voltage is regulating at the wrong level the sweep circuit can be disabled. Paragraph 4-11 tells how to adjust filament regulation.

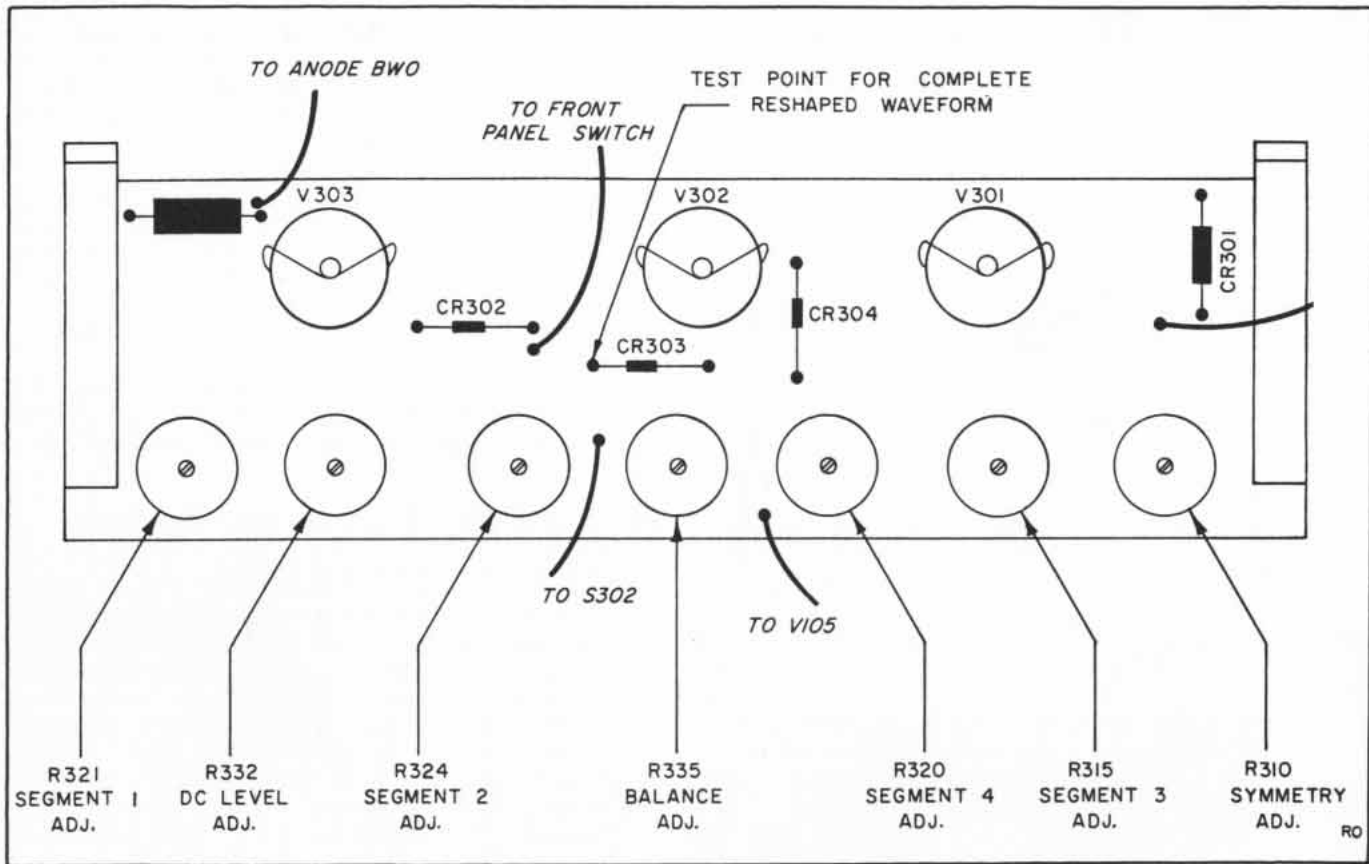

Figure 4-13. RF Leveler Circuit Board

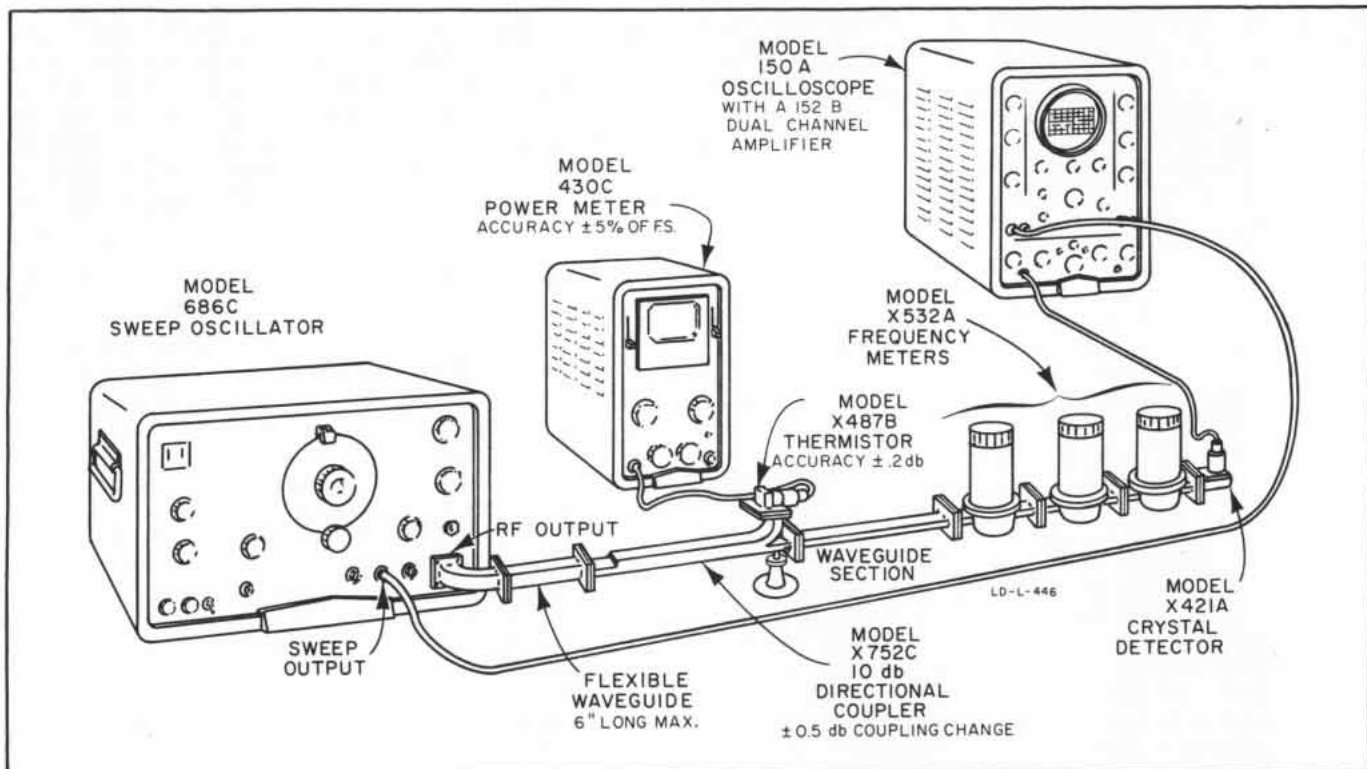

Figure 4-14. RF Leveler Calibration Setup

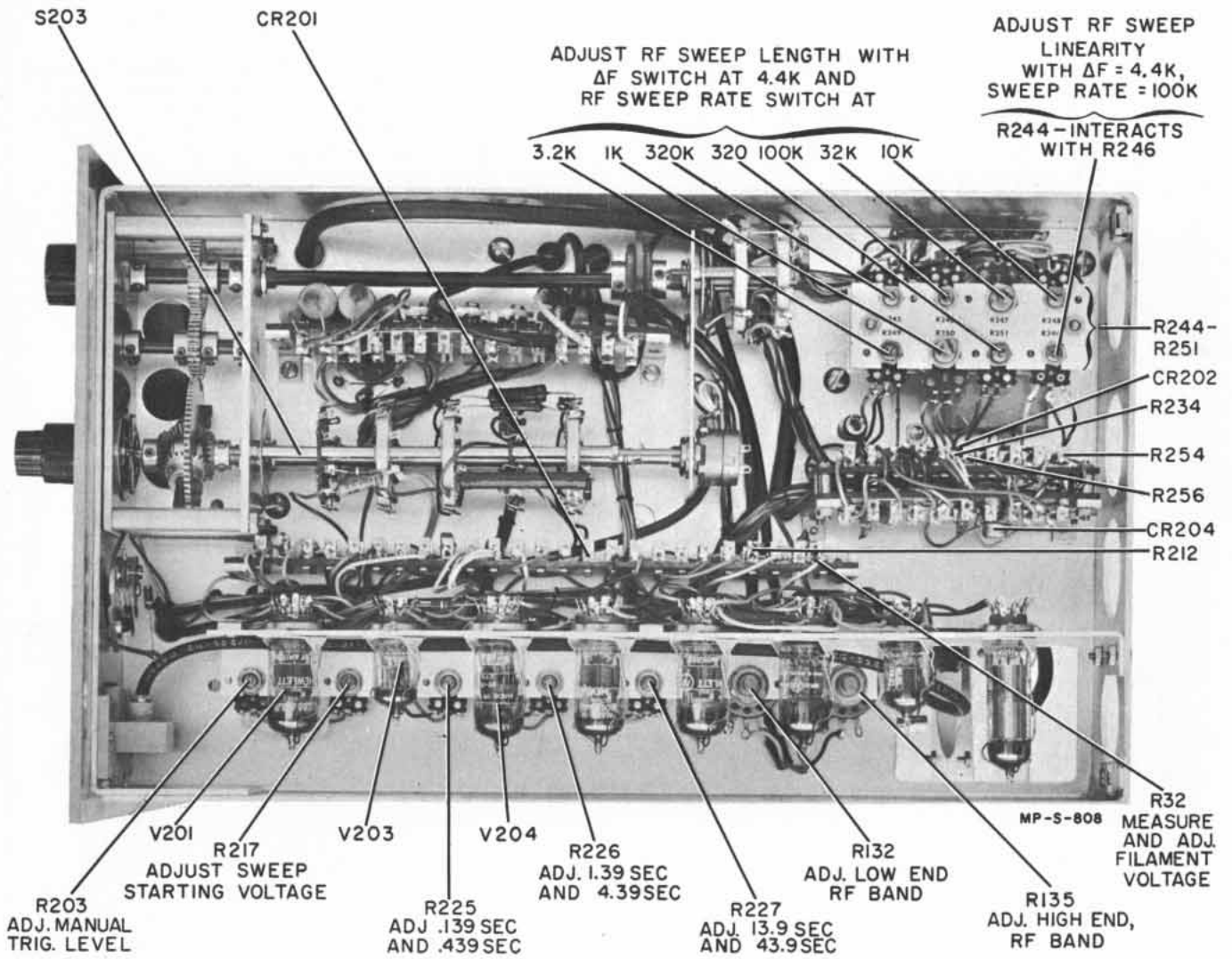

Figure 4-15. Model 686C Right Side View

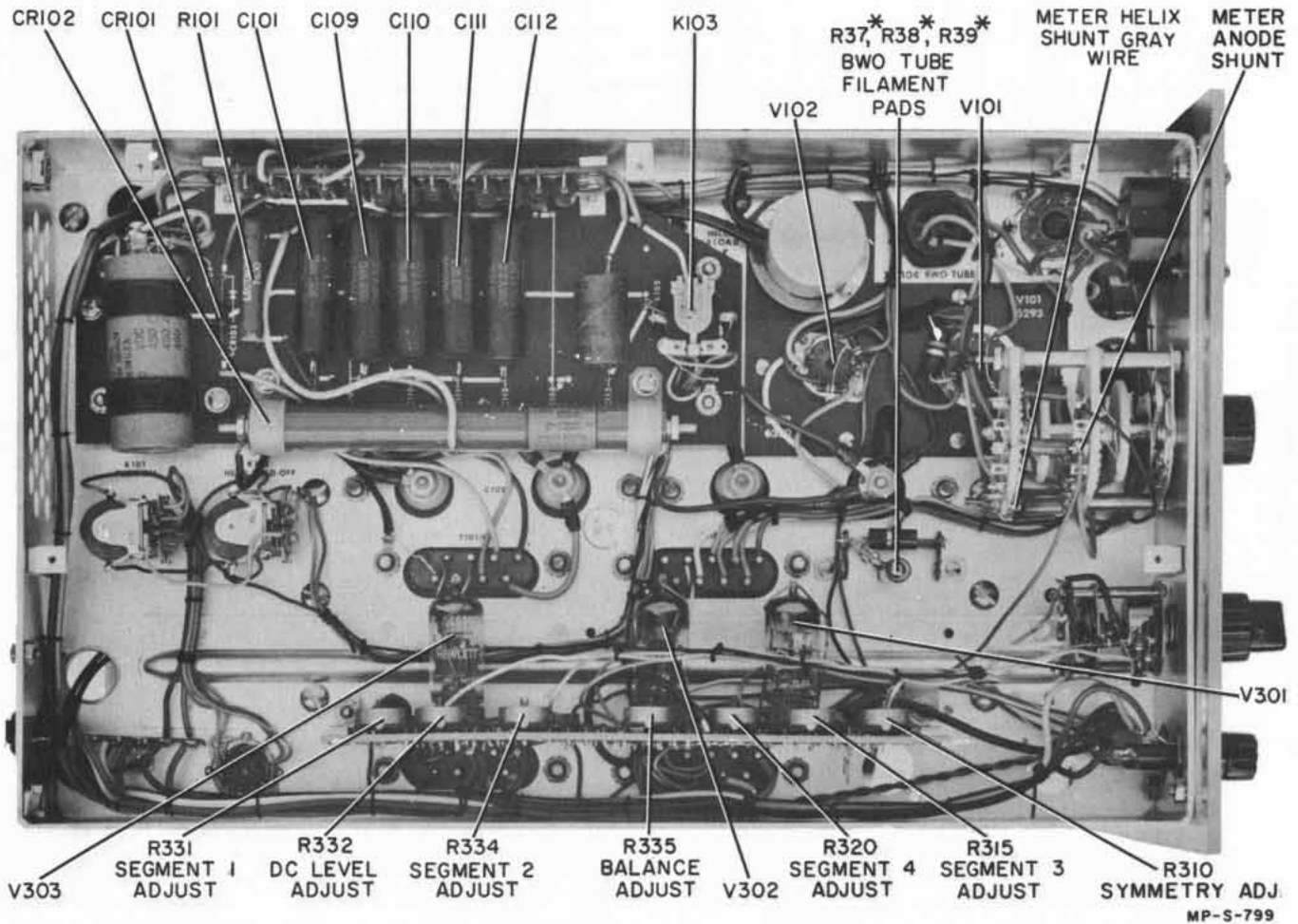

Figure 4-16. Model 686C Left Side View

B. SWEEP-OUT SAWTOOTH

The sawtooth voltage at the SWEEP OUTPUT jack (J203) is linear (see figures 4-6 and 4-17) and generally will not be out of specifications. Should trouble be experienced, however, the points discussed below are among the possible sources.

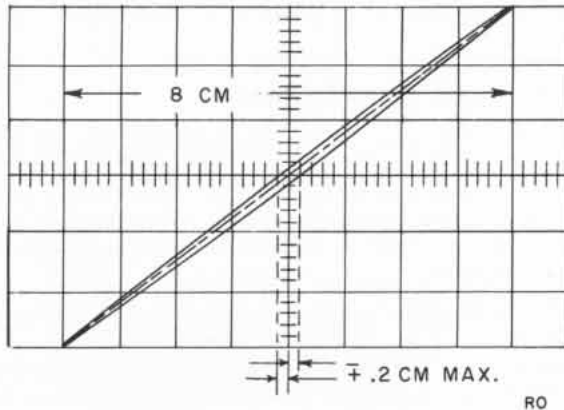

Figure 4-17. Sweep Out Voltage Linearity

Three troubles which may occur would cause a very distorted wave shape and thus can be easily detected. If W203 (6AL5) or V204 (6AN8) is defective, the sawtooth will be distorted. The defective tube generally has high heater-cathode leakage which modulates the sawtooth SWEEP OUTPUT voltage. Observing the sawtooth SWEEP OUTPUT voltage on an oscilloscope, distortion can easily be detected. Diode CR202, associated with the FREQUENCY potentiometer circuit, will cause limiting on the sawtooth if the diode has a low front-to-back ratio. If diode CR201 is defective, the cathode of V202B will not follow the grid. The grid will then draw current which will disable the swept circuit.

NOTE

When in good condition, G11A diodes will typically have a forward resistance of less than 100 ohms and a back resistance greater than 500,000 ohms. The actual resistance values read for diode CR201 or CR202 will vary with the internal voltage of the ohmmeter used. The above typical values are those read on an hp Model 410B vtm. The forward resistance is measured on the Rx1 range and the back resistance on the Rx1K or higher range.

If the sweep output voltage at J203 is too low or high, under approximately 20 volts or over approximately 25 volts, the Schmitt Trigger is probably not triggering reliably. This will also cause a non-linear sweep. In this case, V201 and/or V202A may be defective.

C. SETTING THE SCHMITT TRIGGER BIAS

The trigger bias should be adjusted with R203 (see figure 4-15). The equipment should be connected as in figure 4-2. Set the Δ FREQUENCY = 4.4K and SWEEP RATE to 3.2 kmc/sec. Adjust one wavemeter

pip at the low end of the hand and another at the high end. The end of the sweep should occur at the top of the wavemeter pip. Switch to TRIG. and operate the MAN. TRIG. button. Adjust R203 to obtain the same sweep length on MAN. TRIG as on RECUR. This is easy to determine if the sweep ends on the wavemeter pips.

4-18. REPLACING NEON DC COUPLING ELEMENTS.

Throughout the sweep oscillator there are a number of dc coupled circuits which use small neon lamps as coupling devices. These lamps maintain a constant voltage drop across themselves and thus couple together points of different potential. Since all power supplies are regulated and absolute voltage levels are critical, these lamps are important in maintaining exact voltage relationships in the system. The lamps are aged, polarized and selected at the factory. Lamps are aged on dc to insure stability of voltage level and to establish a polarity characteristic. The lamps are selected for proper voltage drop and color coded. The color tells the voltage and also tells the correct polarity. The paint mark is located on the positive lead. This is important, as improper polarity will result in a different and unstable voltage drop.

When replacing a lamp, the same color code lamp should be installed and care should be taken to observe the correct polarity. Improper connection may destroy the lamps' stability even if later reconnected in the proper manner.

The factory specifications on the lamps used in this sweep oscillator are as follows:

Stock No.	Color	Voltage Range	Circuit Reference
G84B	Blue	57 to 60V	V6 through V11, V209, V210
G84E	Red	61 to 65V	V110, V211

4-19. POSITIONING FREQUENCY DIAL ON POTENTIOMETER SHAFT.

If R236 has to be replaced, it is necessary to reset the proper relative position between the dial hub mechanical stop and the mechanical stop on the potentiometer rotor. Proper positioning of the stops will cause the dial stop to hit just before the internal rotor stop. This prevents possible damage to the precision potentiometer if the shaft is forced.

Proceed as follows:

- 1) Turn the FREQUENCY dial counterclockwise to the mechanical stop.
- 2) Record this position with a pencil mark on the dial.
- 3) Remove the long set screw on the dial hub (do not touch the short set screw!) and turn the FREQUENCY dial counterclockwise until it is stopped by the mechanical stop of the potentiometer rotor. Be careful not to use force.

- 4) Note the position of the dial with a pencil mark.
- 5) The two mechanical stops are in their proper relative location if the two pencil marks are 3/16 inch apart, measured on the edge of the dial.
- 6) To change the relative position of the two marks, release the short set screw on the dial hub.
- 7) Hold the potentiometer shaft fixed in its counterclockwise position and turn the dial to the correct location with the vernier. Tighten the short set screw.
- 8) Insert the long set screw which provides the mechanical stop. The screw should hit before the internal stop in the potentiometer both at full counterclockwise and full clockwise rotation.

B. POSITIONING FREQUENCY DIAL ON DIAL HUB

The FREQUENCY dial must be properly positioned on the potentiometer shaft for correct frequency calibration. The dial is set at the factory and should never need resetting unless R246 is replaced.

To gain access to the FREQUENCY dial set screws, loosen the two Allen set screws on the large black knob and slide the knob off the shaft.

Position the potentiometer wiper at the center tap point by connecting a low range ohmmeter between the wiper terminal (yellow lead) and the center tap

(green lead). Rotate the shaft until the ohmmeter reads a minimum (less than 1 ohm). Slip the FREQUENCY dial until the 10.0 kmc point is under the cursor. Carefully tighten the set screws. Recheck the position by rocking the dial each side of the 10.0 kmc point. The minimum resistance reading must exactly agree with the 10.0 kmc mark. Reposition the dial on the shaft if necessary. Remove the ohmmeter and re-install the knob on the dial shaft.

4-20. TUBE REPLACEMENT.

In many cases instrument malfunction can be corrected by replacing a weak or defective tube. Before changing the setting of any internal adjustment, check the tubes. Adjustments made in an attempt to compensate for a defective tube will often complicate the repair problem.

It is a good practice to check tubes by substitution rather than by using a "tube checker." The results obtained from the "tube checker" can be misleading. Before removing a tube, mark it so that if the tube is good it can be returned to the same socket. Replace only tubes proved to be weak or defective.

Any tube with corresponding standard EIA (JEDEC) characteristics can be used as a replacement. Where variation in tube characteristics will affect circuit performance, an adjustment is provided. Table 4-1 lists the tests and adjustments which should be performed if such tubes are replaced.

Table 4-1. Tube Replacement Chart

Tube	Function	Standard Test or Adjustment
V201	Schmitt Trigger, Linear Sweep Time Generator, figure 4-24.	Adjust sweep time; see paragraph 4-12. Adjust schmitt trigger bias; see paragraph 4-17C.
V204	Feedback Integrator, Linear Sweep Time Generator, figure 4-24.	Adjust sweep time; see paragraph 4-12.
V207A	Control Tube, Helix Supply Reference Voltage Generator, figure 4-24.	Check FREQUENCY dial setting; see paragraph 4-13C.
V207B	Series Regulator, Helix Supply Reference Voltage Generator, figure 4-24.	Check calibration adjustment pots (R245-251) paragraph 4-14, steps 1 through 12.
V208	Differential Amplifier, Helix Supply Reference Voltage Generator, figure 4-24.	Check calibration adjustment pots (R245-251) paragraph 4-14, steps 1 through 12.
V301	Amplifier/Square-Wave Generator, figure 4-22.	Adjust square-wave symmetry; see paragraph 4-15.
V302 V303	RF Leveler and Reference Anode Voltage Supply, figure 4-22.	Adjust R332, see paragraph 4-16.

Table 4-2. Troubleshooting Procedure (Sheet 1 of 4)

The purpose of the troubleshooting chart is 1) to provide a logical sequence for troubleshooting the 686C, 2) to isolate trouble to a circuit rather than to a component, and 3) to point out some of the more common troubles which might occur in the stage.

The troubleshooting chart (figure 4-18) is sectionalized by symptoms, as follows: 1) NO RF POWER OUTPUT, 2) NO SWEEP OUTPUT, 3) RF SWEEP JITTER AND/OR FREQUENCY SHIFT, 4) LOW RF POWER OUTPUT AND/OR EXCESSIVE POWER SPREAD, and 5) NO AMPLITUDE MODULATION.

Each section is divided into circuit blocks and trouble blocks. Only those circuits to be checked and related troubles are included in each section. Arrowed solid lines indicate circuit relationships and signal direction between circuits. Dotted lines connect circuit blocks to trouble blocks. Where dotted lines extend from a circuit block in one section to a trouble block in another section, such troubles will be indicated by the symptoms which head the section in which the trouble block appears. To isolate the trouble causing the symptom, proceed in the order shown in that section.

As an aid in localizing the trouble within a section, a simplified trouble location procedure is included which gives step-by-step procedures for trouble isolation within a section.

SECTION I

VERY LOW OR NO RF OUTPUT POWER

Step 1. Low Voltage Power Supply

A. -150 Volt Regulated Power Supply

- 1) Check -150 volts. No -150 volts, proceed as instructed below.
 - a. Remove primary power from 686C and measure resistance from -150 volt terminal (any white wire) to ground; should be approximately 33K ohms.
 - b. Check high voltage fuse (front panel).
 - c. Check voltage output across C121; should be approximately 420 volts. Possible trouble, CR105 and CR106. If not, continue to 4.
 - d. Replace V107, V109, and V108 in that order.
 - e. Refer to paragraph 4-8 and calibrate the -150 volt power supply.

B. +300 Volt Regulated Power Supply.

Check +300 volts; no +300 volts, proceed as instructed below.

- a. Remove primary power from 686C and measure resistance from +300 volt terminal to chassis ground; should be approximately 30K ohms.
- b. Measure voltage across C119; should be approximately 450 volts. Possible trouble CR103 and CR104.
- c. Replace V106, and V107 in that order.
- d. Refer to paragraph 4-9 and calibrate the 300 volt power supply.

Step 2. Regulated Magnet Supply

A. Magnet Current Check

- 1) Rotate CURRENT selector to MAGNET.
- 2) After the 686C has been in operation for 5 minutes, read front panel meter; should read approximately 0.7 ampere. If magnet current is very low (zero to 0.5 ampere) proceed as instructed below.

B. Magnet Trouble Procedure

- 1) Check magnet fuse (front panel). Check only if there is no magnet current.
- 2) Check voltage from pin 1, 5 of V3 (ground lead of dc vtm) and pin 2, 5 of V1 (positive lead of dc vtm); should be approximately +220 volts. Possible trouble CR1 or CR2.
- 3) Check voltage from pin 1, 5 of V3 (ground lead of dc vtm) to pin 2, 4, 7 of V3 (positive lead of dc vtm); should read approximately -150 volts. Possible trouble, CR3, or V3. Proceed to 4.
- 4) Replace V4 and V5.
- 5) Check neon lamps V6 through V11.
- 6) Refer to para. 4-7 to calibrate magnet circuit.

Step 3. Filament Circuit (R35)

- 1) Check filament voltage for V103, V105, V107, V109, V202, V207, V208 and V302. Place an ac vtm across R32 (see right side view, figure 4-15). No 6.3 volts ac, replace R35.

- 2) Refer to paragraph 4-11 and calibrate filament circuit.

Step 4. Filament Circuit (R36)

Check filament voltage for V104 by placing an ac vtm across parallel combination of R37, R38, R39 (see figure 4-16, left side view); no 6.3 volts ac, replace R36.

Step 5. High Voltage Supply

Check high voltage between red lead, C102, and chassis ground. Voltage should be approximately 2500 volts. No voltage or very low voltage, check CR101.

Step 6. Collector Supply

Replace V102.

Step 7. BWO Tube.

Refer to paragraph 4-13 Replacement of Backward-Wave Oscillator Tube and Calibration Procedure.

Table 4-2. Troubleshooting Procedure (Sheet 2 of 4)

SECTION II
NO RF SWEEP OUTPUT

Step 1. Linear Sweep Generator

- A. Check for 20-25 volt sawtooth at SWEEP OUTPUT jack (front panel).
- B. No Sweep.
- 1) Rotate SWEEP SELECTOR to RECUR.
 - 2) Rotate A FREQUENCY to 4.4 kmc.
 - 3) Rotate RF SWEEP MC/SEC to 320K.
 - 4) Connect a jumper between pin 2, V201 and -150 volts (reg.). This will disable the Schmitt Trigger.
 - 5) Check voltage at plate pin 7, V203; should be approximately -1.8 volts. Possible trouble: V204, V211.
 - 6) Check voltage at cathode, pin 1, V203; should be approximately +0.06 volt. If not, replace V203.
 - 7) Check voltage at grid, pin 8 of V204; should be approximately -1.8 volts. Possible trouble: V204, V211.
 - 8) Check voltage at cathode pin 1 of V204; should be approximately -1.2 volts. Possible trouble: V204, V211.
 - 9) Check voltage at plate pin 6, V204; should be approximately 63 volts. If not, replace V211 neon lamp.
 - 10) Check voltage at grid pin 2, V202; should be approximately -120 volts. If not, check voltage divider stick consisting of R212 and R213.
 - 11) Check voltage at cathode pin 8 of V202; should be approximately -0.35 volt. If not, adjust R217 and/or replace R201.
 - 12) Remove jumper between pin 2, V201 and -150 volts.
 - 13) Refer to paragraph 4-12 and 4-14 to calibrate sweep circuit.

Step 2. Helix Supply Reference Voltage Generator

- 1) Check +150 volts between pin 1,5 of V206 and ground. Possible trouble: V206.
- 2) Rotate SWEEP SELECTOR to ON.
- 3) Check exponential waveform with oscilloscope at pin 2, V105. No exponential sweep, proceed as instructed below.
- 4) Rotate SWEEP SELECTOR to OFF.
- 5) Connect a dc vtvm (+150 volt range) between pin 8, V207 and ground. Rotate FREQUENCY dial; voltage should vary with FREQUENCY dial variation. Possible trouble: R236.
- 6) Place dc vtvm (+300 volts range) between pin 6, V207 and ground. Rotate FREQUENCY dial; voltage at pin 6 of V207 should follow FREQUENCY dial variation. Possible trouble: V207, V205, CR204.
- 7) Refer to paragraph 4-14 and calibrate sweep length.

Step 3. Regulated Helix Supply

- 1) SWEEP SELECTOR to OFF.
- 2) Connect a dc vtvm, with a range of 200 to 2500 volts, from pin 8 of V101 to ground and rotate FREQUENCY dial from 8.2 to 12.4 kmc. Voltage variation should be approximately 350 to 220 volts. Possible trouble: V103, V105, V110, C114.

DANGER

High voltage; remove primary power before making connections.

- 3) Refer to paragraph 4-13C and calibrate FREQUENCY dial.

Table 4-2. Troubleshooting Procedure (Sheet 3 of 4)

SECTION III
RF JITTER AND/OR FREQUENCY SHIFT

Step 1. Low Voltage Power Supply

A. -150 volt Power Supply.

- 1) RF Jitter.
 - a. Connect an ac vtvm between ground and -150 volt terminal (any white wire) in power supply.
 - b. If ripple voltage exceeds 3 millivolts, possible trouble: V108, V109.

2) Frequency Shift

- a. Place a dc vtvm between ground and -150 volt terminal (any white wire) and vary power line voltage from 103 to 127 volts. If -150 volts varies, replace V107 and V109.
- b. Refer to paragraph 4-8 and calibrate -150 volt supply.

B. +300 Volt Supply.

- 1) RF Jitter.
 - a. Connect an ac vtvm between ground and +300 volt lead (any solid red lead) +300 volt regulated supply. If ripple voltage exceeds 10 millivolts, replace V107 and V109.
 - b. Refer to paragraph 4-9 and calibrate +300 volt supply.

Step 2. Regulated Magnet Supply

A. RF Jitter.

- 1) Connect a floating ac vtvm with its ground lead at pin 1.5 and its positive lead to one side of R40.
- 2) Vary power line voltage from 103 to 127 volts ac and observe ripple voltage on ac vtvm.
- 3) If ripple voltage exceeds 100 millivolts, possible trouble: V5, V6 through V11.
- 4) Refer to paragraph 4-7 and calibrate magnet power supply.

NOTE

In the case of the neon lamps V6 through V11, the faulty neon lamp can be isolated by shunting a 470K resistor across each neon while watching the ripple indication of the ac vtvm. When ripple indication on ac vtvm dips the faulty neon lamp has been isolated and should be replaced.

B. Frequency Shift.

- 1) Rotate CURRENT selector to MAGNET.

- 2) Vary power line voltage from 103 to 127 volts ac. Magnet current should not vary more than ± 0.25 ampere. Allow time for the magnet supply to settle before the power line voltage is changed and the current reading is taken.

- 3) Possible trouble: control tube V5 or neon lamps V6 through V11.

- 4) Refer to paragraph 4-7 and calibrate magnet supply.

Step 3. Linear Sweep Generator

A. RF Jitter.

- 1) Connect oscilloscope to SWEEP OUTPUT jack; SWEEP SELECTOR to RECUR.
- 2) Check sawtooth displayed on oscilloscope for jitter. If jitter is present, possible trouble: V203, V211, V209, V210.

B. RF Frequency Shift.

The linear sweep generator should not cause frequency shift and can be eliminated as a possible source of trouble. Proceed to next step.

Step 4. Exponential Sweep Generator.

A. RF Jitter.

- 1) 686C Front Panel settings:
 SWEEP SELECTOR RECUR
 Δ FREQUENCY 4.4 kmc
 SWEEP RATE 320K
 AMPL. MOD. SELECTOR OFF
 FREQUENCY dial 12.4 kmc

- 2) Connect oscilloscope probe from pin 5, V205 and observe exponential waveform. If there is jitter of the exponential sweep, possible trouble: CR204, V206, V207, V208, V209.

B. Frequency Shift.

The exponential sweep generator should not cause momentary frequency shifts; thus the circuit can be eliminated as a possible frequency shift trouble. Proceed to next step.

Step 5. Regulated Helix Supply.

A. RF Jitter.

- 1) Front panel control settings same as in step 6A1.
- 2) Place oscilloscope probe at pin 1, V105 and observe exponential waveform on oscilloscope. If there is jitter of the exponential sweep, possible trouble: V105, V103, V110, L101.

Table 4-2. Troubleshooting Procedure (Sheet 4 of 4)

SECTION IV
RF LEVELER AND REFERENCE ANODE CIRCUIT

Step 1. Reference Anode Circuit

A. Low Power

1) Adjust DC Level Adj. R332 to obtain minimum of 10 milliwatts at low power point. See paragraph 4-15 and calibrate rf leveler circuit.

2) Replace two tube; refer to paragraph 4-13.

B. Excessive Power Spread.

Connect an oscilloscope to the output of cathode follower V303B and observe waveform. Vary Segment 1, 2, 3, 4 adjusts; should also vary presentation on the oscilloscope. If not, possible trouble: CR302, CR303, CR304.

A. Set the SWEEP SELECTOR to OFF.

B. Rotate MOD. SELECTOR to all three modulating positions, INT., PULSE and EXT., applying an external signal where appropriate. If there is no modulation output for all positions of the AMPL. MOD. SELECTOR, possible trouble: CR301, V301. Refer to paragraph 4-15 and calibrate circuit.

C. Rotate AMPL. MOD. SELECTOR to INT.; NO square wave output. Possible trouble: V301, C302, S301.

D. No PULSE modulation, all other modulation positions operating normally. Possible trouble: S301

SECTION V
AMPL. MOD. CIRCUIT

A. Set the SWEEP SELECTOR to OFF.

B. Rotate MOD. SELECTOR to all three modulating positions, INT., PULSE and EXT., applying an external signal where appropriate. If there is no modulation output for all positions of the AMP. MOD. SELECTOR, possible trouble: CR301, V301. Refer to paragraph 4-15 and calibrate circuit.

C. Rotate AMPL. MOD. SELECTOR to INT.; NO square wave output. Possible trouble: V301, C302 S301.

D. No PULSE modulation, all other modulation positions operating normally. Possible trouble: S301.

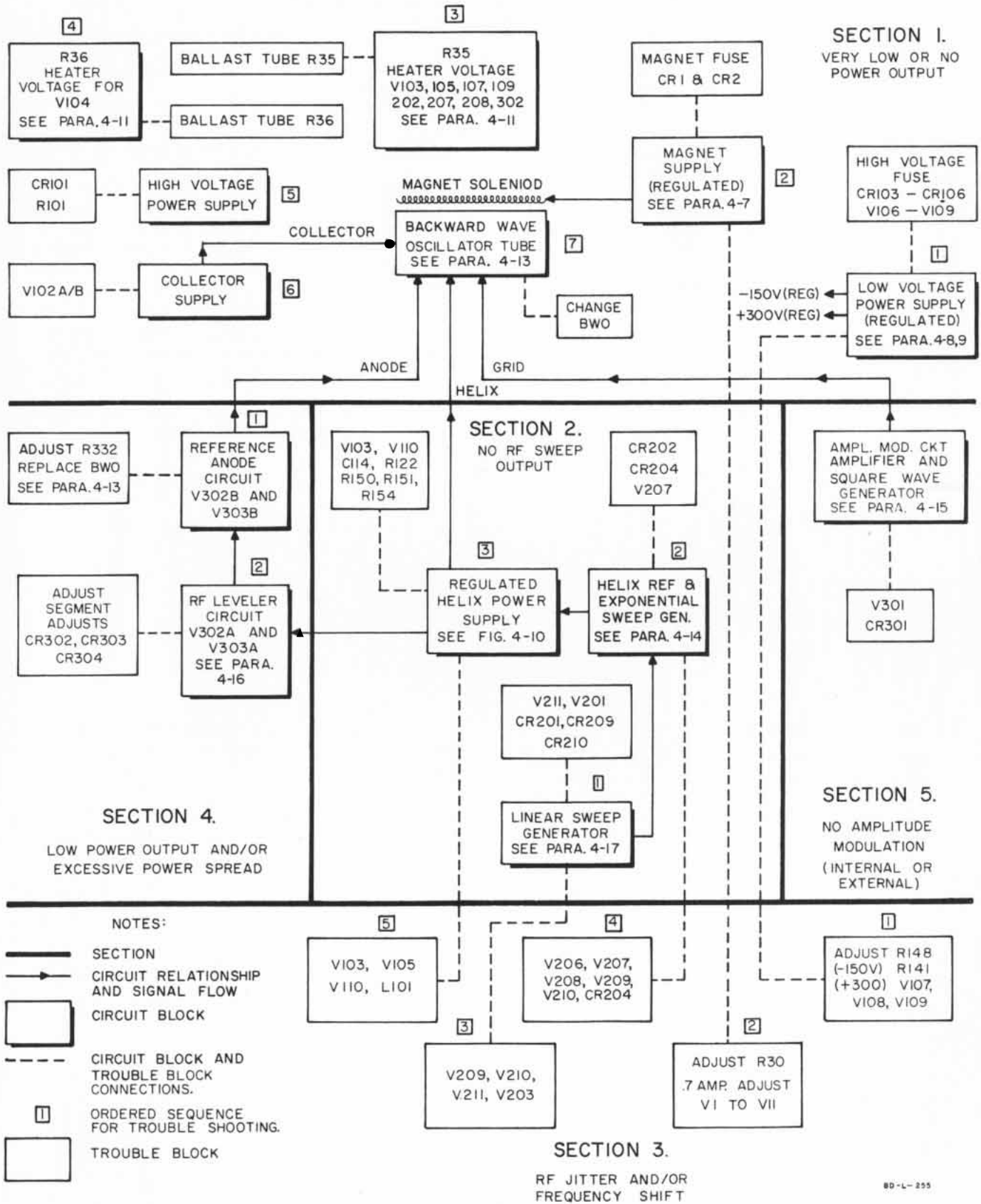

Figure 4-18. Troubleshooting Chart

SCHEMATIC DIAGRAM NOTES

1. Heavy box indicates front-panel engraving.
2. Resistance values in ohms, inductance in microhenries, and capacitance in picofarads unless otherwise specified.
3. Relays shown in de-energized position.
4. (*) Indicates a padded resistor, electrical value adjusted at factory. Average value shown.

VOLTAGE AND RESISTANCE DIAGRAM NOTES

1. Voltage values shown with an (*) are for guidance. Values may vary from those shown, due to tube aging or normal differences between instruments. Resistance values may vary considerably from those shown when the circuit contains potentiometers, crystal diodes, or electrolytic capacitors.
2. A solid line between socket terminals indicates a connection external to the tube between the terminals; a dotted line between terminals indicates a connection inside the tube. Voltage and resistance are given at only one of the two joined terminals.
3. Unless otherwise specified, dc and resistance measurements made with an $\text{\textcircled{P}}$ Model 410B VT-VOM (122 megohms input impedance), common lead connected to chassis. DC voltages over 1000 volts measured with an $\text{\textcircled{P}}$ Model 459A, 100:1 multiplier probe of 12,000 megohms input resistance.
4. AC voltage, except ripple measurements, made with multimeter of 5000 ohms-per-volt sensitivity $\pm 2\%$ accuracy. Ripple measurements made with $\text{\textcircled{P}}$ Model 400D AC-VTVM (0.001V fs max sensitivity, 10 megohms input impedance).
5. Instrument operating under cw conditions at 10.3 kmc. CATHODE current at value marked on meter panel.
6. Resistance measurements made with all controls full counterclockwise and FREQUENCY dial at 10.3 kmc.

MAGNET POWER SUPPLY (CURRENT REGULATED) VOLTAGE-RESISTANCE DIAGRAM

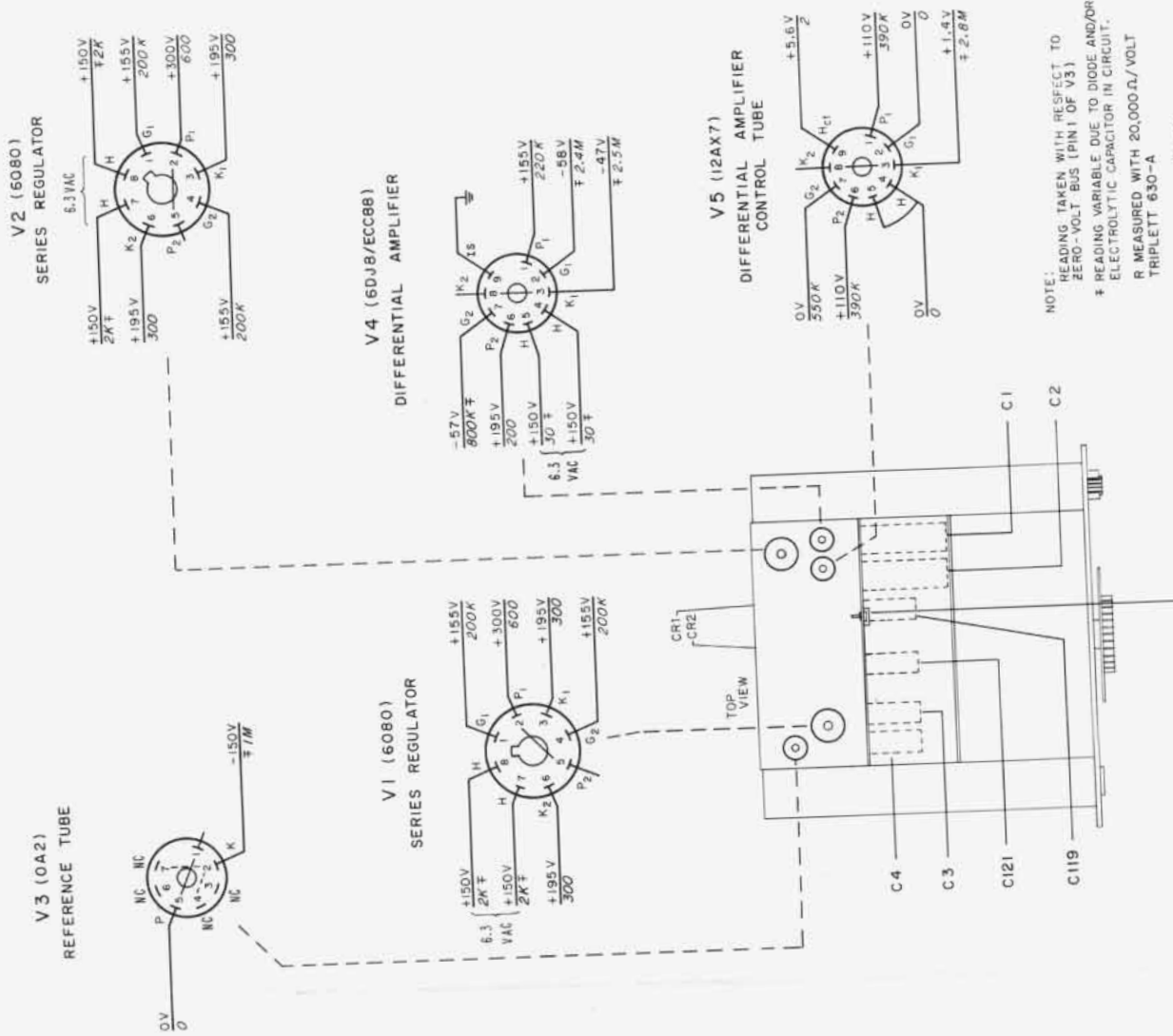

POWER SUPPLY TURN-ON SEQUENCE OF OPERATIONS

1. Closing front panel switch S101 applies 115 volts ac through F101 to magnet supply rectifier/doubler (CR1, CR2, C1, C2). The return path from C1 and C2 is through T101 6.3-volt secondary winding (A6) - (A5) to T1 terminal (A2) to other side of power line.
2. In addition, closing S101 applies power to T1, fan B101, and to the heater of thermal time delay switch S102. The circuit to S102 heater is from T1 (A3) through back contacts of K101, K102, through heater and back to T1 (A4).
3. Thermal time delay switch S102 operates after 60 seconds, connecting K101 coil across a 6.3-volt secondary winding of transformer T1. The K101 operating circuit is from T1 winding A7, through K101 coil, S102 contacts, K102 back contacts to T1 (A8).
4. Delayed Turn-on Relay K101 operates and 1) breaks circuit to S102 heater, 2) completes circuit to T101 primary, and 3) closes holding contacts in parallel with S102 contacts to keep K101 energized after S102 cools off.

Instrument is now fully energized.

OVERLOAD PROTECTION OPERATION

1. Excessive current (approximately 3.0 ma) through coil of helix overload relay K103 causes it to operate and in turn close circuit to K102 coil.
 2. K102 operates and 1) at its break contacts opens holding circuit to K101 which de-energizes and disconnects power from T101 primary, and at its make contacts closes contacts in parallel with K103 contacts to hold K102 energized, and 2) opens operating circuit to S102 heater.
- High voltage circuits energized from T101 are now disabled until K102 restores. To reset the overload circuits, momentarily turn off main power switch S101. With power off, T1 and K102 de-energize, and K102 closes its back contacts to prepare the operating circuit to time delay switch S102 and delayed turn-on relay K101. Power supply delayed turn-on circuits will recycle as soon as S101 is again turned on.

Figure 4-19. Magnet Power Supply (Current Regulated)

BWO MAGNET CURRENT REGULATOR

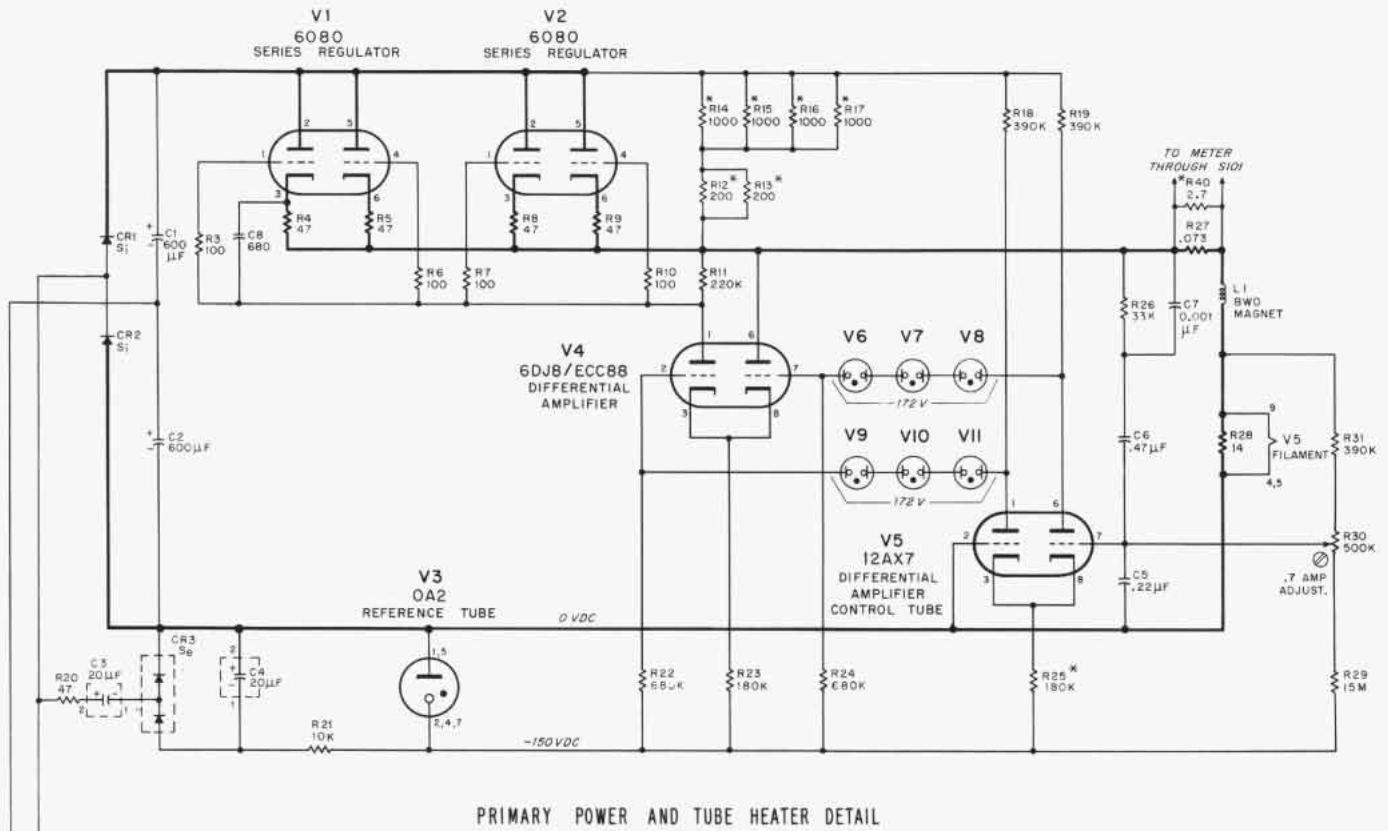

PRIMARY POWER AND TUBE HEATER DETAIL

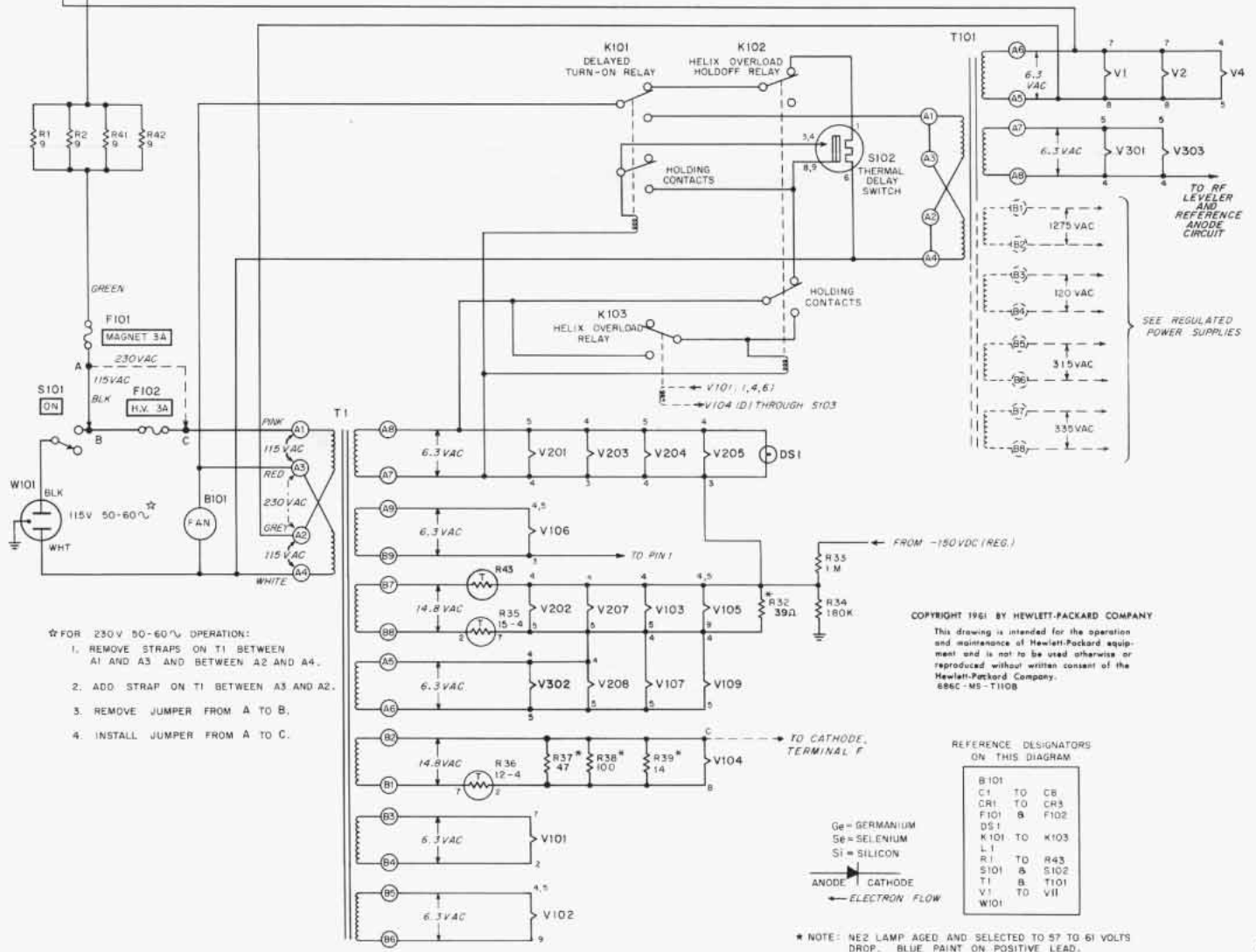

★ FOR 230V 50-60 \angle OPERATION:

1. REMOVE STRAPS ON T1 BETWEEN A1 AND A3 AND BETWEEN A2 AND A4.
2. ADD STRAP ON T1 BETWEEN A3 AND A2.
3. REMOVE JUMPER FROM A TO B.
4. INSTALL JUMPER FROM A TO C.

REFERENCE DESIGNATORS ON THIS DIAGRAM

B101	TO	C8
C1	TO	C8
CR1	TO	CR3
F101	8	F102
DS1	8	T101
K101	TO	K103
L1	TO	K103
R1	TO	R43
S101	8	S102
T1	8	T101
V1	TO	V11
W101	TO	V11



★ NOTE: NE2 LAMP AGED AND SELECTED TO 57 TO 61 VOLTS DROP. BLUE PAINT ON POSITIVE LEAD.

Figure 4-20. Primary Power and Regulated Magnet Supply

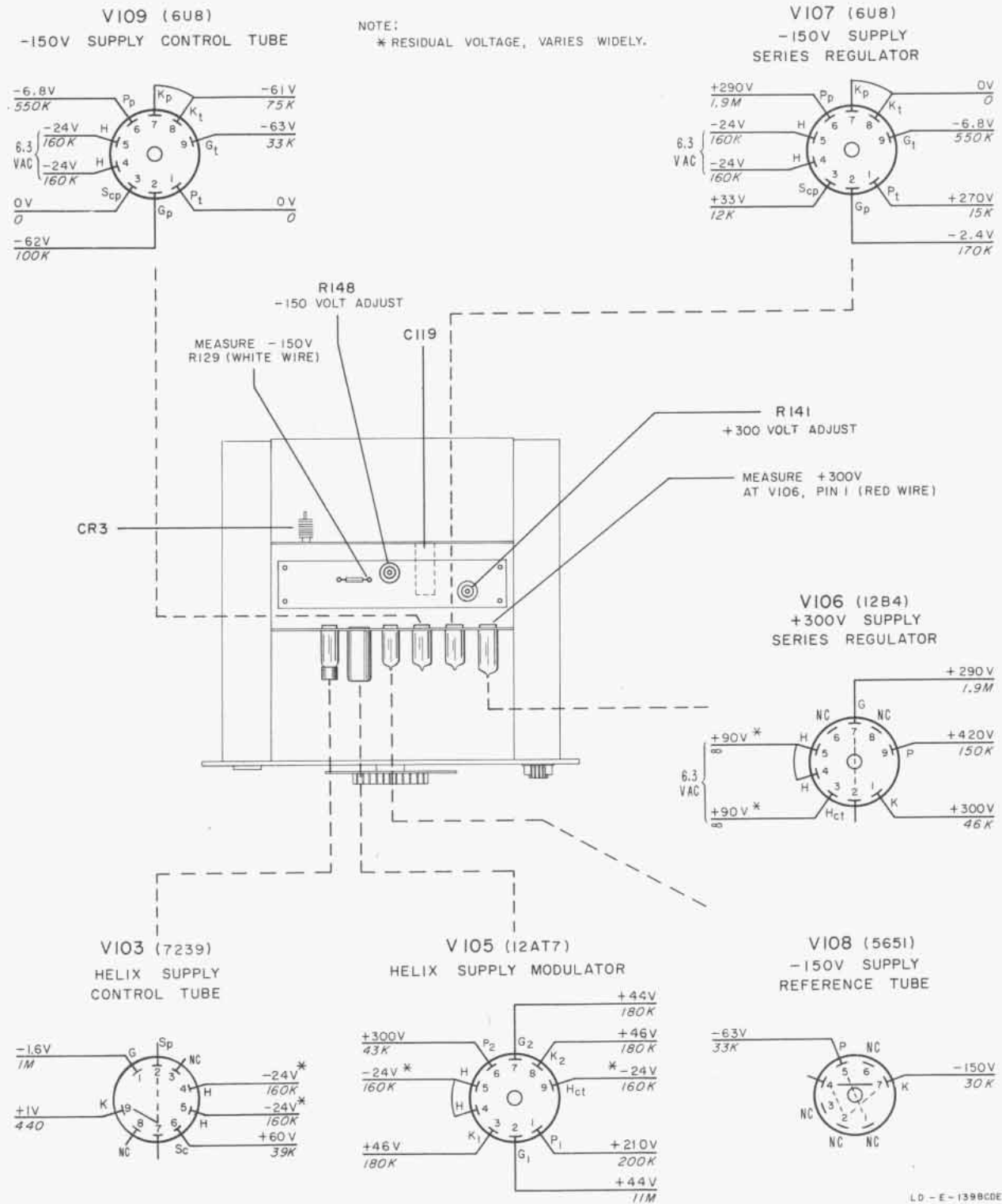

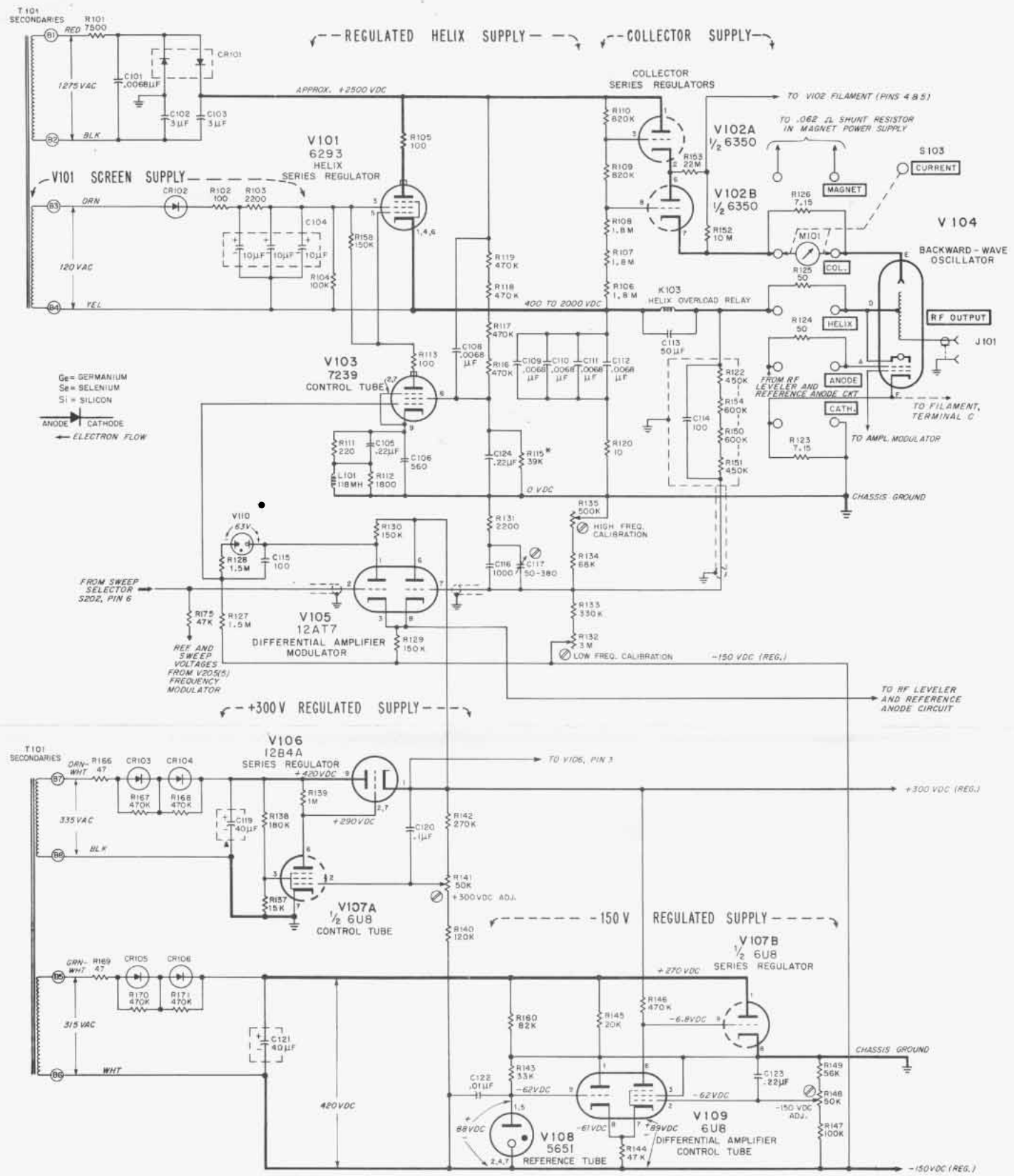

Ge = GERMANIUM
 Se = SELENIUM
 Si = SILICON

ANODE → CATHODE
 ← ELECTRON FLOW

REFERENCE DESIGNATORS

- C101 - C124
- CR101 - CR106
- J101
- L101
- R101 - R57, R66 - R71, R75 - R135
- V101 - V110
- M101

UNASSIGNED:
 R114, R121, R136, R155 - R157
 R159 - R65, R72 - R74
 C107, R18

NOTES:
 SEE PRIMARY POWER & MAGNET CURRENT SUPPLY DWG. FOR B101, F101, F102, K101, K102, K103, S101, S102, W101 AND PART OF T101.
 *NE2 LAMP AGED AND SELECTED FOR 61 TO 65V DROP; RED PAINT ON POSITIVE LEAD.

COPYRIGHT 1961 BY HEWLETT-PACKARD COMPANY
 This drawing is intended for the operation and maintenance of Hewlett-Packard equipment and is not to be used otherwise without the written consent of the Hewlett-Packard Company.
 686C - REG P 5 T103

Figure 4-22. Low Voltages and Regulated Helix Supply

VOLTAGE-RESISTANCE DIAGRAM

CONDITIONS FOR MEASUREMENT:

1. SWEEP SELECTOR OFF
2. FREQUENCY DIAL AT 12.4KMC
3. RF POWER LEVELER ON
4. AMPLITUDE MOD OFF

V102 (6350)
BWO COLLECTOR SERIES
REGULATORS

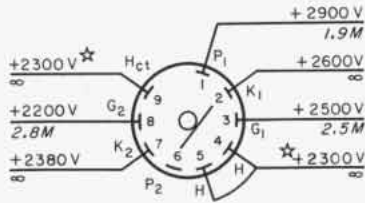

V104 (212-130)
BACKWARD WAVE OSCILLATOR

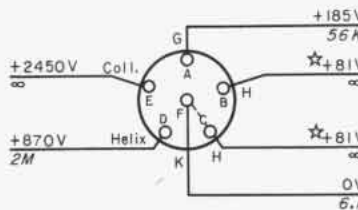

V101 (6293)
HELIX SERIES REGULATOR

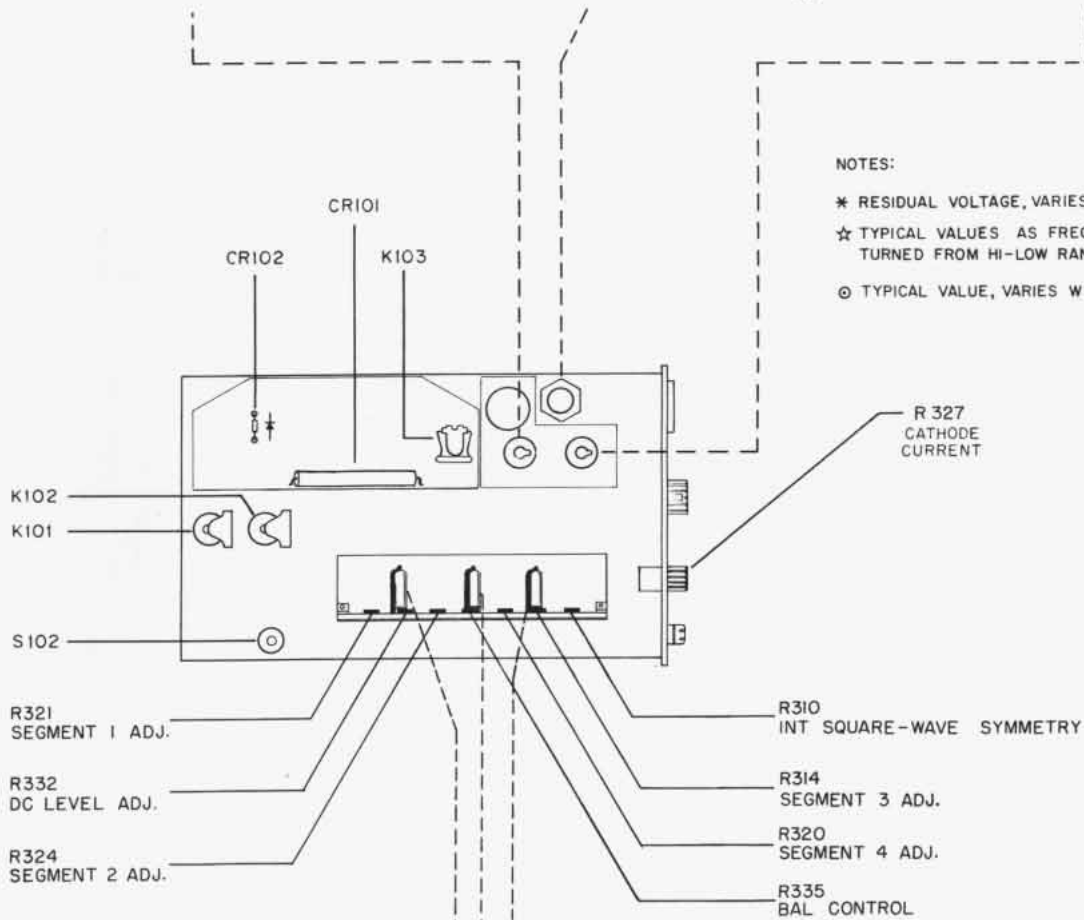
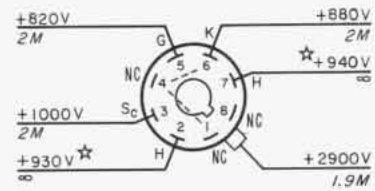

NOTES:

- * RESIDUAL VOLTAGE, VARIES WIDELY.
- ☆ TYPICAL VALUES AS FREQUENCY DIAL IS TURNED FROM HI-LOW RANGE.
- ⊙ TYPICAL VALUE, VARIES WIDELY.

V303 (6DJ8/ECC88)
CATHODE FOLLOWER

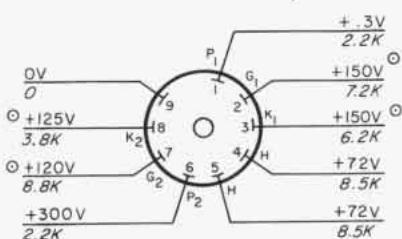

V302 (6DJ8/ECC88)
REFERENCE AMPLIFIER
& INVERTER

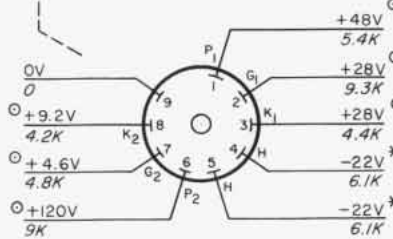

V301 (6DJ8/ECC88)
AMPLIFIER SQUARE-WAVE
GENERATOR

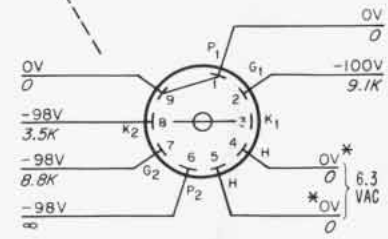

LO-L-445

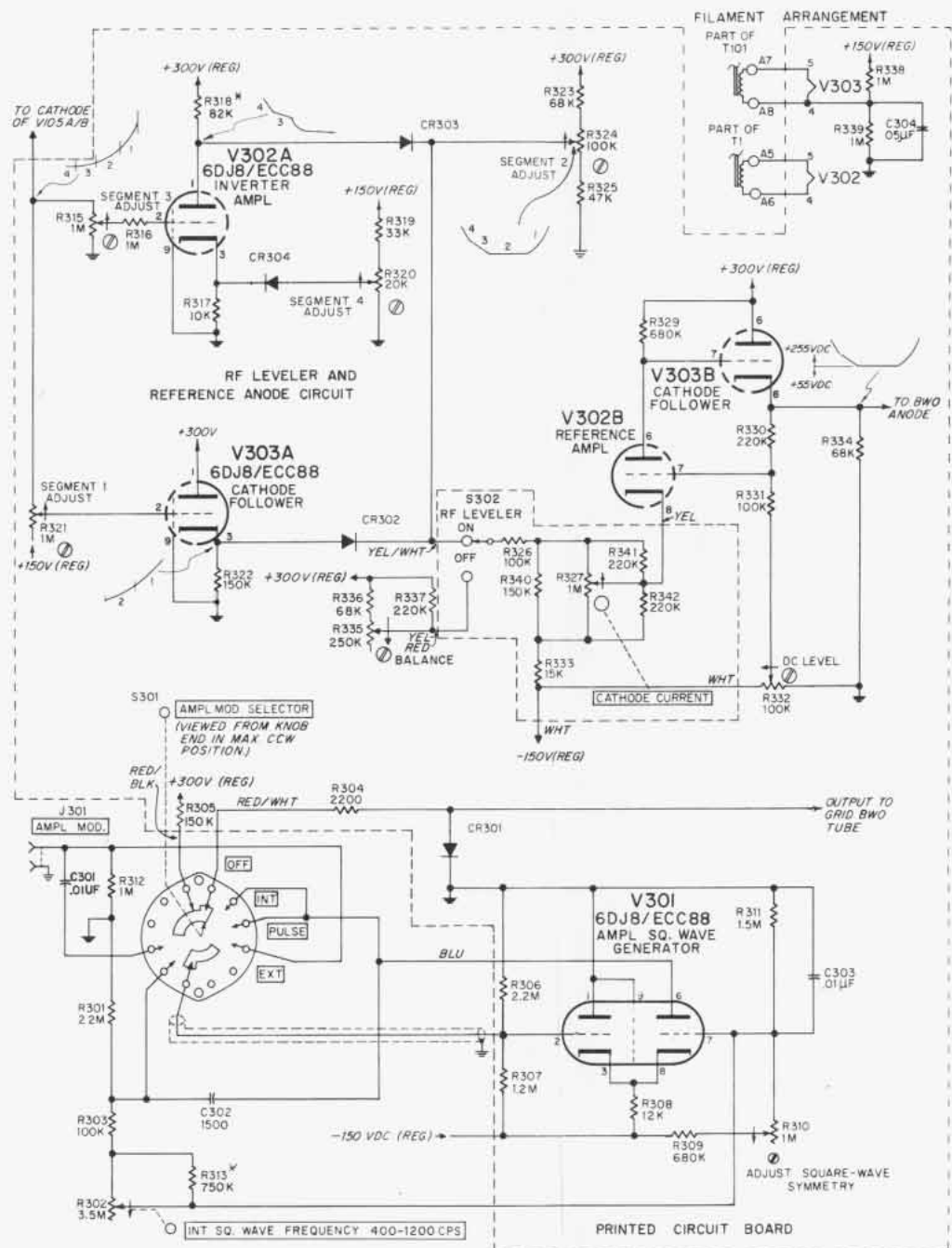

AMPL MODULATION AND ANODE SECTION

COPYRIGHT 1961 BY HEWLETT-PACKARD COMPANY
 This drawing is intended for the operation and maintenance of Hewlett-Packard equipment and is not to be used otherwise or reproduced without written consent of the Hewlett-Packard Company.
 680C-AMPL. MOD. AND. ANODE SEC. T10A

REFERENCE DESIGNATORS

C301 - C304
CR301 - CR304
J301
R301 - 313, 315 - 327, 329 - 342
S301, S302
V301 - V303

Figure 4-24. Amplitude Modulator and Reference Anode Circuit

FREQUENCY (BWO HELIX) MODULATOR VOLTAGE-RESISTANCE DIAGRAM

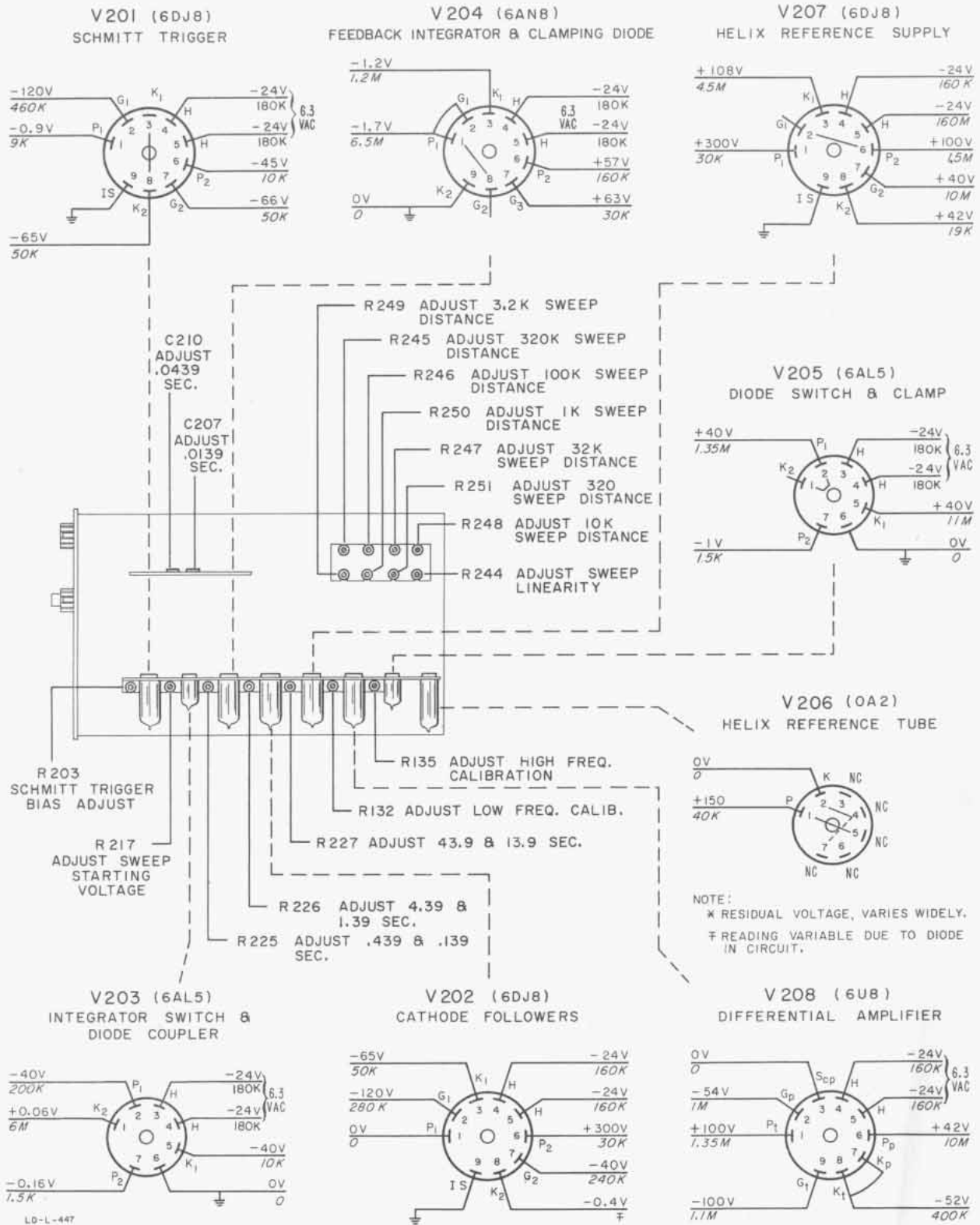

Figure 4-25. Frequency (BWO Helix) Modulator

EXPONENTIAL HELIX SWEEP GENERATOR

HELIX SUPPLY REFERENCE VOLTAGE GENERATOR

COPYRIGHT 1961 BY HEWLETT-PACKARD COMPANY
This drawing is intended for the operation and maintenance of Hewlett-Packard equipment and is not to be used otherwise or reproduced without written consent of the copyright owner.
686C - 7th EDITION - 1-60

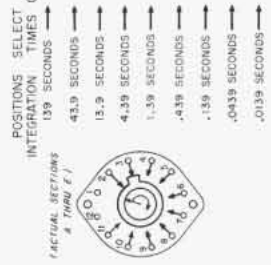
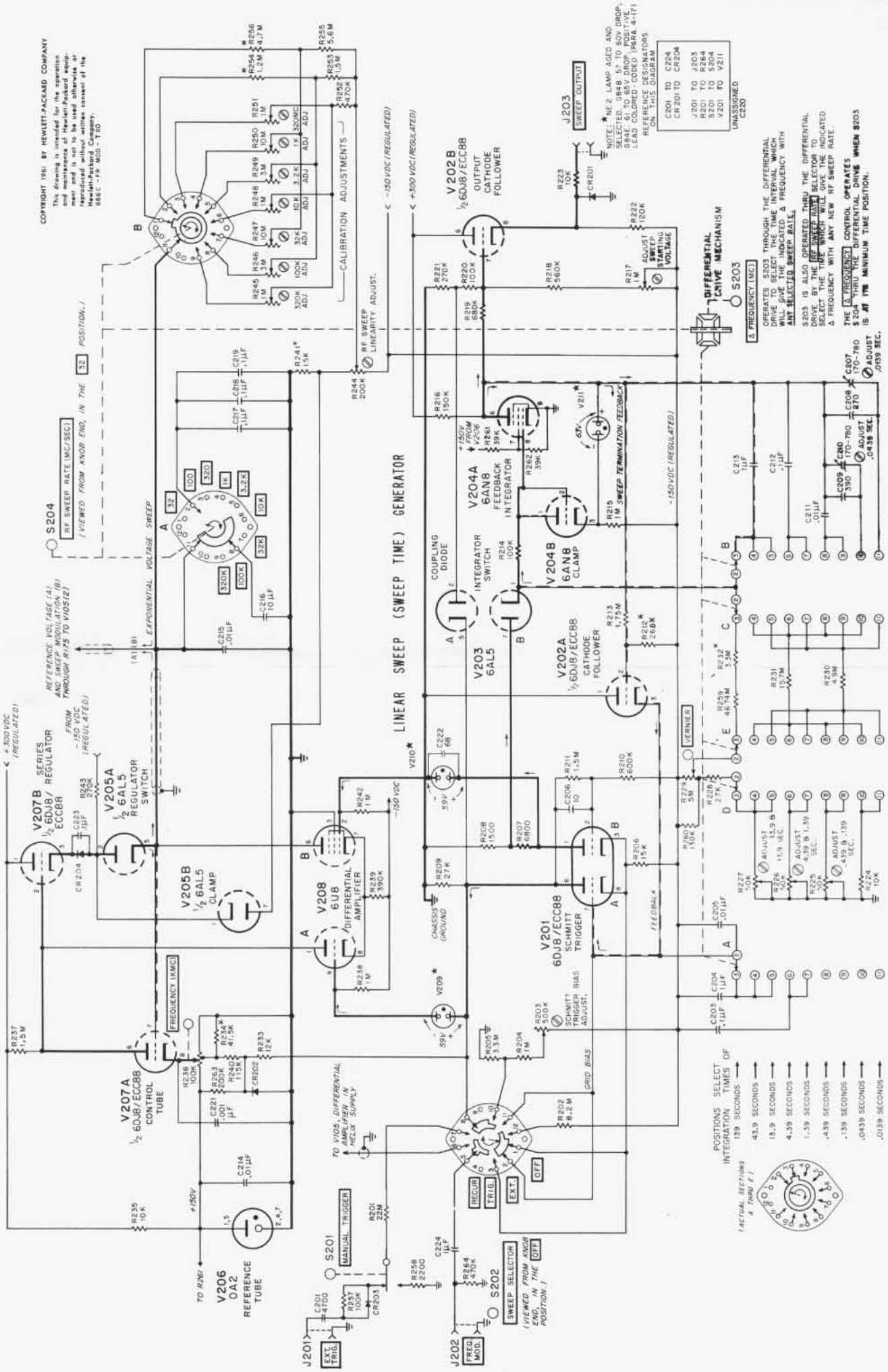

Figure 4-26. Linear and Exponential Sweep Generator Circuit

SECTION V REPLACEABLE PARTS

5-1. INTRODUCTION.

This section contains information for ordering replacement parts for the 686C sweep oscillator.

Table 5-1 lists replaceable parts in alpha-numerical order of their reference designators. Detailed information on a part used more than once in the instrument is listed opposite the first reference designator applying to the part. Other reference designators applying to the same part refer to the initial designator. Miscellaneous parts are included at the end of the list. Detailed information includes the following:

- 1) Reference designator.
- 2) Full description of the part.
- 3) Manufacturer of the part in a five-digit code; see list of manufacturers in appendix.
- 4) Hewlett-Packard stock number.
- 5) Total quantity used in the instrument (TQ col).
- 6) Recommended spare quantity for complete maintenance during one year of isolated service (RS col).

5-2. ORDERING INFORMATION

To order a replacement part, address order/or inquiry either to your authorized Hewlett-Packard sales office or to

CUSTOMER SERVICE
Hewlett-Packard Company
395 Page Mill Road
Palo Alto, California,

or, in Western Europe, to

Hewlett-Packard S. A.
Rue du Vieux Billard No. 1
Geneva, Switzerland.

Specify the following information for each part:

- 1) Model and complete serial number of instrument.
- 2) Hewlett-Packard stock number.
- 3) Circuit reference designator.
- 4) Description.

To order a part not listed in table 5-1, give a complete description of the part and include its function and location.

Table 5-1. Replaceable Parts (Sheet 1 of 17)

Ckt Ref.	Description	Mfr *	hp Stock No.	TQ*	RS*		
B1 thru B100	Not assigned						
B101	Fan motor	06812	3140-0011	1	1		
	Fan blade	06812	3160-0015	1	1		
C1, 2	Capacitor: fixed, electrolytic, 600 uf, 200 vdcw	56289	0180-0046	2	1		
C3, 4	Capacitor: fixed, electrolytic, 20 uf, 450 vdcw	56289	0180-0011	2	1		
C5	Capacitor: fixed, paper, 0.22 uf ±10%, 400 vdcw	56289	0160-0018	1	1		
C6	Capacitor: fixed, paper, 0.47 uf ±10%, 200 vdcw	56289	0160-0015	1	1		
C7	Capacitor: fixed, mica, 1000 pf ±10%, 500 vdcw	76433	0140-0003	1	1		
C8	Capacitor: fixed, mica, 680 pf ±10%, 500 vdcw	00853	0140-0007	1	1		
C9 thru C100	Not assigned						

* See introduction to this section

Table 5-1 Replaceable Parts (Sheet 2 of 17)

Ckt Ref.	Description	Mfr *	Ⓟ Stock No.	TQ*	RS*		
C101	Capacitor: fixed, paper 6800 pf ±10%, 5000 vdcw	56289	0160-0045	6	2		
C102, 103	Capacitor: fixed, paper, 3 uf -10% +20%, 2000 vdcw	00853	0160-0083	2	1		
C104	Capacitor: fixed, electrolytic, 3 sections, 10 uf/section, 450 vdcw	37942	0180-0016	1	1		
C105	Capacitor: fixed, mylar, 0.22 uf ±10%, 200 vdcw	56289	0170-0038	3	1		
C106	Capacitor: fixed, mica, 560 pf ±10%, 500 vdcw	00853	0140-0044	1	1		
C107	Not assigned						
C108 thru C112	Same as C101						
C113	Capacitor: fixed, electrolytic, 50 uf -10% +20%, 50 vdcw	37942	0180-0029	1	1		
C114	Capacitor: fixed, ceramic, 100 pf ±5%, 4000 vdcw	91418	0150-0049	1	1		
C115	Capacitor: fixed, mica, 100 pf ±10%, 500 vdcw	00853	0140-0054	1	1		
C116	Capacitor: fixed, paper, 0.001 uf ±10%, 600 vdcw	56289	0160-0006	2	1		
C117	Capacitor: variable, mica, 50-380 pf, 175 vdcw	72136	0131-0001	1	1		
C118	Not assigned						
C119	Capacitor: fixed, electrolytic, 40 uf, 450 vdcw	56289	0180-0024	2	1		
C120	Capacitor: fixed, paper, 0.1 uf ±10%, 400 vdcw	56289	0160-0013	1	1		
C121	Same as C119						
C122	Capacitor: fixed, paper, 0.01 uf ±20%, 400 vdcw	56289	0160-0054	3	1		
C123, 124	Same as C105						
C125 thru C200	Not assigned						
C201	Capacitor: fixed, mylar, 4700 pf ±10%, 400 vdcw	84411	0170-0021	1	1		
C202	Not assigned						

* See introduction to this section

Table 5-1 Replaceable Parts (Sheet 3 of 17)

Ckt Ref.	Description	Mfr *	Stock No.	TQ*	RS*		
C203	Capacitor: fixed, mylar, 0.1 uf $\pm 5\%$, 200 vdcw	84411	0170-0019	5	2		
C204	Capacitor: fixed, mylar, 1 uf $\pm 5\%$, 200 vdcw	84411	0170-0018	3	1		
C205	Capacitor: fixed, mylar, 0.01 uf $\pm 5\%$, 400 vdcw	84411	0170-0017	4	1		
C206	Capacitor: fixed, mica, 10 pf $\pm 10\%$, 500 vdcw	76433	0140-0002	1	1		
C207	Capacitor: variable, mica, 170-780 pf, 175 vdcw	72136	0131-0003	2	1		
C208	Capacitor: fixed, mica, 270 pf $\pm 10\%$, 500 vdcw	00853	0140-0015	1	1		
C209	Capacitor: fixed, mica, 390 pf $\pm 10\%$, 500 vdcw	76433	0140-0030	1	1		
C210	Same as C207						
C211	Same as C205						
C212	Same as C203						
C213	Same as C204						
C214, 215	Same as C205						
C216	Capacitor: fixed, mylar, 10 uf $\pm 5\%$, 200 vdcw	72928	0170-0025	1	1		
C217 thru C219	Same as C203						
C220	Not assigned						
C221	Same as C116						
C222	Capacitor: fixed, mica, 68 pf $\pm 5\%$, 500 vdcw	00853	0140-0082	1	1		
C223	Capacitor: fixed, mylar, 0.1 uf $\pm 20\%$, 100 vdcw	56289	0170-0055	1	1		
C224	Same as C204						
C225 thru C300	Not assigned						
C301	Same as C122						
C302	Capacitor: fixed, paper, 1500 pf $\pm 10\%$, 600 vdcw	56289	0160-0012	1	1		

* See introduction to this section

Table 5-1 Replaceable Parts (Sheet 4 of 17)

Ckt Ref.	Description	Mfr *	hp Stock No.	TQ*	RS*		
C303	Same as C122						
C304	Capacitor: fixed, ceramic, 0.05 uf ±20%, 400 vdcw	56289	0150-0052	1	1		
CR1, 2	Diode, silicon: 1N1566A	04713	1901-0006	2	2		
CR3	Rectifier, selenium	77638	1883-0005	1	1		
CR4 thru CR100	Not assigned						
CR101	Rectifier, selenium	00891	1883-0006	1	1		
CR102 thru CR106	Diode, silicon: 1N2071	01295	1901-0012	7	7		
CR107 thru CR200	Not assigned						
CR201 thru CR203	Rectifier, crystal	73293	1910-0011	3	3		
CR204	Diode, silicon	28480	G-31G-56A	1	1		
CR205 thru CR300	Not assigned						
CR301	Diode, silicon	28480	G-29E-2	1	1		
CR302, 303	Same as CR102						
CR304	Diode, germanium: 1N90	73293	1910-0004	1	1		
DS1	Lamp, incandescent: 6-8V, 0.15 amp, #47	24455	2140-0009	1	1		
F1 thru F100	Not assigned						
F101, 102	Fuse: 3 amp, 3 AG 115 or 230V operation	75915	2110-0003	2	0		
J1 thru J100	Not assigned						
J101	RF output: Part of BWO tube assembly; not separately replaceable						
J102 thru J200	Not assigned						

* See introduction to this section

Table 5-1 Replaceable Parts (Sheet 5 of 17)

Ckt Ref.	Description	Mfr *	Stock No.	TQ*	RS*		
J201 thru J203	Connector, BNC	91737	1250-0001	4	1		
J204 thru J300	Not assigned						
J301	Same as J201						
K1 thru K100	Not assigned						
K101, 102	Relay armature: DPDT, 1.5 amps Delayed Turn-On Relay; Helix Overload Holdoff Relay	70119	0490-0008	2	1		
K103	Relay, armature: SPDT, 2 amps, Helix Overload Relay	77342	0490-0018	1	1		
L1	BWO Magnet	28480	9161-0006	1	1		
L2 thru L100	Not assigned						
L101	Inductor: 118 mh	98405	9140-0006	1	1		
M1 thru M100	Not assigned						
M101	Meter	28480	1120-0063	1	1		
R1, 2	Resistor: fixed, wirewound, 9 ohms $\pm 10\%$, 5 W	35434	0813-0016	4	1		
R3	Resistor: fixed, composition, 100 ohms $\pm 10\%$, 1/2 W	01121	0687-1011	4	1		
R4, 5	Resistor: fixed, composition, 47 ohms $\pm 10\%$, 2 W	01121	0693-4701	6	2		
R6, 7	Same as R3						
R8, 9	Same as R4						
R10	Same as R3						
R11	Resistor: fixed, composition, 220,000 ohms $\pm 10\%$, 1/2 W	01121	0687-2241	4	1		
R12, 13	Resistor: fixed, wirewound, 200 ohms $\pm 10\%$, 20 W Optimum value selected at factory. Average value shown.	83777	0819-0009	2	1		
R14 thru R17	Resistor: fixed, wirewound, 1000 ohms $\pm 5\%$, 40 W Optimum value selected at factory. Average value shown.	94310	0818-0014	4	1		

* See introduction to this section

Table 5-1 Replaceable Parts (Sheet 6 of 17)

Ckt Ref.	Description	Mfr *	Ⓢ Stock No.	TQ*	RS*		
R18, 19	Resistor: fixed, composition, 390,000 ohms $\pm 10\%$, 1/2 W	01121	0687-3941	4	1		
R20	Same as R4						
R21	Resistor: fixed, wirewound, 10,000 ohms $\pm 10\%$, 5 W	83777	0813-0007	2	1		
R22	Resistor: fixed, composition, 680,000 ohms $\pm 10\%$, 1/2 W	01121	0687-6841	4	1		
R23	Resistor: fixed, composition, 180,000 ohms $\pm 10\%$, 1/2 W	01121	0687-1841	3	1		
R24	Same as R22						
R25	Same as R23 Optimum value selected at factory. Average value shown.						
R26	Resistor: fixed, composition, 33,000 ohms $\pm 10\%$, 1/2 W	01121	0687-3331	3	1		
R27	Resistor: 0.073 ohms, Shunt "A"	28480	686A-26A	1	1		
R28	Resistor: fixed, wirewound, 14 ohms $\pm 10\%$, 10 W	35434	0816-0019	2	1		
R29	Resistor: fixed, composition, 15 megohms $\pm 10\%$, 1/2 W	01121	0687-1561	1	1		
R30	Resistor: variable, composition, linear taper, 500,000 ohms $\pm 30\%$, 1/4 W	71450	2100-0181	2	1		
R31	Same as R18						
R32	Resistor: fixed, composition, 39 ohms $\pm 10\%$, 2 W Optimum value selected at factory. Average value shown.	01121	0693-3901	1	1		
R33	Resistor: fixed, composition, 1 megohm $\pm 10\%$, 1/2 W	01121	0687-1051	10	3		
R34	Same as R23						
R35	Tube, ballast: #15-4	70563	0852-0008	1	1		
R36	Tube, ballast: Amperite #12-4	70563	0852-0001	1	1		
R37	Same as R4 Optimum value selected at factory. Average value shown.						

* See introduction to this section

Table 5-1 Replaceable Parts (Sheet 7 of 17)

Ckt Ref.	Description	Mfr *	hp Stock No.	TQ*	RS*		
R38	Resistor: fixed, composition, 100 ohms $\pm 10\%$, 2 W Optimum value selected at factory. Average value shown.	01121	0693-1011	1	1		
R39	Same as R28 Optimum value selected at factory. Average value shown.						
R40	Resistor: fixed, composition, 2.7 ohms $\pm 10\%$, 1 W Optimum value selected at factory. Average value shown.	01121	0699-0005	1	1		
R41, 42	Same as R1						
R43	Thermistor	24446	0839-0006	1	1		
R44 thru R100	Not assigned						
R101	Resistor: fixed, wirewound, 7500 ohms $\pm 10\%$, 10 W	35434	0816-0007	1	1		
R102	Resistor: fixed, composition, 100 ohms $\pm 10\%$, 1 W	01121	0690-1011	3	1		
R103	Resistor: fixed, composition, 2200 ohms $\pm 10\%$, 1 W	01121	0690-2221	2	1		
R104	Resistor: fixed, composition, 100,000 ohms $\pm 10\%$, 1 W	01121	0690-1041	1	1		
R105	Same as R102						
R106 thru R108	Resistor: fixed, composition, 1.8 megohms $\pm 10\%$, 2 W	01121	0693-1851	3	1		
R109, 110	Resistor: fixed, composition, 820,000 ohms $\pm 10\%$, 1 W	01121	0690-8241	2	1		
R111	Resistor: fixed, composition, 220 ohms $\pm 10\%$, 1/2 W	01121	0687-2211	1	1		
R112	Resistor: fixed, composition, 1800 ohms $\pm 10\%$, 1/2 W	01121	0687-1821	1	1		
R113	Same as R102						
R114	Not assigned						
R115	Resistor: fixed, composition, 39,000 ohms $\pm 10\%$, 1/2 W Optimum value selected at factory. Average value shown.	01121	0687-3931	1	1		

* See introduction to this section

Table 5-1 Replaceable Parts (Sheet 8 of 17)

Ckt Ref.	Description	Mfr *	Stock No.	TQ*	RS*		
R116 thru R119	Resistor: fixed, composition, 470,000 ohms $\pm 10\%$, 2 W	01121	0693-4741	8	2		
R120	Resistor: fixed, composition, 10 ohms $\pm 10\%$, 1 W	01121	0690-1001	1	1		
R121	Not assigned						
R122	Resistor: fixed, metal film, 450,000 ohms $\pm 5\%$, 1 W	15909	0761-0002	2	1		
R123	Resistor: 7.15 ohms, shunt "B"	28480	686A-26B	2	1		
R124, 125	Resistor: 50 ohms, shunt "C"	28480	686A-26C	2	1		
R126	Same as R123						
R127, 128	Resistor: fixed, composition, 1.5 megohms $\pm 10\%$, 1/2 W	01121	0687-1551	4	1		
R129, 130	Resistor: fixed, composition, 150,000 ohms $\pm 10\%$, 1/2 W	01121	0687-1541	4	1		
R131	Resistor: fixed, composition, 2200 ohms $\pm 10\%$, 1/2 W	01121	0687-2221	2	1		
R132	Resistor: variable, composition, linear taper, 3 megohms $\pm 20\%$, 1/4 W	71450	2100-0046	1	1		
R133	Resistor: fixed, composition, 330,000 ohms $\pm 10\%$, 1 W	01121	0690-3341	1	1		
R134	Resistor: fixed, composition, 68,000 ohms $\pm 10\%$, 1 W	01121	0690-6831	1	1		
R135	Resistor: variable, composition, linear taper, 500,000 ohms $\pm 10\%$, 2 W	01121	2100-0043	1	1		
R136	Not assigned						
R137	Resistor: fixed, composition, 15,000 ohms $\pm 10\%$, 1/2 W	01121	0687-1531	3	1		
R138	Resistor: fixed, composition, 180,000 ohms $\pm 10\%$, 2 W	01121	0693-1841	1	1		
R139	Same as R33						
R140	Resistor: fixed, composition, 120,000 ohms $\pm 10\%$, 1/2 W	01121	0687-1241	2	1		
R141	Resistor: variable, composition, 50,000 ohms $\pm 30\%$, 1/4 W	71450	2100-0094	2	1		

* See introduction to this section

Table 5-1 Replaceable Parts (Sheet 9 of 17)

Ckt Ref.	Description	Mfr *	Ⓟ Stock No.	TQ*	RS*		
R142	Resistor: fixed, composition, 270,000 ohms $\pm 10\%$, 1/2 W	01121	0687-2741	2	1		
R143	Same as R26						
R144	Resistor: fixed, composition, 47,000 ohms $\pm 10\%$, 1/2 W	01121	0687-4731	2	1		
R145	Resistor: fixed, wirewound, 20,000 ohms $\pm 10\%$, 10 W	35434	0816-0018	1	1		
R146	Resistor: fixed, composition, 470,000 ohms $\pm 10\%$, 1/2 W	01121	0687-4741	3	1		
R147	Resistor: fixed, composition, 100,000 ohms $\pm 10\%$, 1/2 W	01121	0687-1041	5	2		
R148	Same as R141						
R149	Resistor: fixed, composition, 56,000 ohms $\pm 10\%$, 1/2 W	01121	0687-5631	1	1		
R150	Resistor: fixed, deposited carbon, 600,000 ohms $\pm 5\%$, 1 W	19701	0730-0095	2	1		
R151	Same as R122						
R152	Resistor: fixed, composition, 10 megohms $\pm 10\%$, 1/2 W	01121	0687-1061	1	1		
R153	Resistor: fixed, composition, 22 megohms $\pm 10\%$, 1/2 W	01121	0687-2261	3	1		
R154	Same as R150						
R155 thru R157	Not assigned						
R158	Resistor: fixed, composition, 150,000 ohms $\pm 10\%$, 2 W	01121	0693-1541	1	1		
R159 thru R165	Not assigned						
R166	Resistor: fixed, composition, 47 ohms $\pm 10\%$, 1 W	01121	0690-4701	2	1		
R167, 168	Same as R116						
R169	Same as R166						
R170, 171	Same as R116						
R172 thru R174	Not assigned						

* See introduction to this section

Table 5-1 Replaceable Parts (Sheet 10 of 17)

Ckt Ref.	Description	Mfr *	hp Stock No.	TQ*	RS*		
R175	Resistor: fixed, composition, 47,000 ohms $\pm 10\%$, 1 W	01121	0690-4731	1	1		
R176 thru R200	Not assigned						
R201	Same as R153						
R202	Resistor: fixed, composition, 8.2 megohms $\pm 10\%$, 1/2 W	01121	0687-8251	1	1		
R203	Same as R30						
R204	Same as R33						
R205	Resistor: fixed, composition, 3.3 megohms $\pm 10\%$, 1/2 W	01121	0687-3351	2	1		
R206	Same as R137						
R207	Resistor: fixed, composition, 6800 ohms $\pm 10\%$, 1/2 W	01121	0687-6821	1	1		
R208	Resistor: fixed, composition, 1500 ohms $\pm 10\%$, 1/2 W	01121	0687-1521	2	1		
R209	Resistor: fixed, composition, 27,000 ohms $\pm 5\%$, 1/2 W	01121	0686-2735	1	1		
R210	Resistor: fixed, metal film, 600,000 ohms $\pm 1/2\%$, 1/2 W	65092	0757-0016	1	1		
R211	Resistor: fixed, deposited carbon, 1.5 megohms $\pm 1\%$, 1/2 W	19701	0727-0282	1	1		
R212	Resistor: fixed, deposited carbon, 265,000 ohms $\pm 1\%$, 1/2 W Optimum value selected at factory. Average value shown.	19701	0727-0229	1	1		
R213	Resistor: fixed, deposited carbon, 1.75 ohms $\pm 1\%$, 1/2 W	19701	0727-0284	1	1		
R214	Same as R147						
R215	Same as R33						
R216	Resistor: fixed, composition, 150,000 ohms $\pm 10\%$, 1 W	01121	0690-1541	2	1		
R217	Resistor: variable, composition, linear taper, 1 megohm $\pm 30\%$, 0.2 W	71450	2100-0080	4	1		
R218	Resistor: fixed, composition, 560,000 ohms $\pm 10\%$, 1/2 W	01121	0687-5641	1	1		
R219	Same as R22						

* See introduction to this section

Table 5-1 Replaceable Parts (Sheet 11 of 17)

Ckt Ref.	Description	Mfr *	Ⓢ Stock No.	TQ*	RS*		
R220	Same as R147						
R221	Same as R142						
R222	Same as R140						
R223, 224	Resistor: fixed, composition, 10,000 ohms $\pm 10\%$, 1/2 W	01121	0687-1031	3	1		
R225 thru R227	Resistor: variable, composition, linear taper, 50,000 ohms $\pm 20\%$, 1/4 W	71450	2100-0141	3	1		
R228	Resistor: fixed, composition, 27,000 ohms $\pm 10\%$, 1/2 W	01121	0687-2731	1	1		
R229	Resistor: variable, composition, 5 megohms -0% +100%, 1/4 W	71450	2100-0066	1	1		
R230	Resistor: fixed, deposited carbon, 4.9 megohms $\pm 1\%$, 1/2 W	19701	0727-0299	1	1		
R231	Resistor: fixed, deposited carbon, 15.7 megohms $\pm 1\%$, 1 W	95236	0730-0146	1	1		
R232	Same as R205 Optimum value selected at factory. Average value shown.						
R233	Resistor: fixed, composition, 12,000 ohms $\pm 10\%$, 1/2 W	01121	0687-1231	1	1		
R234	Resistor: fixed, deposited carbon, 41,500 ohms $\pm 1\%$, 1 W Optimum value selected at factory. Average value shown.	19701	0730-0050	1	1		
R235	Same as R21						
R236	Resistor: variable, wirewound, linear taper, 100,000 ohms $\pm 5\%$, 8 W	99957	2100-0042	1	1		
R237	Same as R127						
R238	Same as R33						
R239	Same as R18						
R240	Resistor: fixed, deposited carbon, 115,000 ohms $\pm 1\%$, 1/2 W	19701	0727-0213	1	1		
R241	Same as R208 Optimum value selected at factory. Average value shown.						
R242	Same as R33						
R243	Resistor: fixed, composition, 270,000 ohms $\pm 10\%$, 1 W	01121	0690-2741	1	1		

* See introduction to this section

Table 5-1 Replaceable Parts (Sheet 12 of 17)

Ckt Ref.	Description	Mfr *	Ⓢ Stock No.	TQ*	RS*		
R244	Resistor: variable, composition, linear taper, 200,000 ohms $\pm 30\%$, 1/4 W	71450	2100-0164	1	1		
R245	Same as R217						
R246	Resistor: variable, composition, linear taper, 3 megohms $\pm 30\%$, 1/4 W	71450	2100-0165	2	1		
R247	Resistor: variable, composition, linear taper, 10 megohms $\pm 30\%$, 1/4 W	71450	2100-0040	2	1		
R248	Same as R217						
R249	Same as R246						
R250	Same as R247						
R251	Same as R217						
R252	Same as R146						
R253	Same as R127						
R254	Resistor: fixed, composition, 1.2 megohms $\pm 10\%$, 1/2 W Optimum value selected at factory. Average value shown.	01121	0687-1251	1	1		
R255	Resistor: fixed, composition, 5.6 megohms $\pm 10\%$, 1/2 W	01121	0687-5651	1	1		
R256	Resistor: fixed, composition, 4.7 megohms $\pm 10\%$, 1/2 W Optimum value selected at factory. Average value shown.	01121	0687-4751	1	1		
R257	Same as R147						
R258	Same as R131						
R259	Resistor: fixed, deposited carbon, 46.74 megohms $\pm 1\%$, 2 W	19701	0733-0011	1	1		
R260	Resistor: fixed, composition, 130,000 ohms $\pm 5\%$, 1/2 W	01121	0686-1345	1	1		
R261, 262	Resistor: fixed, composition, 39,000 ohms $\pm 10\%$, 1/2 W	01121	0687-3931	2	1		
R263	Resistor: fixed, composition, 200,000 ohms $\pm 5\%$, 1/2 W	01121	0686-2045	1	1		
R264	Same as R146						
R265 thru R300	Not assigned						

* See introduction to this section

Table 5-1 Replaceable Parts (Sheet 13 of 17)

Ckt Ref.	Description	Mfr *	Ⓜ Stock No.	TQ*	RS*		
R301	Same as R153						
R302	Resistor: variable, composition, 3.5 megohms $\pm 20\%$, 2 W	71450	2100-0162	1	1		
R303	Resistor: fixed, composition, 100,000 ohms $\pm 5\%$, 1/2 W	01121	0686-1045	2	1		
R304	Same as R103						
R305	Same as R216						
R306	Resistor: fixed, composition, 2.2 megohms $\pm 10\%$, 1 W	01121	0690-2251	1	1		
R307	Resistor: fixed, composition, 1.2 megohms $\pm 10\%$, 1 W	01121	0690-1251	1	1		
R308	Resistor: fixed, composition, 12,000 ohms $\pm 10\%$, 1 W	01121	0690-1231	1	1		
R309	Resistor: fixed, composition, 680,000 ohms $\pm 10\%$, 1 W	01121	0690-6841	1	1		
R310	Resistor: variable, composition, linear taper, 1 megohm $\pm 30\%$, 1/4 W	71450	2100-0096	3	1		
R311	Resistor: fixed, composition, 1.5 megohms $\pm 10\%$, 1 W	01121	0690-1551	1	1		
R312	Same as R33						
R313	Resistor: fixed, composition, 750,000 ohms $\pm 5\%$, 1/2 W Optimum value selected at factory. Average value shown.	01121	0686-7545	1	1		
R314	Not assigned						
R315	Same as R310						
R316	Same as R33						
R317	Same as R223						
R318	Resistor: fixed, composition, 82,000 ohms $\pm 10\%$, 1 W Optimum value selected at factory. Average value shown.	01121	0690-8231	1	1		
R319	Same as R26						
R320	Resistor: variable, composition, 20,000 ohms $\pm 20\%$, 1/4 W	71450	2100-0093	1	1		
R321	Same as R310						
R322	Same as R129						

* See introduction to this section

Table 5-1 Replaceable Parts (Sheet 14 of 17)

Ckt Ref.	Description	Mfr *	Ⓜ Stock No.	TQ*	RS*		
R323	Resistor: fixed, composition, 68,000 ohms ±10%, 1/2 W	01121	0687-6831	2	1		
R324	Resistor: variable, composition, 100,000 ohms ±30%, 1/4 W	71450	2100-0095	2	1		
R325	Same as R144						
R326	Same as R303						
R327	Part of S302; component not separately replaceable						
R328	Not assigned						
R329	Same as R22						
R330	Resistor: fixed, composition, 220,000 ohms ±10%, 2 W	01121	0693-2241	1	1		
R331	Same as R147						
R332	Same as R324						
R333	Same as R137						
R334	Resistor: fixed, composition, 68,000 ohms ±10%, 2 W	01121	0693-6831	1	1		
R335	Resistor: variable, composition, linear taper, 250,000 ohms ±30%, 1/4 W	71450	2100-0144	1	1		
R336	Same as R323						
R337	Same as R11						
R338, 339	Same as R33						
R340	Same as R129						
R341, 342	Same as R11						
S1 thru S100	Not assigned						
S101	Switch, toggle: SPDT	04009	3101-0030	1	1		
S102	Thermal Delay Switch: SPST	70563	0490-0019	1	1		
S103	Switch, rotary: 2 section, 5 position	71590	3100-0161	1	1		
S104 thru S200	Not assigned						

* See introduction to this section

Table 5-1 Replaceable Parts (Sheet 15 of 17)

Ckt Ref.	Description	Mfr *	Ⓟ Stock No.	TQ*	RS*		
S201	Switch, push: SPDT (manual trigger)	82389	3101-0004	1	1		
S202	Switch, rotary: (sweep selector)	76854	3100-0163	1	1		
S203	Switch, rotary: (sweep time)	76854	3100-0160	1	1		
S204	Switch, rotary: (sweep rate)	76854	3100-0162	1	1		
S205 thru S300	Not assigned						
S301	Switch, rotary	76854	3100-0258	1	1		
S302	Switch, rotary, with 1 megohm potentiometer	76854	3100-0135	1	1		
T1	Transformer, power (low voltage)	28480	9100-0086	1	1		
T2 thru T100	Not assigned						
T101	Transformer, power (high voltage)	28480	9100-0085	1	1		
V1, 2	Tube, electron: 6080	80131	1932-0010	2	2		
V3	Tube, electron: OA2	80131	1940-0004	2	2		
V4	Tube, electron: 6DJ8/ECC88	80131	1932-0022	7	7		
V5	Tube, electron: 12AX7	80131	1932-0030	1	1		
V6 thru V11	Lamp, neon: selected, aged & tested NE2 (blue)	28480	G-84B	8	8		
V12 thru V100	Not assigned						
V101	Tube, electron: 6293	80131	1923-0007	1	1		
V102	Tube, electron: 6350	80131	1932-0013	1	1		
V103	Tube, electron: 7239	80131	1923-0045	1	1		
V104	Tube, BWO	05783	1951-0013	1	1		
	Spec. H01-686A only- Tube, BWO	05783	1951-0015	1	1		
V105	Tube, electron: 12AT7	80131	1932-0027	1	1		
V106	Tube, electron: 12B4A	80131	1921-0010	1	1		

* See introduction to this section

Table 5-1 Replaceable Parts (Sheet 16 of 17)

Ckt Ref.	Description	Mfr *	Ⓢ Stock No.	TQ*	RS*		
V107	Tube, electron: 6U8	80131	1933-0004	3	3		
V108	Tube, electron: 5651	80131	1940-0001	1	1		
V109	Same as V107						
V110	Lamp, neon: selected, aged & tested NE2 (red)	28480	G-84E	2	2		
V111 thru V200	Not assigned						
V201, 202	Same as V4						
V203	Tube, electron: 6AL5	80131	1930-0013	2	2		
V204	Tube, electron: 6AN8	80131	1933-0001	1	1		
V205	Same as V203						
V206	Same as V3						
V207	Same as V4						
V208	Same as V107						
V209, 210	Same as V6						
V211	Same as V110						
V212 thru V300	Not assigned						
V301 thru V303	Same as V4						
W101	Cable, power	70903	8120-0015	1	1		
	<u>MISCELLANEOUS</u>						
	Ceramic plate cap: 3/8"	76487	1401-0006	1	1		
	Ceramic plate cap: 1/4"	76487	1401-0007	1	1		
	Cronac spring	0000C	1460-0005	1	1		
	Filter, air	82866	3150-0005	1	1		
	Fuseholder	75915	1400-0056	1	1		
	Fuseholder	75915	1400-0084	1	1		
	Knob: CATHODE CURRENT	28480	G-74L	1	0		

* See introduction to this section

Table 5-1 Replaceable Parts (Sheet 17 of 17)

Ckt Ref.	Description	Mfr *	Ⓢ Stock No.	TQ*	RS*		
	Knob, bar: CURRENT, SWEEP SELECTOR RF SWEEP RATE	28480	G-74N	3	0		
	Knob, bar: AMPL. MOD. SELECTOR, Δ FREQUENCY (MC)	28480	G-74Q	2	0		
	Knob: FREQUENCY DIAL	28480	G-74Z	1	0		
	Knob: FREQUENCY VERNIER	28480	G-74F	1	0		
	Knob, red: RF LEVELER	28480	G-74AT	1	0		
	Knob, red: INT SQUARE WAVE FREQUENCY, Δ FREQUENCY (MC) VERNIER	28480	G-74AV	2	0		
	Lampholder	95263	1450-0008	1	1		
	Pre-calibrated Dial	28480	686A-40A	1	0		
	Socket (BWO supply)	0000L	1251-0044	1	1		
	Tube socket: (V105)	71785	1200-0003	1	1		
	Tube socket: (V4, V107, V301, V5, V109, V302, V102, V201, V303) V103, V202, V104, V204, V106, V207,	71785	1200-0008	15	1		
	Tube socket: (V3, V203, V206) V108, V205,	91662	1200-0009	5	1		
	Tube socket: (V1, V101, R35, V2, R36)	71785	1200-0020	5	1		
	Tube clamp	91506	1400-0032	5	0		
	Tube clamp holder (small)	92196	1400-0034	15	0		
	Tube clamp holder (large)	92196	1400-0035	5	0		
	Vernier drive disc and shaft	28480	G-14A	1	0		
	Vernier drive disc	28480	G-14B	1	0		
	Vernier spring	0000C	1460-0019	1	0		
	Window, dial	28480	G-99K	1	0		

* See introduction to this section

APPENDIX

CODE LIST OF MANUFACTURERS (Sheet 1 of 2)

The following code numbers are from the Federal Supply Code for Manufacturers Cataloging Handbooks H4-1 (Name to Code) and H4-2 (Code to Name) and their latest supplements. The date of revision and the date of the supplements used appear at the bottom of each page. Alphabetical codes have been arbitrarily assigned to suppliers not appearing in the H4 handbooks.

CODE NO.	MANUFACTURER	ADDRESS	CODE NO.	MANUFACTURER	ADDRESS	CODE NO.	MANUFACTURER	ADDRESS
00334	Humidial Co.	Colton, Calif.	09250	Electro Assemblies, Inc.	Chicago, Ill.	71218	Bud Radio Inc.	Cleveland, Ohio
00335	Westrex Corp.	New York, N.Y.	10411	Ti-Tal, Inc.	Berkeley, Calif.	71286	Camloc Fastener Corp.	Paramus, N.J.
00373	Garlock Packing Co., Electronic Products Div.	Camden, N.J.	10646	Carborundum Co.	Niagara Falls, N.Y.	71313	Allen D. Cardwell Electronic Prod. Corp	Plainville, Conn.
00656	Aerovox Corp.	New Bedford, Mass.	11237	Chicago Telephone of California, Inc.	So. Pasadena, Calif.	71400	Bussmann Fuse Div. of McGraw- Edison Co.	St. Louis, Mo.
00779	Amp, Inc.	Harrisburg, Pa.	12697	Clarostat Mfg. Co.	Dover, N.H.	71450	Chicago Telephone Supply Co.	Elkhart, Ind.
00781	Aircraft Radio Corp.	Boonton, N.J.	14655	Cornell Dubilier Elec. Corp.	So. Plainfield, N.J.	71468	Cannon Electric Co.	Los Angeles, Calif.
00853	Sangamo Electric Co., Cap. Div.	Marion, Ill.	15909	The Daven Co.	Livingston, N.J.	71471	Cinema Engineering Co.	Burbank, Calif.
00866	Goe Engineering Co.	Los Angeles, Calif.	16758	Delco Radio Div. of G. M. Corp.	Kokomo, Ind.	71482	C. P. Clare & Co.	Chicago, Ill.
01561	Carl E. Holmes Corp.	Los Angeles, Calif.	18873	E. I. DuPont and Co., Inc.	Wilmington, Del.	71590	Centralab Div. of Globe Union Inc.	Milwaukee, Wis.
01121	Allen Bradley Co.	Milwaukee, Wis.	19315	Eclipse Pioneer, Div. of Bendix Aviation Corp.	Teterboro, N.J.	71700	The Cornish Wire Co.	New York, N.Y.
01255	Litton Industries, Inc.	Beverly Hills, Calif.	19500	Thomas A. Edison Industries, Div. of McGraw-Edison Co.	West Orange, N.J.	71744	Chicago Miniature Lamp Works	Chicago, Ill.
01281	Pacific Semiconductors, Inc.	Culver City, Calif.	19701	Electra Manufacturing Co.	Kansas City, Mo.	71753	A. O. Smith Corp., Crowley Div.	West Orange, N.J.
01295	Texas Instruments, Inc. Semiconductor Components Div.	Dallas, Texas	20183	Electronic Tube Corp.	Philadelphia, Pa.	71785	Cinch Mfg. Corp.	Chicago, Ill.
01349	The Alliance Mfg. Co.	Alliance, Ohio	21520	Fansteel Metallurgical Corp.	No. Chicago, Ill.	71984	Dow Corning Corp.	Midland, Mich.
01561	Chassi-Trak Corp.	Indianapolis, Ind.	21335	The Fafnir Bearing Co.	New Britain, Conn.	72136	Electro Motive Mfg. Co., Inc.	Willimantic, Conn.
01961	Pulse Engineering Co.	Santa Clara, Calif.	21964	Fed. Telephone and Radio Corp.	Clifton, N.J.	72354	John E. Fast & Co.	Chicago, Ill.
02114	Ferrocube Corp. of America	Saugerties, N.Y.	24446	General Electric Co.	Schenectady, N.Y.	72619	Dialight Corp.	Brooklyn, N.Y.
02286	Cole Mfg. Co.	Palo Alto, Calif.	24455	G. E., Lamp Division	Nela Park, Cleveland, Ohio	72656	General Ceramics Corp.	Keasbey, N.J.
02660	Amphenol Electronics Corp.	Chicago, Ill.	24655	General Radio Co.	West Concord, Mass.	72758	Girard-Hopkins	Oakland, Calif.
02735	Radio Corp. of America Semiconductor and Materials Div.	Somerville, N.J.	26462	Grobet File Co. of America, Inc.	Carlstadt, N.J.	72765	Drake Mfg. Co.	Chicago, Ill.
02777	Hopkins Engineering Co.	San Fernando, Calif.	26992	Hamilton Watch Co.	Lancaster, Pa.	72825	Hugh H. Eby Inc.	Philadelphia, Pa.
03508	G.E. Semiconductor Products Dept.	Syracuse, N.Y.	28480	Hewlett-Packard Co.	Palo Alto, Calif.	72928	Gudeman Co.	Chicago, Ill.
03705	Apex Machine & Tool Co.	Dayton, Ohio	33173	G. E. Receiving Tube Dept.	Owensboro, Ky.	72982	Erie Resistor Corp.	Erie, Pa.
03797	Eldema Corp.	El Monte, Calif.	35434	Lectrohm Inc.	Chicago, Ill.	73061	Hansen Mfg. Co., Inc.	Princeton, Ind.
03877	Transitron Electronic Corp.	Wakefield, Mass.	37942	P. R. Mallory & Co., Inc.	Indianapolis, Ind.	73138	Helipot Div. of Beckman Instruments, Inc.	Fullerton, Calif.
04009	Arrow, Hart and Hegeman Elect. Co.	Hartford, Conn.	39543	Mechanical Industries Prod. Co.	Akron, Ohio	73293	Hughes Products Div. of Hughes Aircraft Co.	Newport Beach, Calif.
04062	Elmenco Products Co.	New York, N.Y.	40920	Miniature Precision Bearings, Inc.	Keene, N.H.	73445	Amperex Electronic Co., Div. of North American Phillips Co., Inc.	Hicksville, N.Y.
04222	Hi-Q Division of Aerovox	Myrtle Beach, S.C.	42190	Muter Co.	Chicago, Ill.	73506	Bradley Semiconductor Corp.	New Haven, Conn.
04404	Dymec Inc.	Palo Alto, Calif.	43990	C. A. Norgren Co.	Englewood, Colo.	73559	Carling Electric, Inc.	Hartford, Conn.
04651	Special Tube Operations of Sylvania Electronic Systems	Mountain View, Calif.	44655	Ohmite Mfg. Co.	Skokie, Ill.	73682	George K. Garrett Co., Inc.	Philadelphia, Pa.
04713	Motorola, Inc., Semiconductor Prod. Div.	Phoenix, Arizona	47904	Polaroid Corp.	Cambridge, Mass.	73743	Fischer Special Mfg. Co.	Cincinnati, Ohio
04732	Filtron Co., Inc. Western Division	Culver City, Calif.	48620	Precision Thermometer and Inst. Co.	Philadelphia, Pa.	73793	The General Industries Co.	Elyria, Ohio
04777	Automatic Electric Sales Corp.	Northlake, Ill.	49956	Raytheon Mfg. Co.	Waltham, Mass.	73905	Jennings Radio Mfg. Co.	San Jose, Calif.
05006	Twentieth Century Plastics, Inc.	Los Angeles, Calif.	54294	Shallcross Mfg. Co.	Salma, N.C.	74455	J. H. Winns, and Sons	Winchester, Mass.
05277	Westinghouse Electric Corp., Semi-Conductor Dept.	Youngwood, Pa.	55026	Simpson Electric Co.	Chicago, Ill.	74861	Industrial Condenser Corp.	Chicago, Ill.
05624	Barber Colman Co.	Rockford, Ill.	55933	Sonotone Corp.	Elmsford, N.Y.	74868	Industrial Products Co.	Danbury, Conn.
05783	Stewart Engineering Co.	Soquel, Calif.	55938	Sorenson & Co., Inc.	So. Norwalk, Conn.	74970	E. F. Johnson Co.	Waseca, Minn.
06004	The Bassick Co.	Bridgeport, Conn.	56137	Spaulding Fibre Co., Inc.	Tonawanda, N.Y.	75042	International Resistance Co.	Philadelphia, Pa.
06812	Torrington Mfg. Co., West. Div.	Van Nuys, Calif.	56289	Sprague Electric Co.	North Adams, Mass.	75173	Jones, Howard B., Division of Cinch Mfg. Corp.	Chicago, Ill.
07115	Corning Glass Works Electronic Components Dept.	Bradford, Pa.	59446	Telex, Inc.	St. Paul, Minn.	75378	James Knights Co.	Sandwich, Ill.
07137	Transistor Electronics Corp.	Minneapolis, Minn.	61775	Union Switch and Signal, Div. of Westinghouse Air Brake Co.	Pittsburgh, Pa.	75382	Kulka Electric Mfg. Co., Inc.	Mt. Vernon, N.Y.
07261	Avnet Corp.	Los Angeles, Calif.	62119	Universal Electric Co.	Owosso, Mich.	75818	Lenz Electric Mfg. Co.	Chicago, Ill.
07263	Fairchild Semiconductor Corp.	Mountain View, Calif.	64959	Western Electric Co., Inc.	New York, N.Y.	75915	Littelfuse Inc.	Des Plaines, Ill.
07933	Rheem Semiconductor Corp.	Mountain View, Calif.	65092	Weston Inst. Div. of Daystrom, Inc.	Newark, N.J.	76005	Lord Mfg. Co.	Erie, Pa.
07980	Boonton Radio Corp.	Boonton, N.J.	66346	Wollensak Optical Co.	Rochester, N.Y.	76210	C. W. Marwedel	San Francisco, Calif.
08718	Cannon Electric Co. Phoenix Div.	Phoenix, Ariz.	70119	Advance Electric and Relay Co.	Burbank, Calif.	76433	Micamold Electronic Mfg. Corp.	Brooklyn, N.Y.
08792	CBS Electronics Semiconductor Operations, Div. of C.B.S. Inc.	Lowell, Mass.	70276	Allen Mfg. Co.	Hartford, Conn.	76487	James Millen Mfg. Co., Inc.	Malden, Mass.
09134	Texas Capacitor Co.	Houston, Texas	70309	Allied Control Co., Inc.	New York, N.Y.	76530	Monadnock Mills	San Leandro, Calif.
			70485	Atlantic India Rubber Works, Inc.	Chicago, Ill.	76545	Mueller Electric Co.	Cleveland, Ohio
			70563	Amperite Co., Inc.	New York, N.Y.	76854	Oak Manufacturing Co.	Chicago, Ill.
			70903	Belden Mfg. Co.	Chicago, Ill.	77068	Bendix Corp., Bendix Pacific Div.	No. Hollywood, Calif.
			70998	Bird Electronic Corp.	Cleveland, Ohio	77221	Phoastron Instrument and Electronic Co.	South Pasadena, Calif.
			71002	Birnbach Radio Co.	New York, N.Y.	77342	Potter and Brumfield, Inc.	Princeton, Ind.

From: F.S.C. Handbook Supplements
H4-1 Dated Oct. 1960
H4-2 Dated Oct. 1960

00015-6
Revised: 13 April 1961

APPENDIX

CODE LIST OF MANUFACTURERS (Sheet 2 of 2)

CODE NO.	MANUFACTURER	ADDRESS	CODE NO.	MANUFACTURER	ADDRESS	CODE NO.	MANUFACTURER	ADDRESS
77630	Radio Condenser Co.	Camden, N.J.	84396	A. J. Giesener Co., Inc.	San Francisco, Calif.	97539	Automatic and Precision Mfg. Co.	Yonkers, N.Y.
77634	Radio Essentials Inc.	Mt. Vernon, N.Y.	84411	Good All Electric Mfg. Co.	Ogallala, Neb.	97966	CBS Electronics, Div. of C.B.S., Inc.	Danvers, Mass.
77638	Radio Receptor Co., Inc.	Brooklyn, N.Y.	84970	Sarkes Tarzian, Inc.	Bloomington, Ind.	98141	Axel Brothers Inc.	Jamaica, N.Y.
77764	Resistance Products Co.	Harrisburg, Pa.	85474	R. M. Bracamonte & Co.	San Francisco, Calif.	98220	Francis L. Mosley	Pasadena, Calif.
78283	Signal Indicator Corp.	New York, N.Y.	85660	Koiled Kords, Inc.	New Haven, Conn.	98278	Microdot, Inc.	So. Pasadena, Calif.
78471	Tilley Mfg. Co.	San Francisco, Calif.	85911	Seamless Rubber Co.	Chicago, Ill.	98291	Sealectro Corp.	New Rochelle, N.Y.
78488	Stackpole Carbon Co.	St. Marys, Pa.	86684	Radio Corp. of America, RCA Electron Tube Div.	Harrison, N.J.	98405	Carad Corp.	Redwood City, Calif.
78790	Transformer Engineers	Pasadena, Calif.	88140	Cutler-Hammer, Inc.	Lincoln, Ill.	98734	Palo Alto Engineering Co., Inc.	Palo Alto, Calif.
79142	Veeder Root, Inc.	Hartford, Conn.	89473	General Electric Distributing Corp.	Schenectady, N.Y.	98925	Clevite Transistor Prod. Div. of Clevite Corp.	Waltham, Mass.
79251	Wenco Mfg. Co.	Chicago, Ill.	90179	U.S. Rubber Co., Mechanical Goods Div.	Passaic, N.J.	98978	International Electronic Research Corp.	Burbank, Calif.
79963	Zierick Mfg. Corp.	New Rochelle, N.Y.	90970	Bearing Engineering Co.	San Francisco, Calif.	99109	Columbia Technical Corp.	New York, N.Y.
80130	Times Facsimile Corp.	New York, N.Y.	91418	Radio Materials Co.	Chicago, Ill.	99313	Varian Associates	Palo Alto, Calif.
80131	Electronic Industries Association Any brand tube meeting EIA standards	Washington, D.C.	91506	Augat Brothers, Inc.	Attleboro, Mass.	99800	Delevan Electronics Corp.	East Aurora, N.Y.
80248	Oxford Electric Corp.	Chicago, Ill.	91637	Dale Products, Inc.	Columbus, Neb.	99821	North Hills Electric Co.	Great Neck, L.I., N.Y.
80411	Acro Manufacturing Co.	Columbus, Ohio	91662	Elco Corp.	Philadelphia, Pa.	99848	Wilco Corporation	Indianapolis, Ind.
80486	All Star Products Inc.	Defiance, Ohio	91737	Gremer Mfg. Co., Inc.	Wakefield, Mass.	99934	Renbrandt, Inc.	Boston, Mass.
80583	Hammerlund Co., Inc.	New York, N.Y.	91827	K F Development Co.	Redwood City, Calif.	99942	Hoffman Semiconductor Div. of Hoffman Electronics, Corp.	Evansville, Ill.
80640	Stevens, Arnold, Co., Inc.	Boston, Mass.	91929	Micro-Switch Div. of Minneapolis Honeywell Regulator Co.	Freeport, Ill.	99957	Technology Instruments Corp. of Calif.	No. Hollywood, Calif.
81030	International Instruments, Inc.	New Haven, Conn.	92196	Universal Metal Products, Inc.	Bassett Puente, Calif.			
81415	Wilkor Products, Inc.	Cleveland, Ohio	93332	Sylvania Electric Prod. Inc., Semiconductor Div.	Woburn, Mass.			
81453	Raytheon Mfg. Co., Industrial Tube Division	Quincy, Mass.	93369	Robbins and Myers, Inc.	New York, N.Y.			
81483	International Rectifier Corp.	El Segundo, Calif.	93410	Stevens Mfg. Co., Inc.	Mansfield, Ohio			
81860	Barry Controls, Inc.	Watertown, Mass.	93983	Insuline-Van Norman Ind., Inc. Electronic Division	Manchester, N.H.			
82042	Carter Parts Co.	Skokie, Ill.	94144	Raytheon Mfg. Co., Receiving Tube Div.	Quincy, Mass.			
82142	Jeffers Electronics Division of Speer Carbon Co.	Du Bois, Pa.	94145	Raytheon Mfg. Co., Semiconductor Div.	Newton, Mass.			
82170	Allen B. DuMont Labs., Inc.	Clifton, N.J.	94154	Tung-Sol Electric, Inc.	Newark, N.J.			
82209	Maguire Industries, Inc.	Greenwich, Conn.	94197	Curtiss-Wright Corp., Electronics Div.	Carlstadt, N.J.			
82219	Sylvania Electric Prod. Inc., Electronic Tube Div.	Emporium, Pa.	94310	Tru Ohm Prod. Div. of Model Engineering and Mfg. Co.	Chicago, Ill.			
82376	Astron Co.	East Newark, N.J.	95236	Allies Products Corp.	Miami, Fla.			
82389	Switchcraft, Inc.	Chicago, Ill.	95238	Continental Connector Corp.	Woodside, N.Y.			
82647	Texas Instruments, Inc., Metals and Controls Div., Spencer Products	Attleboro, Mass.	95263	Leecraft Mfg. Co., Inc.	New York, N.Y.			
82866	Research Products Corp.	Madison, Wis.	95265	National Coil Co.	Sheridan, Wyo.			
82893	Vector Electronic Co.	Glendale, Calif.	95987	Weckesser Co.	Chicago, Ill.			
83148	Electro Cords Co.	Los Angeles, Calif.	96067	Huggins Laboratories	Sunnyvale, Calif.			
83186	Victory Engineering Corp.	Union, N.J.	96095	Hi-Q Division of Aerovox	Olean, N.Y.			
83298	Bendix Corp., Red Bank Div.	Red Bank, N.J.	96296	Solar Manufacturing Co.	Los Angeles, Calif.			
83594	Burroughs Corp., Electronic Tube Div.	Plainfield, N.J.	96341	Microwave Associates, Inc.	Burlington, Mass.			
83777	Model Eng. and Mfg., Inc.	Huntington, Ind.	96501	Excel Transformer Co.	Oakland, Calif.			
83821	Loyd Scruggs Co.	Festus, Mo.						
84171	Arco Electronics, Inc.	New York, N.Y.						

THE FOLLOWING H.P. VENDORS HAVE NO NUMBER ASSIGNED IN THE LATEST SUPPLEMENT TO THE FEDERAL SUPPLY CODE FOR MANUFACTURERS HANDBOOK.

0000C	Connor Spring Mfg. Co.	San Francisco, Calif.
0000D	Connex Corp.	Oakland, Calif.
0000E	Fisher Switches, Inc.	San Francisco, Calif.
0000F	Malco Tool and Die	Los Angeles, Calif.
0000G	Microwave Engineering Co.	Palo Alto, Calif.
0000H	Philco Corp. (Lansdale Division)	Lansdale, Pa.
0000I	Telefunken (c/o American Elite)	New York, N.Y.
0000L	Winchester Electronics, Inc.	Santa Monica, Calif.
0000M	Western Coil Div. of Automatic Ind., Inc.	Redwood City, Calif.
0000N	Nahm-Bros. Spring Co.	San Leandro, Calif.
0000P	Ty-Car Mfg. Co., Inc.	Holliston, Mass.
0000R	Metro Cap. Div., Metropolitan Telecommunications Corp.	Brooklyn, N.Y.
0000S	Moulton Electronics	San Carlos, Calif.



00015-6
Revised: 13 April 1961



From: F.S.C. Handbook Supplements
H4-1 Dated Oct. 1960
H4-2 Dated Oct. 1960



**BACKWARD WAVE OSCILLATOR TUBE WARRANTY CLAIMS AND ADJUSTMENT
PROCEDURE FOR STEWART ENGINEERING COMPANY TUBES SUPPLIED BY
HEWLETT-PACKARD COMPANY**

CONDITIONS OF WARRANTY

A backward wave oscillator tube manufactured by Stewart Engineering Company, Soquel, California, is warranted by the manufacturer to be free of defects in material and workmanship for 18 months from the date of purchase from , or 500 hours filament life, whichever occurs first. Allowances for premature failure within 6 months from the date of shipment from  will be pro-rated on the basis of remaining guaranteed filament life. Following the 6 month period, allowance for premature failure will be pro-rated on the basis of remaining guaranteed filament life, or on the basis of months remaining in this 12 month period, whichever is the lesser credit.

The Hewlett-Packard Company will process warranty claims for  customers on Stewart backward wave oscillator tubes which were supplied by  as original equipment or replacements for  instruments. All allowances by the manufacturer will be passed on to the customer.

After expiration of this warranty, all replacement backward wave oscillator tubes should be obtained directly from Stewart Engineering Company, Soquel, California.

A Stewart backward wave oscillator tube returnable to the Hewlett-Packard Company under the conditions of this warranty must be packed and shipped according to instructions below, and must be accompanied by the Warranty Claim on the reverse side of this form. Any chronistor included in the instrument, must also be returned with the Warranty Claim. Please follow shipping instructions carefully to assure safe arrival of the backward wave oscillator tube since no allowance can be made on broken tubes.

SHIPPING INSTRUCTIONS

- 1) Carefully wrap the backward wave oscillator tube in 1/4 inch thick "kimpack", cotton batting, or other soft padding material.
- 2) Wrap the above in heavy kraft paper.
- 3) Pack in a rigid container which is at least 4 inches larger than the tube in each direction.
- 4) Surround the tube with at least 4 inches of packed excelsior or similar shock absorbing material. Be certain that the packing is tight all around the tube.
- 5) Tubes returned from outside the continental United States should be packed in a wooden box.
- 6) Mark container FRAGILE and ship prepaid via Air Freight or Railway Express. Do not ship via Parcel Post or Air Parcel Post since experience has shown that fragile items are more apt to be damaged when shipped by these means.

3/9/59

BACKWARD WAVE OSCILLATOR TUBE WARRANTY CLAIM

IMPORTANT: -- To expedite your claim, please answer all questions fully since a claim cannot be processed without adequate information.

FROM: _____ DATE: _____
NAME _____
COMPANY _____
ADDRESS _____

If instrument contains a
chronistor please remove
and attach below

Person to contact for further information:
NAME _____
TITLE _____
COMPANY _____
ADDRESS _____

Check if instrument does
not contain chronistor

Tube type _____ Serial No. _____
Tube used in  Model _____ Serial No. _____
Tube is: Original _____ Replacement _____ Date tube received _____
Date tube placed in service _____ Date of tube failure _____
Your Purchase Order No. _____ Purchased from _____
Hours service per day (average) _____ No. of days in service _____
Total filament operation _____ hours

SYMPTOMS: (Please describe nature of trouble) _____

OPERATING CONDITIONS: (Please describe conditions prior to and at time of failure)

SIGNATURE _____

IF TUBE WAS NOT OBTAINED FROM HEWLETT-PACKARD COMPANY, PLEASE RETURN
TUBE AND COMPLETED FORM TO WHEREVER TUBE WAS PURCHASED.



WARRANTY

All our products are warranted against defects in materials and workmanship for one year from the date of shipment. Our obligation is limited to repairing or replacing products (except tubes) which prove to be defective during the warranty period. We are not liable for consequential damages.

For assistance of any kind, including help with instruments under warranty, contact your authorized  Sales Representative for instructions. Give full details of the difficulty and include the instrument model and serial numbers. Service data or shipping instructions will be promptly sent to you. There will be no charge for repair of instruments under warranty, *except transportation charges*. Estimates of charges for non-warranty or other service work will always be supplied, if requested, before work begins.

CLAIM FOR DAMAGE IN SHIPMENT

Your instrument should be inspected and tested as soon as it is received. The instrument is insured for safe delivery. If the instrument is damaged in any way or fails to operate properly, file a claim with the carrier or, if insured separately, with the insurance company.

SHIPPING

On receipt of shipping instructions, forward the instrument prepaid to the destination indicated. You may use the original shipping carton or any strong container. Wrap the instrument in heavy paper or a plastic bag and surround it with three or four inches of shock-absorbing material to cushion it firmly and prevent movement inside the container.

GENERAL

Your authorized  Sales Representative is ready to assist you in any situation, and you are always welcome to get directly in touch with Hewlett-Packard service departments:

CUSTOMER SERVICE

Hewlett-Packard Company
395 Page Mill Road
Palo Alto, California, U.S.A.
Telephone: DAVenport 6-1755
Direct Dial Area Code 415
TWX No. PAL AL 117-U
Cable: "HEWPACK"

OR (In Western Europe)

Hewlett-Packard S.A.
Rue du Vieux Billard No. 1
Geneva, Switzerland
Telephone: (022) 26. 43. 36
Cable: "HEWPACKSA"





MANUAL CHANGES

MODEL 686C

SWEEP OSCILLATOR

Manual Serial Prefixed: 110-
Manual Printed: 6/61

To adapt this manual to instruments with other serial prefixes check for errata below, and make changes shown in tables.

Instrument Serial Prefix	Make Manual Changes	Instrument Serial Prefix	Make Manual Changes
110-	ERRATA		
152-	1, ERRATA		
225-	1, 2, ERRATA		

ERRATA:

Figure 2-1,

Step 12: Change 5.0 ma to 3 ma.

Step 14: Change 1.0 ma to 2 ma.

Paragraph 2-3,

Step 14: Change to read: "The anode current will read about 0.5 ma and should not exceed 2 ma.

Step 16: Delete the sentence: "The collector current should read 2 to 3 ma."

Paragraph 4-2 (General Precautions),

Add the following: "CAUTION: Thermistor R43 is fragile. Handle with care. Do not use excessive pressure on thermistor body or its leads. Excessive pressure will destroy the thermistor."

A new warranty claim form is attached to this manual change sheet. Use the attached form instead of the tube warranty claim form in the Operating and Service Manual.

Under Specifications,

Change POWER VARIATION to read: "With leveler operating: less than +1.25 db over entire frequency range."

Paragraph 4-16B,

Delete Step 1)j(2).

Figure 4-22,

Delete C108.

Table 5-1,

Delete C108.

CR102 through CR106, CR302, CR303: Change to diode, silicon; $\text{\textcircled{P}}$ Stock No. 1901-0029; Mfr. 02735.

CR201, 202, 203: Change to diode, silicon; $\text{\textcircled{P}}$ Stock No. 1901-0025; Mfr. 07933.

R122, 150, 151, 154: Change to resistor, fixed, deposited carbon, 525K ohms +1%, 1/2W; $\text{\textcircled{P}}$ Stock No. 0727-0377; Mfr. 19701.

Instrument Serial Prefix Make Manual Changes Instrument Serial Prefix Make Manual Changes

110-	ERRATA		
152-	1, ERRATA		
225-	1, 2, ERRATA		

CHANGE 1

Table 5-1,

R22 and 24: Change to resistor, fixed, composition, 560K ohms $\pm 10\%$, 1/2W; $\text{\textcircled{P}}$ Stock No. 0687-5641; Mfr. 01121.

R23: Change to resistor, fixed, composition, 120K ohms $\pm 10\%$, 1/2W; $\text{\textcircled{P}}$ Stock No. 0687-1241; Mfr. 01121.

V6 through V11: Change $\text{\textcircled{P}}$ Stock No. from G-84B to G-84D.

V110: Change $\text{\textcircled{P}}$ Stock No. from G-84E to G-84D.

V209 through V211: Change $\text{\textcircled{P}}$ Stock No. to G-84D.

CHANGE 2

CR301: Change to diode, silicon; $\text{\textcircled{P}}$ Stock No. 1902-0038.

CR304: Change to diode, silicon, $\text{\textcircled{P}}$ Stock No. 1901-0025.

R39: Change to resistor, fixed, wirewound, 14 ohms $\pm 10\%$, 10W; $\text{\textcircled{P}}$ Stock No. 0816-0019.

R101: Change to resistor, fixed, wirewound, 5000 ohms $\pm 10\%$, 10W; $\text{\textcircled{P}}$ Stock No. 0816-0006.

R106 through R110: Delete

R152, 153: Delete

Add R155: Resistor, fixed, composition, 100 ohms $\pm 10\%$, 1W; $\text{\textcircled{P}}$ Stock No. 0690-1011

Add R156, 157: Resistor, fixed, composition, 1000 ohms $\pm 10\%$, 1/2W; $\text{\textcircled{P}}$ Stock No. 0687-1021.

Add R172: Resistor, fixed, composition, 33K ohms $\pm 10\%$, 1/2W; $\text{\textcircled{P}}$ Stock No. 0687-3331. Optimum value selected at factory. Average value shown.

V101, 102: Change to tube, electron: type 8068; $\text{\textcircled{P}}$ Stock No. 1923-0048.

Tube socket for V102: Change $\text{\textcircled{P}}$ Stock No. to 1200-0020.

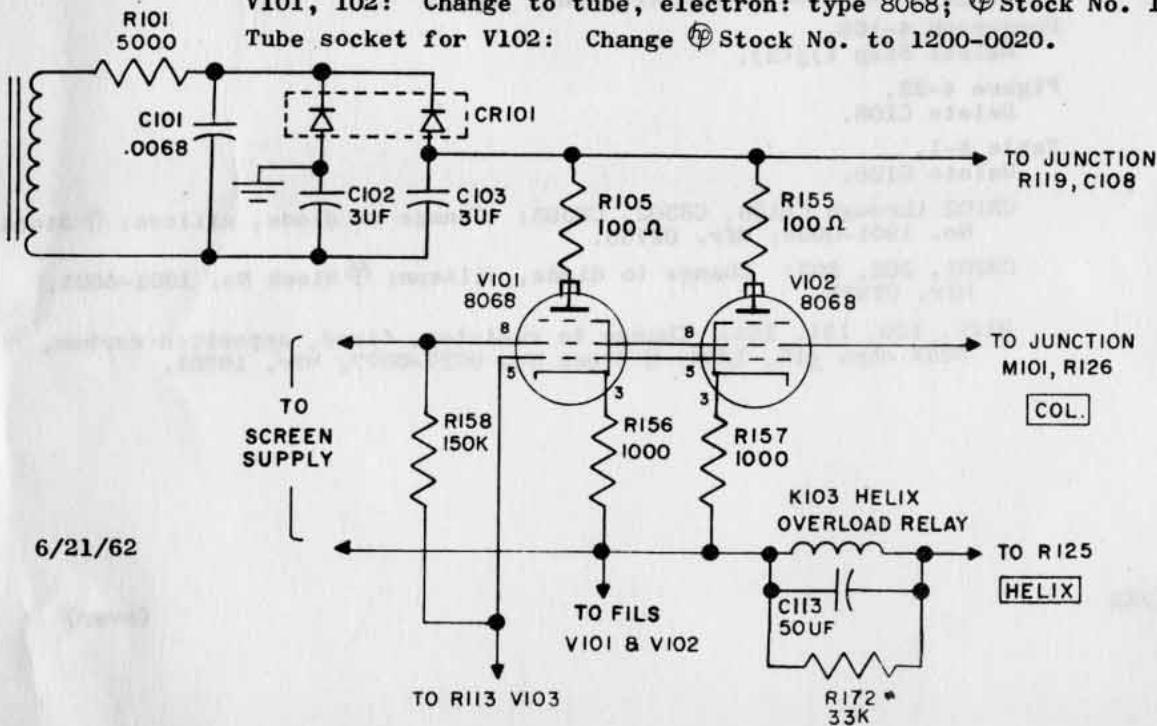

6/21/62

hp MANUAL CHANGES

MODEL 686C

SWEEP OSCILLATOR

Manual Serial Prefixed: 110-
Manual Printed: 6/61

To adapt this manual to instruments with other serial prefixes check for errata below, and make changes shown in tables.

Instrument Serial Prefix	Make Manual Changes	Instrument Serial Prefix	Make Manual Changes
110-	ERRATA		
152-	1, ERRATA		
225-	1, 2, ERRATA		
233-	1, 2, 3, ERRATA		

ERRATA:

Figure 2-1,

Step 12: Change 5.0 ma to 3 ma.

Step 14: Change 1.0 ma to 2 ma.

Paragraph 2-3,

Step 14: Change to read: "The anode current will read about 0.5 ma and should not exceed 2 ma."

Step 16: Delete the sentence: "The collector current should read 2 to 3 ma."

Paragraph 4-2 (General Precautions),

Add the following: "CAUTION: Thermistor R43 is fragile. Handle with care. Do not use excessive pressure on thermistor body or its leads. Excessive pressure will destroy the thermistor."

A new warranty claim form is attached to this manual change sheet. Use the attached form instead of the tube warranty claim form in the Operating and Service Manual.

Under Specifications,

Change POWER VARIATION to read: "With leveler operating: less than ± 1.25 db over entire frequency range."

Paragraph 4-16B,

Delete Step 1)j(2).

Figure 4-22,

Delete C108.

Table 5-1,

Delete C108.

CR102 through CR106, CR302, CR303: Change to diode, silicon; $\text{\textcircled{P}}$ Stock No. 1901-0029; Mfr. 02735.

CR201, 202, 203: Change to diode, silicon; $\text{\textcircled{P}}$ Stock No. 1901-0025; Mfr. 07933.

R122, 150, 151, 154: Change to resistor, fixed, deposited carbon, 525K ohms $\pm 1\%$, 1/2W; $\text{\textcircled{P}}$ Stock No. 0727-0377; Mfr. 19701.

9/10/62

8/29/62

6/21/62

(over)

Instrument Serial Prefix

Make Manual Changes

Instrument Serial Prefix

Make Manual Changes

110-	ERRATA
152-	1, ERRATA
225-	1, 2, ERRATA
233-	1, 2, 3, ERRATA

CHANGE 1

Table 5-1,

- R22 and 24: Change to resistor, fixed, composition, 560K ohms $\pm 10\%$, 1/2W; $\text{\textcircled{P}}$ Stock No. 0687-5641; Mfr. 01121.
- R23: Change to resistor, fixed, composition, 120K ohms $\pm 10\%$, 1/2W; $\text{\textcircled{P}}$ Stock No. 0687-1241; Mfr. 01121.
- V6 through V11: Change $\text{\textcircled{P}}$ Stock No. from G-84B to G-84D.
- V110: Change $\text{\textcircled{P}}$ Stock No. from G-84E to G-84D.
- V209 through V211: Change $\text{\textcircled{P}}$ Stock No. to G-84D.

CHANGE 2

- CR301: Change to diode, silicon; $\text{\textcircled{P}}$ Stock No. 1902-0038.
- CR304: Change to diode, silicon, $\text{\textcircled{P}}$ Stock No. 1901-0025.
- R39: Change to resistor, fixed, wirewound, 14 ohms $\pm 10\%$, 10W; $\text{\textcircled{P}}$ Stock No. 0816-0019.
- R101: Change to resistor, fixed, wirewound, 5000 ohms $\pm 10\%$, 10W; $\text{\textcircled{P}}$ Stock No. 0816-0006.
- R106 through R110: Delete
- R152, 153: Delete
- Add R155: Resistor, fixed, composition, 100 ohms $\pm 10\%$, 1W; $\text{\textcircled{P}}$ Stock No. 0690-1011
- Add R156, 157: Resistor, fixed, composition, 1000 ohms $\pm 10\%$, 1/2W; $\text{\textcircled{P}}$ Stock No. 0687-1021.
- Add R172: Resistor, fixed, composition, 33K ohms $\pm 10\%$, 1/2W; $\text{\textcircled{P}}$ Stock No. 0687-3331. Optimum value selected at factory. Average value shown.
- V101, 102: Change to tube, electron: type 8068; $\text{\textcircled{P}}$ Stock No. 1923-0048.
- Tube socket for V102: Change $\text{\textcircled{P}}$ Stock No. to 1200-0020.

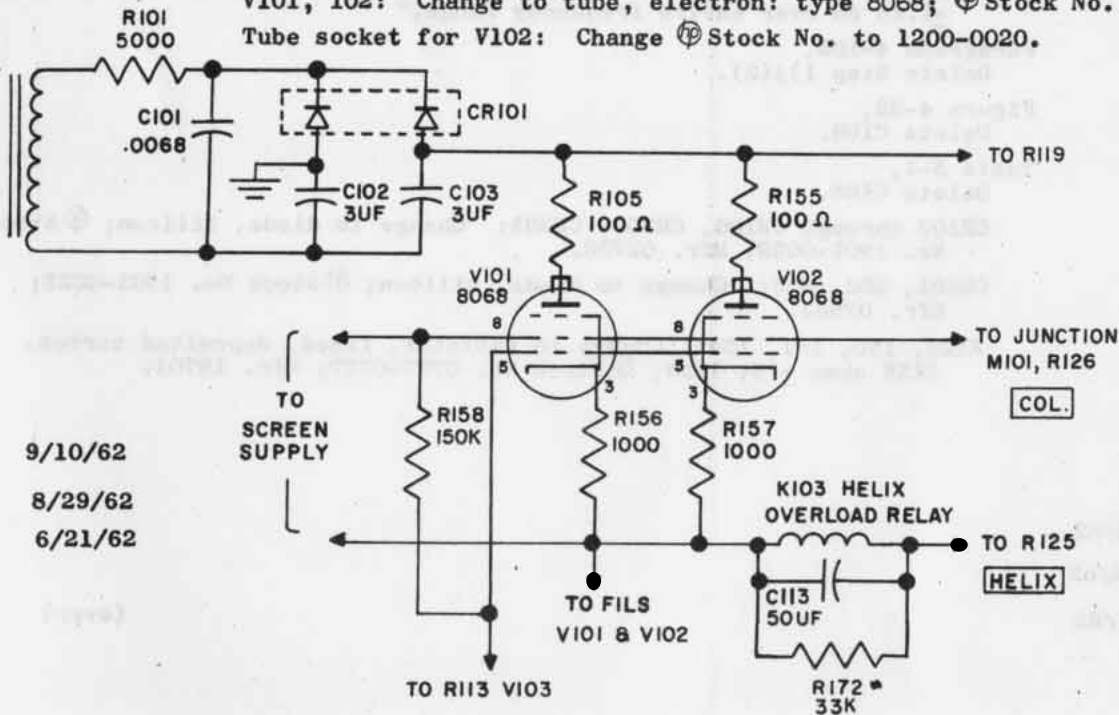

9/10/62
8/29/62
6/21/62

Instrument Serial Prefix	Make Manual Changes	Instrument Serial Prefix	Make Manual Changes
110-	ERRATA		
152-	1, ERRATA		
225-	1, 2, ERRATA		
233-	1, 2, 3, ERRATA		

CHANGE 3

Figure 4-24, Amplitude Modulator and Reference Anode Circuit,
Change schematic diagram as shown in partial schematic below.

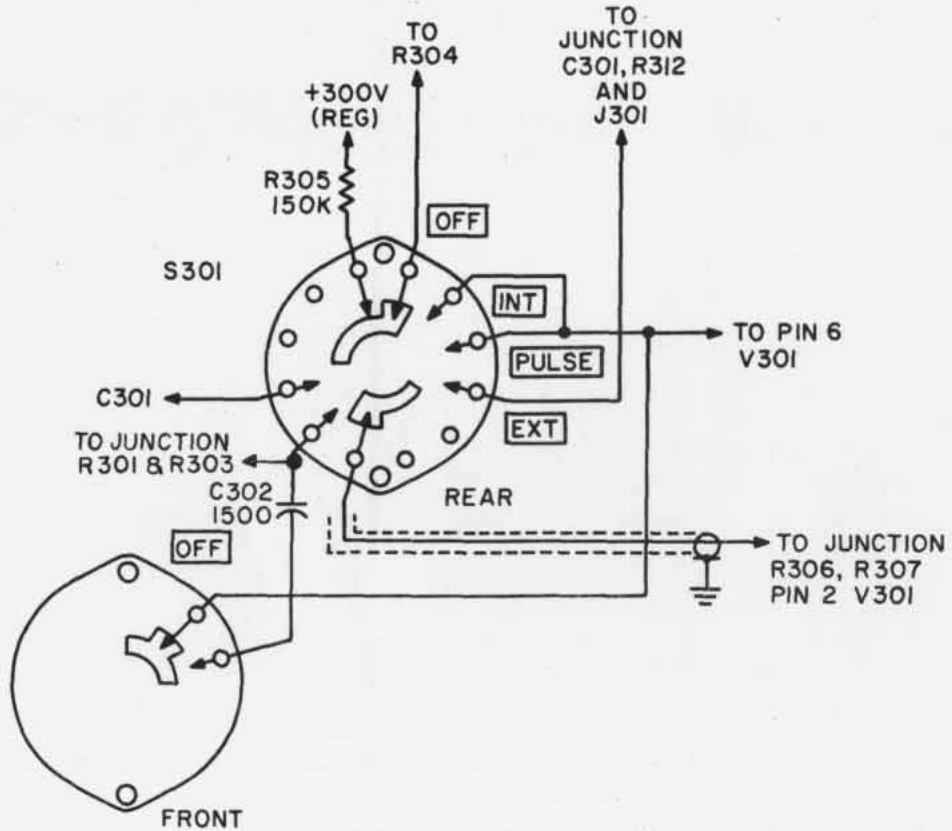

9/10/62

8/29/62

hp MANUAL CHANGES

MODEL 686C

SWEEP OSCILLATOR

Manual Serial Prefixed: 110-
Manual Printed: 6/61

To adapt this manual to instruments with other serial prefixes check for errata below, and make changes shown in tables.

Instrument Serial Prefix	Make Manual Changes	Instrument Serial Prefix	Make Manual Changes
110-	ERRATA	301-	1, 2, 3, 4, ERRATA
152-	1, ERRATA		
225-	1, 2, ERRATA		
233-	1, 2, 3, ERRATA		

ERRATA:

Figure 2-1,

Step 12: Change 5.0 ma to 3 ma.

Step 14: Change 1.0 ma to 2 ma.

Paragraph 2-3,

Step 14: Change to read: "The anode current will read about 0.5 ma and should not exceed 2 ma.

Step 16: Delete the sentence: "The collector current should read 2 to 3 ma."

Paragraph 4-2 (General Precautions),

Add the following: "CAUTION: Thermistor R43 is fragile. Handle with care. Do not use excessive pressure on thermistor body or its leads. Excessive pressure will destroy the thermistor."

A new warranty claim form is attached to this manual change sheet. Use the attached form instead of the tube warranty claim form in the Operating and Service Manual.

Under Specifications,

Change POWER VARIATION to read: "With leveler operating: less than +1.25 db over entire frequency range."

Paragraph 4-16B,

Delete Step 1)j(2).

Figure 4-22,

Delete C108.

Table 5-1,

Delete C108.

CR102 through CR106, CR302, CR303: Change to diode, silicon; $\text{\textcircled{C}}$ Stock No. 1901-0029; Mfr. 02735.

CR201, 202, 203: Change to diode, silicon; $\text{\textcircled{C}}$ Stock No. 1901-0025; Mfr. 07933.

R122, 150, 151, 154: Change to resistor, fixed, deposited carbon, 525K ohms +1%, 1/2W; $\text{\textcircled{C}}$ Stock No. 0727-0377; Mfr. 19701.

Table of Replaceable Parts,

J201, 202, 203, 301: Change $\text{\textcircled{C}}$ Stock No. to 1250-0018.

1/14/63

(over)

Supplement A for
686C-900

Instrument Serial Prefix Make Manual Changes Instrument Serial Prefix Make Manual Changes

110-	ERRATA	301-	1, 2, 3, 4, ERRATA
152-	1, ERRATA		
225-	1, 2, ERRATA		
233-	1, 2, 3, ERRATA		

CHANGE 1

Table 5-1,

R22 and 24: Change to resistor, fixed, composition, 560K ohms $\pm 10\%$, 1/2W; $\text{\textcircled{C}}$ Stock No. 0687-5641; Mfr. 01121.

R23: Change to resistor, fixed, composition, 120K ohms $\pm 10\%$, 1/2W; $\text{\textcircled{C}}$ Stock No. 0687-1241; Mfr. 01121.

V6 through V11: Change $\text{\textcircled{C}}$ Stock No. from G-84B to G-84D.

V110: Change $\text{\textcircled{C}}$ Stock No. from G-84E to G-84D.

V209 through V211: Change $\text{\textcircled{C}}$ Stock No. to G-84D.

CHANGE 2

CR301: Change to diode, silicon; $\text{\textcircled{C}}$ Stock No. 1902-0038.

CR304: Change to diode, silicon, $\text{\textcircled{C}}$ Stock No. 1901-0025.

R39: Change to resistor, fixed, wirewound, 14 ohms $\pm 10\%$, 10W; $\text{\textcircled{C}}$ Stock No. 0816-0019.

R101: Change to resistor, fixed, wirewound, 5000 ohms $\pm 10\%$, 10W; $\text{\textcircled{C}}$ Stock No. 0816-0006.

R106 through R110: Delete

R152, 153: Delete

Add R155: Resistor, fixed, composition, 100 ohms $\pm 10\%$, 1W; $\text{\textcircled{C}}$ Stock No. 0690-1011

Add R156, 157: Resistor, fixed, composition, 1000 ohms $\pm 10\%$, 1/2W; $\text{\textcircled{C}}$ Stock No. 0687-1021.

Add R172: Resistor, fixed, composition, 33K ohms $\pm 10\%$, 1/2W; $\text{\textcircled{C}}$ Stock No. 0687-3331. Optimum value selected at factory. Average value shown.

V101, 102: Change to tube, electron: type 8068; $\text{\textcircled{C}}$ Stock No. 1923-0048.

Tube socket for V102: Change $\text{\textcircled{C}}$ Stock No. to 1200-0020.

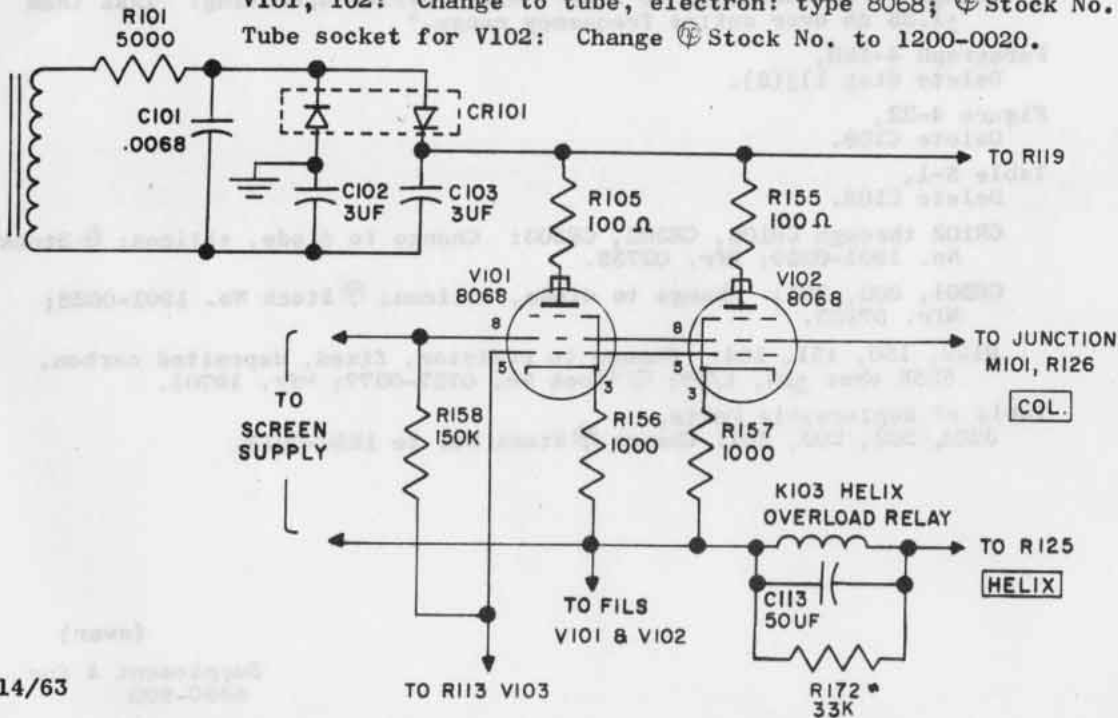

Instrument Serial Prefix

Make Manual Changes

Instrument Serial Prefix

Make Manual Changes

110-	ERRATA
152-	1, ERRATA
225-	1, 2, ERRATA
233-	1, 2, 3, ERRATA

301-	1, 2, 3, 4, ERRATA

CHANGE 3

Figure 4-24, Amplitude Modulator and Reference Anode Circuit, Change schematic diagram as shown in partial schematic below.

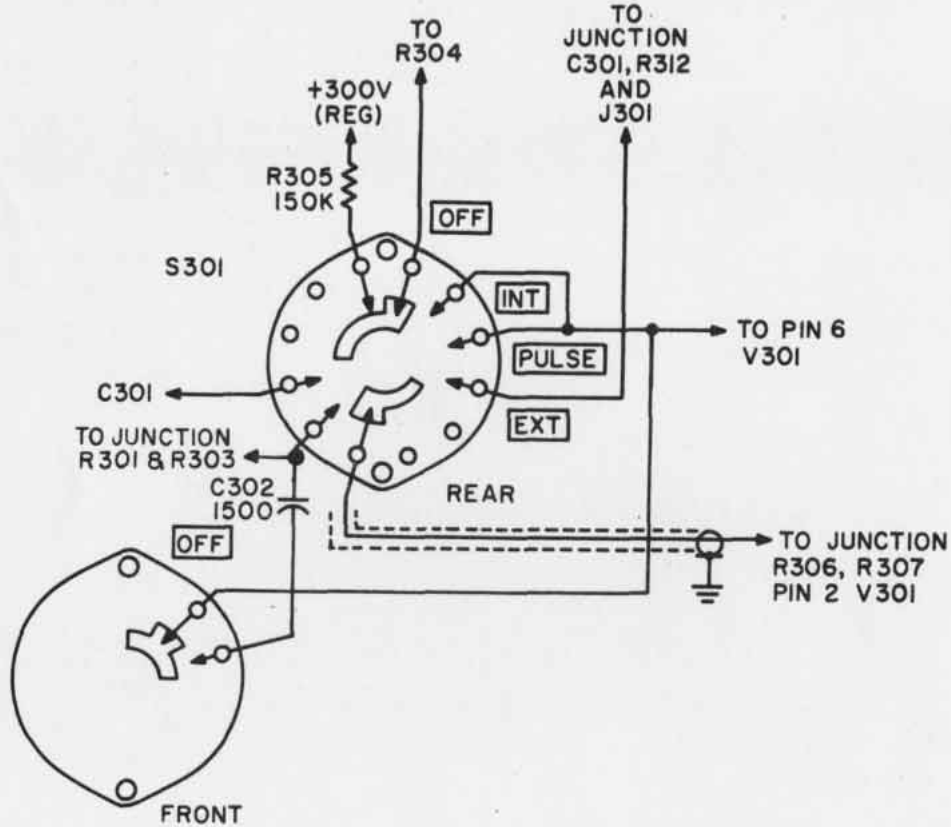

CHANGE 4

In the schematic diagram of Figure 4-20, 4-22 and 4-26 and the Table of Replaceable Parts,

- C116: Change to 470 pf; Ⓢ Stock No. 0140-0027.
- C117: Change to 170-780 pf; Ⓢ Stock No. 0131-0003.
- C206: Change to 18 pf; Ⓢ Stock No. 0140-0144.
- R32: Change to 15 ohm; Ⓢ Stock No. 0812-0035.

LONG TERM STABILITY CHECK - UNREGULATED LINE
682A SERIAL 001-00054
WITH 1 HR. WARMUP FREQ DRIFT 45MC IN 7 1/2 HR PERIOD
RESIDUAL FM APPROX 50 KC

